

PECO

NEWS

SPRING REPORT 2019



Always moving forward

**BRITISH INNOVATION
GLOBAL REPUTATION**



ALWAYS MOVING FORWARD!

Here we are again! One year rolls on into another! There is no doubt that after a relatively quiet beginning to 2018 by the end of the year the market was very busy, and looks set to continue if current trends are any indication. The model railway hobby seems to be continuing through a period of increased popularity as people look for something creative to occupy their free time. This is great news for all of us and let's hope that we can capture those opportunities!

Here at PECO we continue to invest heavily in our manufacturing facility, with the commissioning of a brand-new automated flexible track machine due to come on-line during the early part of 2019. This will help us maintain and grow our production capabilities for what is a key part of our product portfolio. As for whatever else we produce, flexible track will always remain one of our most important product lines.

Our programme this year includes a continuation of projects that have not yet been completed from 2018, such as the turntable motor, Bullhead crossings and slips, and catenary portals. But we also have some brand new and exciting announcements to make too, with the PECO Lectrics "TwistLock" turnout motor being one project that will create a great deal of interest. Further announcements for the developing PECO Streamline Bullhead OO track system are here, along with the news that we are embarking on a project to upgrade our "Quality Line" N gauge wagons, plus more OO-9 stock!



These new products, plus those that have previously been announced, will hopefully bring new opportunities for our retailers and distributors the world over, and help to attract new customers into this wonderful and absorbing pastime.

STEVE HAYNES Sales Manager, Pritchard Patent Product Co. Ltd

CONTENTS

ALL SCALES

2. PECO SCENE WEATHERING KITS
STATIC GRASS SYSTEM
PHOTOGRAPHIC BACKGROUNDS
3. PECO LECTRICS

N SCALE

4. PECO N WAGONS
PECO SETRACK 2ND RADIUS STARTER SET
5. PECO SETRACK MULTI-PACKS
PECO STREAMLINE CODE 55 TURNOUTS
6. PECO STREAMLINE CODE 75 BULLHEAD
7. PECO HO CODE 70
PECO LINESIDE OO CATENARY PORTALS

OO/HO SCALE

8. PARKSIDE WAGON KIT
RATIO, WILLS AND WILLS MODERN
9. MODELSCENE

OO-9 SCALE

10. GREAT LITTLE TRAINS
PECO SETRACK 1ST RADIUS STARTER SET

O SCALE

11. PECO LINESIDE AND PARKSIDE WAGON KIT
12. PECO PUBLICATIONS AND PECORAMA

ALL SCALES



PECO SCENE

**NEW
ANNOUNCEMENT**

PS-370/PS-371 PECO Scene Trackbed Weathering Kits

for both Steam and Diesel eras



PSG-13

Layering Spray Adhesive

Pump action glue
for Static Grass



**DELIVERED
2018**

PSG-3 Static Grass Precision Applicator

PSG-2 Static Grass Pro Applicator

Photographic Scenic Backgrounds

A new line of photographic backscenes. Three sheets are supplied that can be used individually or joined seamlessly together. Each sheet: 800mm x 320mm.



**DELIVERED
2018**

SKP-01 PECO Scene Photographic Background, River Valley (3 sheets)

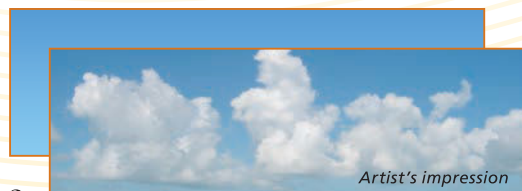

**NEW
ANNOUNCEMENT**

SKP-02 PECO Scene Photographic Background, Plain Sky

SKP-03 PECO Scene Photographic Background, Sky & Clouds

Artist's impression

TWISTLOCK

The new PECO Lectrics Twistlock Turnout Motor combines sound and reliable technology with an innovative new way of installation. We believe that this will be the easiest turnout motor installation you'll ever find!

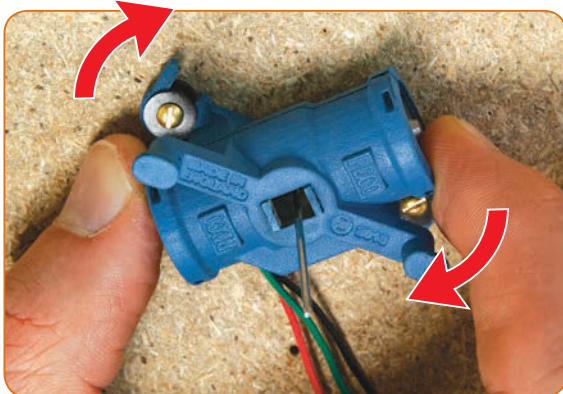

An old friend. Just a new twist!



Pre-production rendering

PL-1000 PECO Lectrics TwistLock Turnout Motor

PL-1001 PECO Lectrics TwistLock Turnout Motor and Microswitch

PL-1005 PECO Lectrics TwistLock Turnout Microswitch

PL-1006 PECO Lectrics TwistLock Turnout Motor Surface Mount

- **Powerful** – 16vAC solenoid turnout motor, 3 amps
- **Compatible** – with all PECO (and other manufacturers') turnouts up to O gauge.
- **Over and over again** – Can be removed and re-fitted repeatedly and still be in perfect alignment each time!
- **Neat and tidy** – no need to cut large rectangular holes in the baseboard.
- **Invisible** – virtually invisible on the surface.
- **Easier for access** – no need to work upside down in the darkness under the layout.
- **No soldering** – pre-wired.
- **Long reach** – drive pin long enough to reach through baseboards up to 15mm thick.
- **Switch polarity the easy way** – twin microswitch attachment twist-locks to the motor – supplied separately (PL-1005) or included with PL-1001.
- **On top** – surface mounting option also available – special mount available (PL-1006).

IN PROGRESS

Modified specification

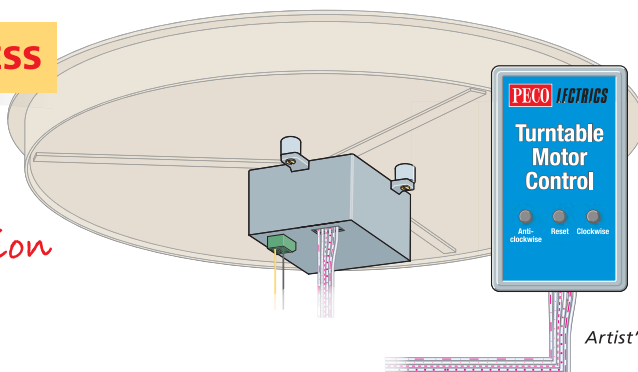

Artist's impression

PL-55 Turntable Motor

- Compatible with all PECO turntable kits
- Can be retro-fitted to installed turntables
- DC operation
- 12vDC motor, non-indexing
- Simple push-button control: press and hold, and release to move deck to desired track.

PECO QUALITY LINE WAGONS

Re-tooling project for our PECO N Gauge 'Quality Line' 5 and 7 Plank Ready to Run Wagons.



Pre-production rendering

Key features

- More end variations
- NEM coupling pockets
- Metal wheels
- 9ft wheelbase

NEW ANNOUNCEMENT

DELIVERED 2018



NR-10B

BR/SR 'Hybar' Open Ferry Wagon

Featuring an adjustable bar that, on the prototype, would be used to support a tarpaulin. On our model the bar is included, and can be removed as required.

NEW ANNOUNCEMENT

NR-121D

Easy Assembly Chassis Kit

10ft Wheelbase,
Steel Solebars,
Disc Wheels



PECO SETRACK

ST-301

PECO Setrack Starter Set 2nd Radius

Contents:

- 4 x ST-1 Standard Straight
- 4 x ST-11 Double Straight
- 8 x ST-15 No. 2 Rad. Dble. Curve
- 1 x ST-10 Standard Straight (wired)
- 2 x ST-5 Right Hand Turnout
- 2 x ST-8 Buffer Stop
- 1 x IN-1 Planbook

DELIVERED 2018



PECO SETRACK

ST-3000 N Setrack Multi-pack Series



**DELIVERED
2018**

PECO STREAMLINE

**DELIVERED
2018**

SL-U395F
Code 55 Medium
Radius Turnout
Right Hand, *Unifrog*

SL-U396F
Code 55 Medium
Radius Turnout
Left Hand, *Unifrog*

Length: 137mm
Radius: 457mm
Angle: 10°

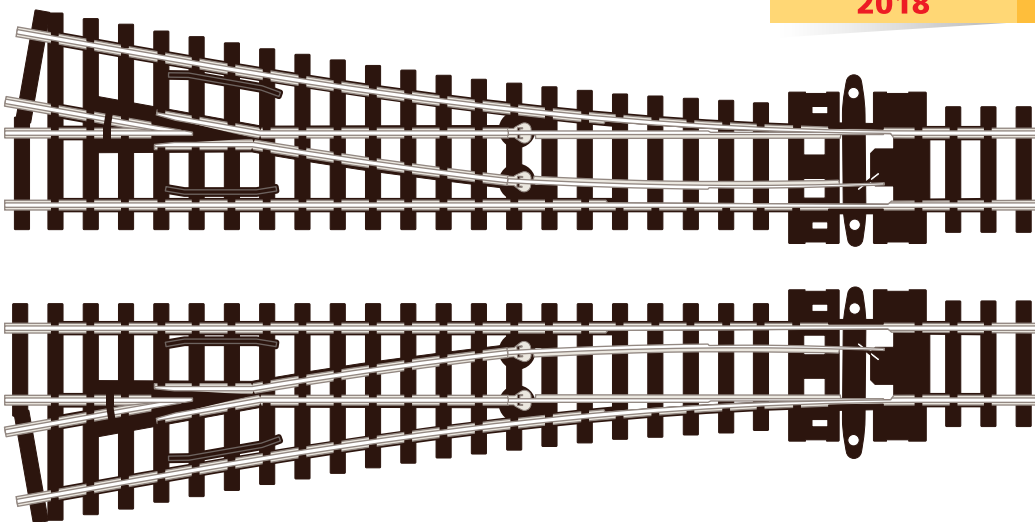

OO/HO SCALE

PECO STREAMLINE

Bullhead

Modellers will be delighted to know that we intend to expand this range substantially. The next releases will be these crossings and slips, but plans are in place to produce medium radius turnouts. Others are under consideration.

BREAKING NEWS

SL-U1195/SL-U1196 Medium Radius Turnouts now in development!

SL-1140
Rail-built Buffer Stop

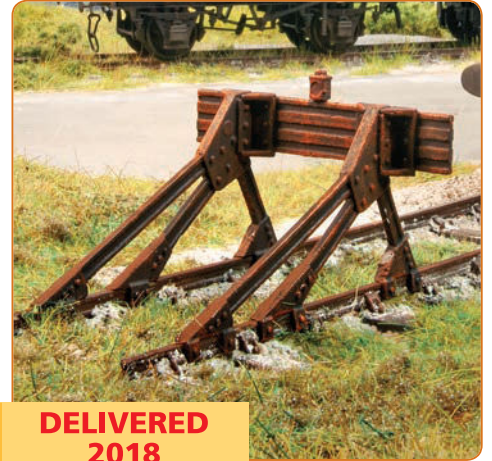

DELIVERED 2018

SL-U1190 Double Slip Unifrog

Length: 249mm Angle: 12°

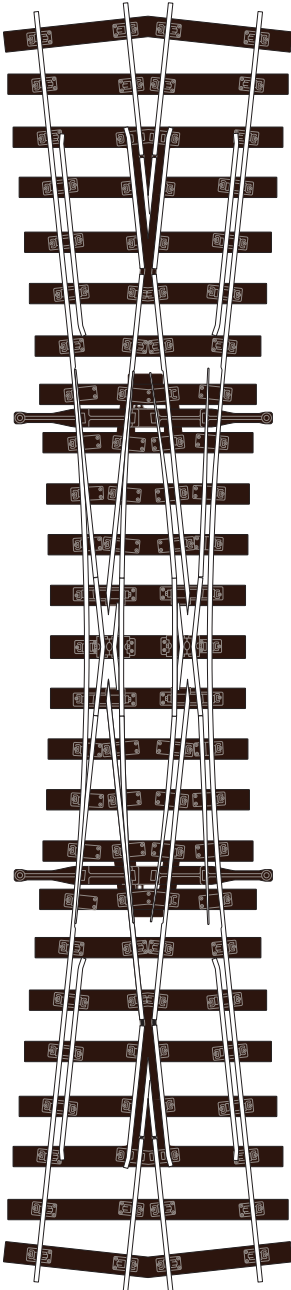

SL-U1180 Single Slip Unifrog

Length: 249mm Angle: 12°

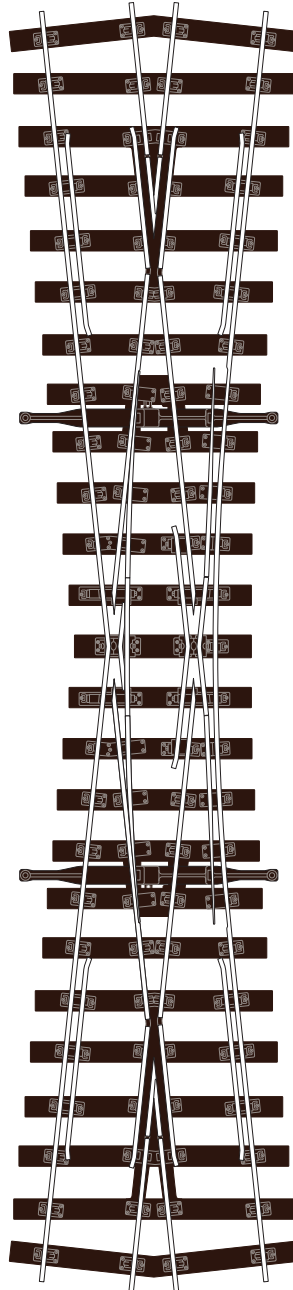

SL-U1194 Long Crossing Unifrog

Length: 249mm Angle: 12°

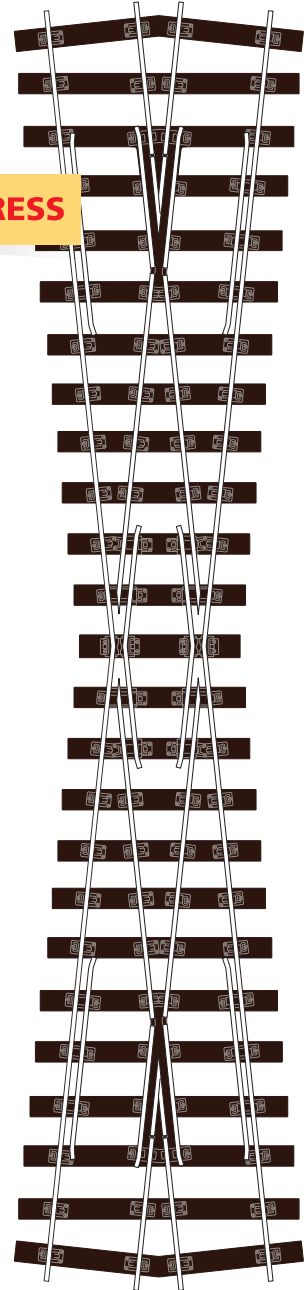

IN PROGRESS

**DELIVERED
2018**

SL-7000 **Code 70 Flexible Track**

Wooden Sleeper Type
Length: 914mm



PECO STREAMLINE

Look for the distinctive orange branding at your model shop.

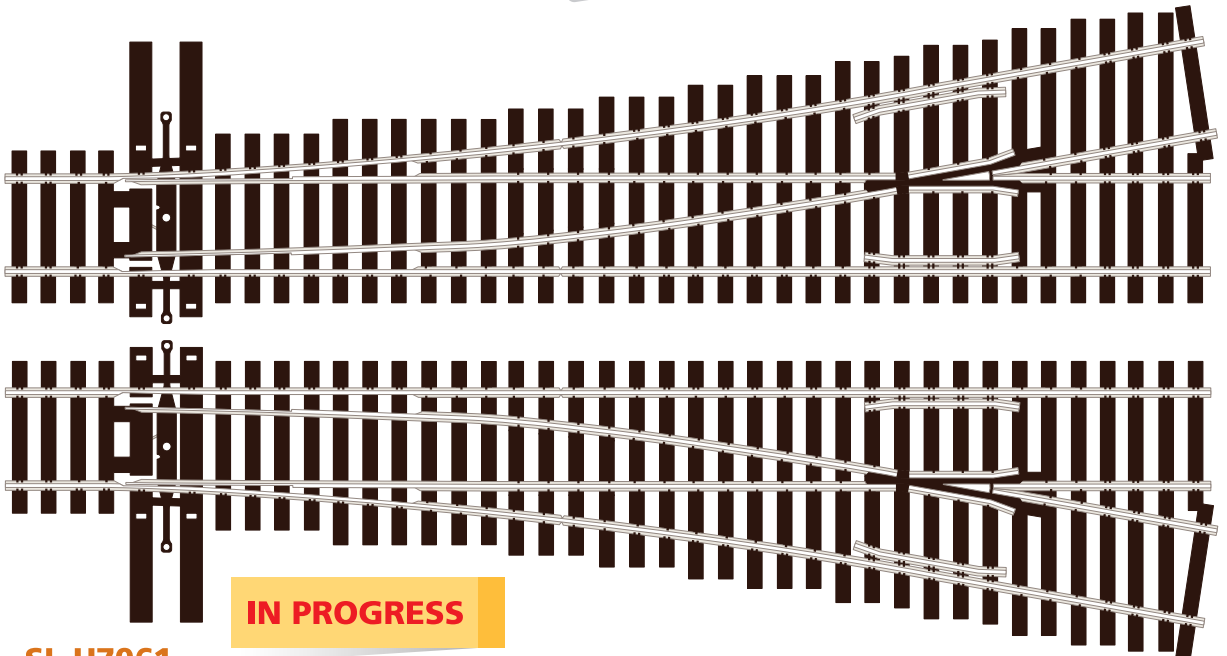

IN PROGRESS

SL-U7061
Code 70 #6 Turnout
Right Hand, **Unifrog**

SL-U7062
Code 70 #6 Turnout
Left Hand, **Unifrog**
Length: 305.7mm
Angle: 9.5°

IN PROGRESS



Pre-production model

PECO LINESIDE

LC-120
Catenary System
Two Track Portal

LC-121
Catenary System
Extension Section

We are currently working in collaboration with Sommerfeldt, Germany, on a multi-track gantry to complement our new British outline OHLE system. The design is based on a West Coast Main Line (UK) prototype.

The kit will include fine etched brass, steel and plastic parts, to create a realistic and essential addition to the range.

OO/HO SCALE



IN PROGRESS



Illustrations show 3D printed samples

PC90 13 ton Hopper Wagon Kit

The first new kit under PECO ownership! BR 13 Ton Steel Hopper Wagon, dia. 1/142 & 1/144.

- Over 2,600 built to an LNER design 1949 - 1953
- All-steel welded construction
- Used for transporting of coal and iron ore
- Phased out of service in the 1970s/80s

This kit will also be available in O scale as the PS116.

NEW ANNOUNCEMENT

PC13 LNER Bulk Grain Van

From 1929 the LNER built several of these wagons, which proved to be very versatile and successful – many survived into the 1970s. We are pleased to announce the return of this kit, missing from the range for a few years.



PC13



IN PROGRESS

Modified design



Pre-production rendering

554 Wartime (ARP) Flat Roof Signal Box

Built during WWII, these air-raid protected structures lasted in use for many decades, and some survive today.

Footprint: 100mm x 54mm incl. staircase.

NEW ANNOUNCEMENT



WILLS-MODERN SSM323 Security Gate Kit



WILLS-KITS



SS92 Garden Accessory Set

**DELIVERED
2018**

PECO **model scene**

OO Modelscene Bus Kits



5138



5139



5141



5140



5142



5143



5501



5502



5503

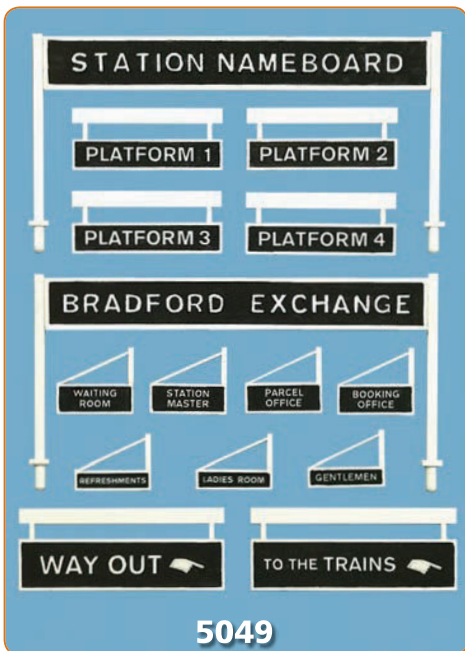

5049



5044

**DELIVERED
2018**



OO Modelscene Accessories

- 5044** Post Boxes (pictured)
- 5047** Yard Lamps
- 5048** Platform Accessories Steam Era
- 5049** Station Nameboards and Signs (pictured)
- 5050** Speed Restriction Signs
- 5053** Platform Accessories Modern Era (pictured)

OO-9 SCALE

PECO Great Little Trains

NEW ANNOUNCEMENT

Ready to run



GR-340
Snailbeach Tramway
4-wheel Hopper Wagon



GR-570
FR 4-wheel
Quarryman Coach



Pre-production renderings

GR-580
FR 4-wheel
Brake Vans

Pre-production rendering

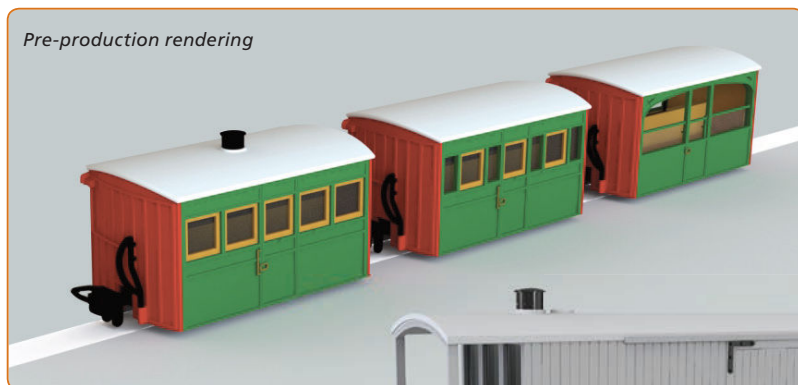

IN PROGRESS

Ffestiniog 'Bug Box' Coaches

GR-550 4-wheel Coach 1st Class

GR-555 4-wheel Coach 3rd Class

GR-560 4-wheel Observation Coach



Pre-production rendering

Lynton & Barnstaple 8 Ton
Bogie Goods Brake Van

GR-240 L&B Livery

GR-241 SR Livery

GR-500 Series Unlettered Green/Unlettered Red Livery
(6 variations for modellers who wish to run a freelance railway)

DELIVERED 2018

GR-500UG/UR
Glyn Valley Enclosed-side Coach

GR-520UG/UR
Glyn Valley Open-sided Coach

GR-530UG/UR
Glyn Valley Brake Coach (pictured)



GR-530UG



GR-530UR



PECO SETRACK

DELIVERED 2018

ST-400 PECO Setrack Starter Set 1st Radius

Contents:

6 x **ST-401** Standard Straight

2 x **ST-411** Double Straight

1 x **ST-413** Double Straight (wired)

1 x **ST-405** Right Hand Turnout

1 x **ST-406** Left Hand Turnout

5 x **ST-403** No. 1 Rad. Std. Curve

6 x **ST-12** No. 1 Rad. Dble. Curve

2 x **SL-440** Buffer Stop

A Planbook for OO-9 is also available. See the back cover.



from **PECO**

NEW ANNOUNCEMENT

LK-715 Signal Box, Brick Type Base

LK-716 Signal Box, Wooden Type Base

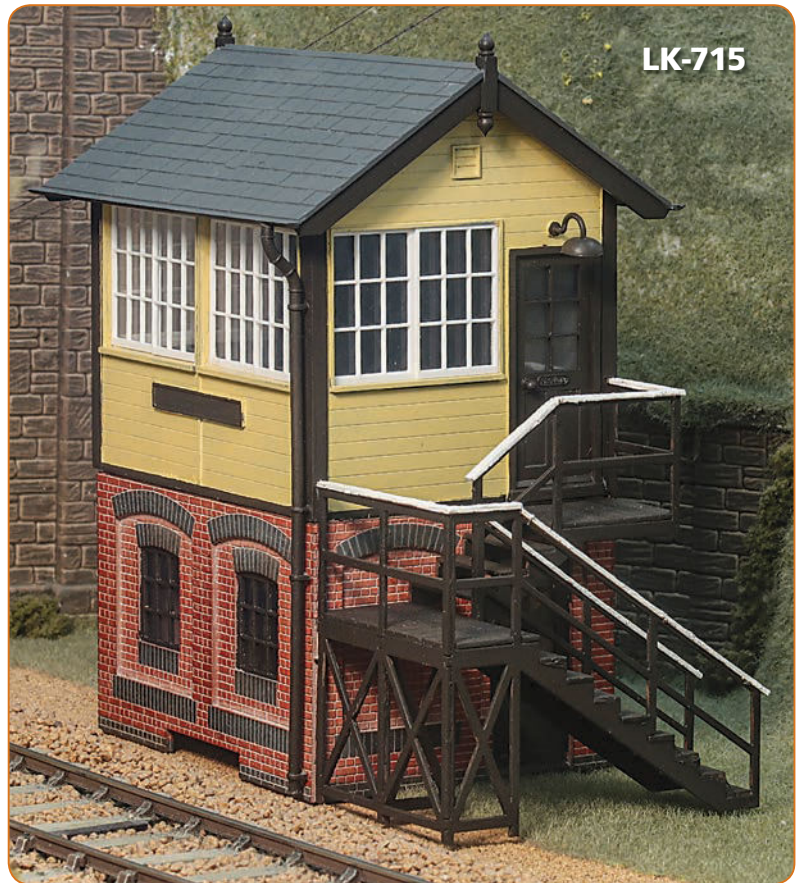

LK-715



DELIVERED 2018

LK-765 Police Telephone Box



IN PROGRESS



LK-710 Signal Box Interior

Illustrations show 3D printed samples



PS116 13 ton Hopper Wagon Kit

- Over 2,600 built to an LNER design 1949 – 1953
- All-steel welded construction
- Used for transporting of coal and iron ore
- Phased out of service in the 1970s/80s

Also in development for OO scale as the PC90.

IN PROGRESS



Illustrations show 3D printed samples



We continue to expand our range of Guides, carefully crafted to aid railway modellers of all abilities. Covering topics such as planning and design, laying trackwork, step-by-step construction tips, layout ideas and many other features, these essential companions are designed to stand ready-to-hand on the shelf of any modelling library.

Out April 2019 — **PM-210 YOUR GUIDE TO MODELLING HERITAGE RAILWAYS**



PM-400
PECO Modellers' Library
OO-9/HOe Setrack
Planbook

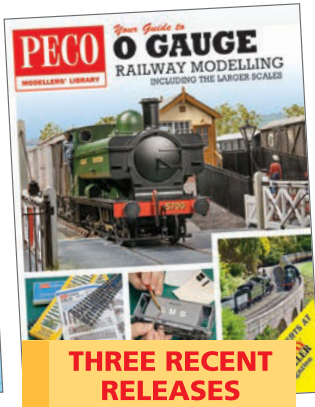

PM-208
PECO Modellers' Library
Your Guide to O Gauge
Railway Modelling



PM-209
PECO Modellers' Library
Your Guide to Modelling
Swiss Railways

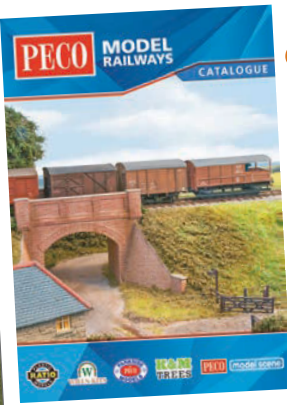

CAT-4 PECO Catalogue

Updated and expanded to include all the latest PECO product releases including Ratio, Wills, K&M Trees, Modelscene and Parkside Models.

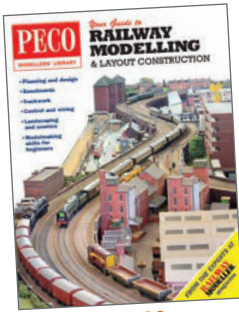

PM-200
Railway Modelling

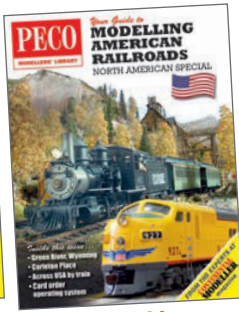

PM-201
American Railroads



PM-207
German Railways



PM-206
OO Gauge Railways

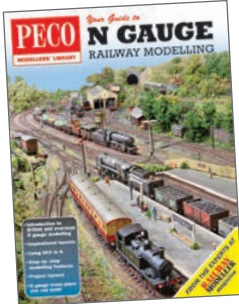

PM-204
N Gauge



PM-205
European Railways

VISIT THE HOME OF PECO

PECO stands proudly above the village of Beer, high on the hillside overlooking the sea. In fact, it is located at the Heart of Lyme Bay in the middle of the World Heritage Jurassic Coast. The 9 acre (3.5 hectares) site includes the manufacturing production unit, offices and one of South West England's best loved tourist attractions, **PECORAMA**. Our coastal location is spectacular and being a popular holiday destination there is much to see and enjoy!

The **RAILWAY MODELLER** and **CONTINENTAL MODELLER** magazines are both published by PECO. As far as we know, there is no other model railway manufacturer, publisher of model railway magazines and textbooks and tourist operator quite like PECO, for it is a business run by enthusiasts for enthusiasts and their friends. We are here as a family-run business ready to support the hobby the world over!

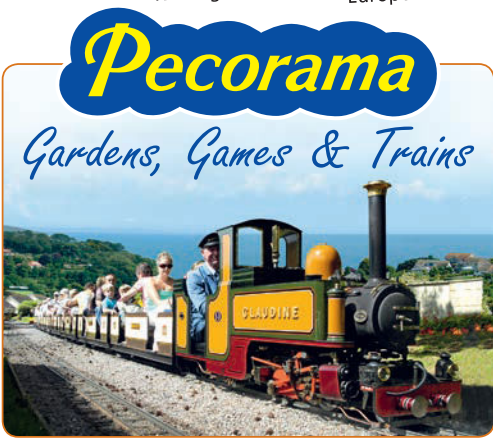

PECO THE WORLD OVER

As well as an extensive network of retailers throughout the UK, we also currently supply overseas retailers direct in these countries:

- | | | | | |
|------------------|----------------|-----------------------------------|---------------------|-----------------|
| Andorra | France | Portugal | Romania | Thailand |
| Argentina | Greece | People's Republic of China | South Africa | Ukraine |
| Austria | Hungary | Singapore | Sweden | |
| Finland | Éire | | Taiwan | |

Wholesale Distributors in Australia, Belgium, Canada, Czech Republic, Denmark, Germany, Hong Kong & People's Republic of China, India, Italy, Japan, Netherlands, New Zealand, Poland, Sweden & Norway, Russia, Spain, Switzerland, USA.

Pritchard Patent Product Co. Ltd Beer, Devon, EX12 3NA, England UK
www.peco-uk.com Tel: 01297 21542 Fax: 01297 20229 International Tel: 00 44 1297 21542 Fax: 00 44 1297 20229
 Trade Sales: sales@peco.co exports@peco.co

All information correct at the time of printing – January 2019.