



# **DCCconcepts** thinking outside the square

## **DCCconcepts Ltd - UK offices and showroom**

Unit E, The Sidings, Settle, North Yorkshire BD24 9RP, UK

Ph +44 (0) 1729 821 080 Email [salesuk@dccconcepts.com](mailto:salesuk@dccconcepts.com)

[www.dccconcepts.com](http://www.dccconcepts.com)

## **DCCconcepts Pty Ltd - AU offices and showroom**

Unit 2/3/4, 13 Lionel St., Naval Base 6165 Western Australia

Ph +61 (0) 9437 2470 Email [salesau@dccconcepts.com](mailto:salesau@dccconcepts.com)

# DCC concepts

thinking outside the square

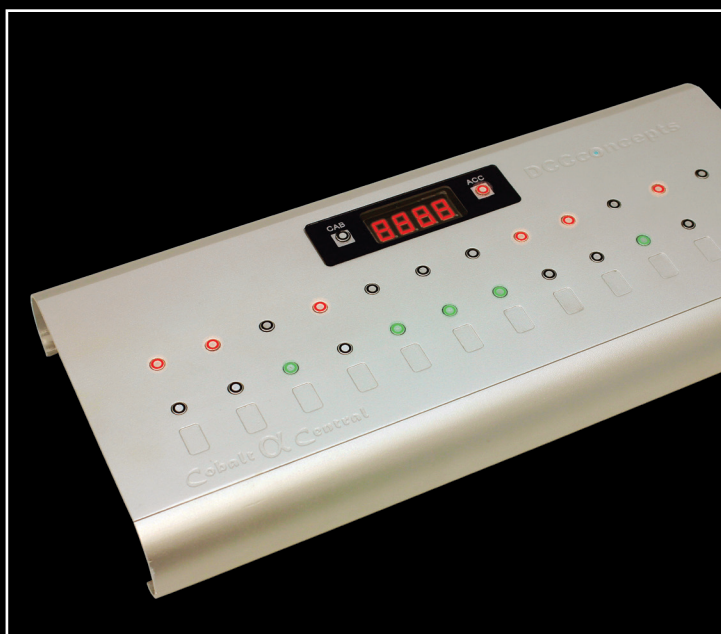
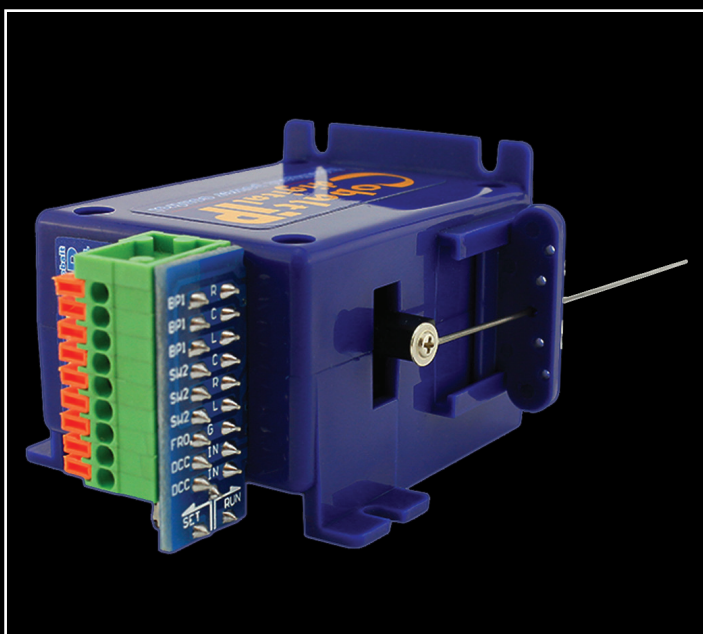

**DCC concepts ~ The layout control & creation ranges**  
**COBALT + ALPHA + Essential tools + Accessories**  
Making layout control, wiring and construction easier for ALL modellers

INTRODUCTION AND BACKGROUND	2~3
COBALT IP AND OMEGA MOTORS	4~9
COBALT IP & OMEGA APPLICATION NOTES	10~11
COBALT-SS TURNOUT MOTORS	12~15
COBALT-SS APPLICATION NOTES	16~17
COBALT-S SIGNAL BOX LEVERS	18~21
COBALT-S APPLICATION NOTES	22~23
COBALT REX AND APPLICATIONS	24~25
COBALT ACCESSORY DECODERS	26~27
COBALT ALPHA & ALPHA MIMIC	28~35
COBALT ALPHA MIMIC SIGNALS	36~37
COBALT ALPHA AND MIMIC ACCESSORIES	38~39
DCCCONCEPTS POWERBASE	40~41
COBALT CDU-2	42
LAYOUT WIRE AND WIRING ACCESSORIES	43
ESSENTIAL TOOLS AND NEEDFUL THINGS	44~45
HINTS, TIPS AND OTHER INFORMATION	46~48

PLEASE NOTE: CDU-2 AND PSU-2 ARE TRANSFORMER BASED PRODUCTS AND SO WILL NOT BE USABLE IN THE USA OR OTHER 110V AREAS OF THE WORLD.

ADDITIONALLY WHILE WE DO OUR BEST TO MAKE SURE ALL OF OUR PRODUCTS ARE WIDELY AVAILABLE, BECAUSE OF LOCAL REQUIREMENTS SOME POWERED ITEMS MAY NOT ALWAYS BE AVAILABLE IN ALL PARTS OF THE WORLD.

WE CAN ADVISE OR CONFIRM AVAILABILITY OF SPECIFIC ITEMS ON REQUEST. PLEASE EMAIL QUESTIONS TO SALESUK@DCCCONCEPTS.COM OR SALESAU@DCCCONCEPTS.COM

[www.dccconcepts.com](http://www.dccconcepts.com)

## THIS CATALOG IS ALL ABOUT PRODUCTS THAT WILL IMPROVE YOUR LAYOUT PERFORMANCE

**COBALT TURNOUT MOTORS** - WORK WITH DC OR DCC, ARE VERY EASY TO INSTALL AND CAN BE WIRED WITHOUT THE NEED FOR SOLDERING. SUPER-RELIABLE, THEY NEED ONLY SIMPLE INSTALLATION AND WIRING.

**COBALT ACCESSORY DECODERS** - USABLE WITH DC OR DCC, EASY TO WIRE, HIGH PERFORMANCE AND WITH ALL OF THE FEATURES YOU WILL NEED SO THAT THERE IS NOTHING ELSE YOU WILL NEED TO BUY.

**COBALT ALPHA PRODUCTS** - ACCEPT THE OUTPUT FROM ALMOST ANY KIND OF SWITCH YOU WISH TO USE AND TURNS ITS OUTPUTS INTO A DIGITAL COMMAND. COMBINE IT WITH ALPHASWITCH-D AND A WHOLE LAYOUT CONTROL PANEL WITH WORKING LED INDICATORS CAN BE MADE IN A QUARTER OF THE TIME - WITHOUT SOLDERING AND NEEDING ONLY ONE PLUG-IN CABLE TO CONNECT IT TO THE LAYOUT.

**ALPHA MIMIC** - LETS YOU CREATE A VERY SIMPLE "PLUG & PLAY" LED ILLUMINATED LAYOUT MIMIC OR DISPLAY PANEL THAT MIRRORS THE DIGITAL COMMANDS TO KEEP YOU INFORMED ABOUT TRACK ROUTING.

**ALPHA MIMIC GROUND SIGNALS** - ARE TOP QUALITY, SIMPLE TO INSTALL GROUND SIGNALS. READY TO GO, THEY JUST NEED TO BE PLUGGED IN! AVAILABLE IN FOUR STYLES, THE PACK INCLUDES A MIMIC CONTROL BOARD AND SO THEY ARE READY TO GO WITH NOTHING ELSE NEEDED.

**DCCCONCEPTS POWERBASE** - AT LAST, YOU CAN HAVE GRADIENTS ON YOUR LAYOUT AND STILL RUN LONG TRAINS. YOUR LOCOMOTIVES WILL ALL RUN BETTER TOO, AS POWERBASE PULLS THEM FIRMLY ONTO THE TRACK SO ELECTRICAL POWER PICKUP IS IMPROVED. A VERY SIMPLE ANSWER TO THE AGE-OLD PROBLEMS OF PULLING POWER & POWER PICKUP WITHOUT TAKING THE TOP OFF YOUR LOCOS OR HARD-TO-LEARN MODELLING SKILLS.

**COBALT CDU-2** - IMPROVING PERFORMANCE FOR USERS OF SOLENOIDS.



[www.dccconcepts.com](http://www.dccconcepts.com)

# 1 ADDITIONAL INDEX OF CATALOG DIAGRAMS AND USEFUL MODELLING ADVICE

## TIPS & WIRING DIAGRAMS WITHIN THE CATALOG

COBALT IP DIGITAL & ANALOG & OMEGA CONNECTIONS	PAGE 5
BEST APPROACH FOR WIRING ELECTROFROG/LIVE FROGS	PAGE 6
SIMPLE COBALT IP DIGITAL POWER BUS CONNECTION	PAGE 8
MORE COBALT IP DIGITAL & ANALOG & OMEGA CONNECTIONS	PAGE 10
COBALT IP AND OMEGA - CROSSOVERS AND 3-WAY POINTS	PAGE 11
COBALT-SS CONTROL BOARD CONNECTIONS	PAGE 16
COBALT-SS - CROSSOVERS AND THREE WAY POINTS	PAGE 17
COBALT-S LEVER, COBALT IP MOTORS AND SCISSORS XO	PAGE 23
COBALT REX CONNECTIONS	PAGE 24
COBALT REX CONNECTIONS & WIRING FOR DC AND DCC	PAGE 25
DCCCONCEPTS ACCESSORY DECODER CONNECTIONS	PAGE 27
COBALT ALPHA BOX CONNECTIONS (ANY SYSTEM UPGRADE)	PAGE 29
COBALT ALPHA SNIFFER - CONNECTED TO ESU ECOS & Z21	PAGE 30
THE VERSATILITY OF COBALT ALPHA & MIMIC INTERFACES	PAGE 32
ALPHA MIMIC GENERAL USAGE AND VERSATILITY	PAGE 34
POWERBASE "INSTALLATION PHOTO STORY"	PAGE 40
COBALT CDU-2 "SUPER CDU" INSTALLATION OPTIONS	PAGE 42
USING DCCCONCEPTS POWER BUS WIRING TAGS	PAGE 44
TIPS RELATING TO POINTWORK (VARIOUS)	PAGE 46
WIRING STORAGE LOOPS FOR ERROR-FREE OPERATION	PAGE 47
THINGS TO THINK ABOUT	PAGE 48

[www.dccconcepts.com](http://www.dccconcepts.com)



## OBJECTIVES:

MAKE IT DO EVERYTHING YOU WILL NEED

KEEP IT SIMPLE TO CONNECT AND USE

REDUCE THE NEED FOR LAYOUT WIRING

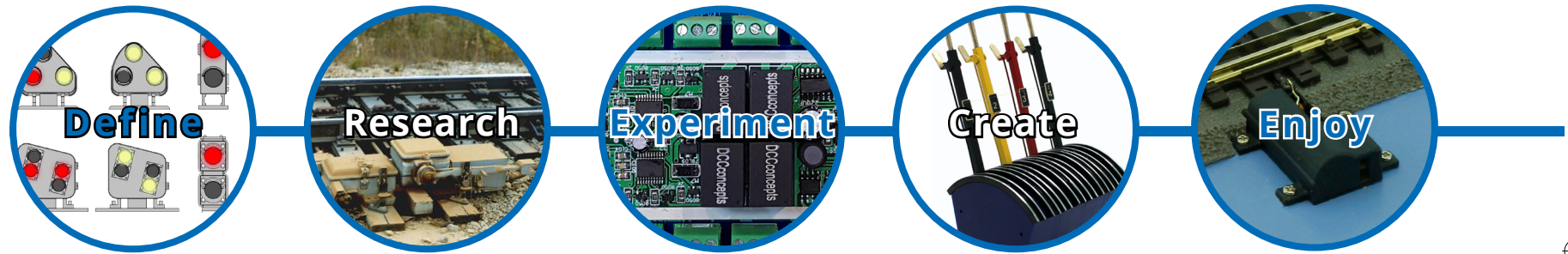

From the very beginning, the model railway hobby has had the same problems, complications and difficulties for modellers.

A very commonly seen example has been most solenoid-type point or turnout motors.

Most do not have the features that allow you to control frog power or panel lighting - and they are also very inefficient, needing big power and heavy wiring to work well.

The advent of DCC really did

not help either... as while DCC or digital control improved loco control quality it made use of accessories more complicated.

After all, who wants to have to use multiple button pushes to change points and accessories!

Clearly the creators of DCC just forgot about the pleasure of controlling a layout with the help of an easy to use Mimic Panel just like the real thing has always done.

What a shame they didn't think!

Well, all of us at DCCconcepts are modellers too, so we have decided to do our best to fix these problems once and for all. The Cobalt & Alpha ranges are the result of those efforts.

Cobalt motors need only low power to operate and are very easy to use while also having on-board switching for frog power & all other switching needs.

Our full range of Cobalt accessory decoders work with DC or DCC and have ALL the features

you could ever want plus built-in CDUs to help change inefficient solenoid motors.

Our Cobalt Alpha products let you digitally control accessories on both DC & DCC layouts. Using Alpha also reduces the need for wiring between the switches in your control panel & your layout to only ONE cable in many cases.

Even better... All Cobalt & Alpha Digital products work as well on DC as they do with DCC! Wiring is simple & connection is either

plug & Play or screw terminals. Always, any digital addressing is always a very simple to do "set the switch to learn" process.

There is a range of accessories for all of your needs or special requirements and we have lots of advice on how to use Cobalt & Cobalt Alpha on our website.

We hope you enjoy learning about our approach to making layout control easier than ever.

## OUR PRODUCT & PERFORMANCE PROMISES

We are railway modellers at heart... and we approach every item we create as if it was for ourselves. We want quality, reliability, ease of use and simple wiring so we design it in from the very beginning.

We understand that some want to stay with DC train control... while others are keen on DCC, so all of our Cobalt and Cobalt Alpha electronic items have a direct ability to work with either - DC modellers just need to add a simple to install, low cost interface so that they can use them too.

We understand that you do not want to have to keep adding cost & complication to get the job done... so we add ALL of the important features into every product - so it is ready to do it all for you.

We understand that not everyone loves wiring and soldering... so we do our best to reduce the need. Alpha & Alpha Mimic products are all "plug and play", reducing wires between control panels and layout to just ONE cable or wire pair. Cobalt motor products need far less wiring than you ever imagined!

## THE COBALT & COBALT ALPHA FAMILIES... GIVING YOU BACK THE CONTROL OF YOUR TRACKWORK

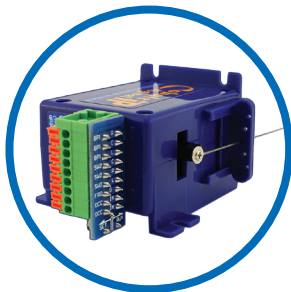

### The Cobalt iP & Omega Series "below-board" turnout motors

Cobalt is already the fastest selling motor-driven turnout motor range available world-wide. Cobalt motors are easy to install, have extensive onboard switching and iP motors use very little power. They need only about the same power as an LED to operate.

Reliability is exceptional & batch-by-batch life tests often show more than 200,000 changes before wear is evident.

This allows us to offer you a lifetime warranty on Cobalt iP motors.

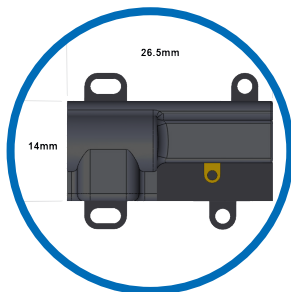

### The Cobalt SS Series "surface mount" micro turnout motors

Understanding the need for a surface-mount motor that is tiny, stable, robust & reliable, we tried many forms of power.

We found most weren't sufficiently stable, so we finally settled on a powerful and extremely reliable "stepper motor" approach.

Stronger and far, far more stable than servo or conventional DC motors, the tiny stepper motor that drives Cobalt-SS is controlled by a separate, hideable control board with many features that allows us to give Cobalt-SS all of the abilities of its larger brother.

Cobalt-SS is installable close to, or remote from, the turnout it controls.



### Our Cobalt-S Levers, Accessory Decoders and Accessories

Cobalt-S Signal Box levers look very like the real thing! Each has three onboard S.P.S.T. switches too, so they really can control almost anything you can imagine!

Cobalt Accessory decoders work well on both DC and DCC power and include all of the things missing from most solenoid decoders too. There is NO complicated setup needed!

Each item in the Cobalt range has a matching set of accessories to let you use it easily - without added complication.



### Cobalt ALPHA & Cobalt Alpha MIMIC control panel interfaces.

One simple question led us to Cobalt Alpha... "We have DCC and digital control - so why do we need all of the extra wires?" We extended that thought to both DC and DCC modellers and Alpha is the result.

Cobalt Alpha converts input from switches of all types to digital commands. It works from products like AlphaSwitch-D to standard push-button switches and even the old fashioned "Stud & Probe".

Alpha Mimic mirrors commands from Alpha & other DCC systems, converting them to LED outputs to create simple Mimic Panels. Together... they reduce control panel wiring by more than 90%

# COBALT IP AND OMEGA MOTORS

## COBALT IP DIGITAL, IP ANALOG AND OMEGA

Cobalt iP Digital, iP Analog & Omega are the third generation of Cobalt under-board turnout motors.

Cobalt's incredible durability is thanks to use of the correct engineering plastics for gears and case, MIL spec fibreglass circuit boards with hardened plating in the switch area, and gold plated switch contacts.

Versatility is excellent with up to 3 changeover switches on each model. More than enough for frog power, feedback, signal control, panel LEDs, interlocking or safety "isolation" sections at each turnout.

Cobalt iP Digital has digital control built-in so wiring is simplified, control is possible by DC or DCC, and DCC users can retain the ability to have both manual and DCC control. Cobalt iP Analog can be powered by DC or via an accessory decoder. Cobalt Omega was created primarily for those who prefer analog control & analog switching, however it is also able to be driven by DCC decoders if the user prefers it.

Cobalt power supply choice is flexible, with DCC or DC at most model railway voltages being acceptable.

Current draw is very low: 5mA when static or 40mA while changing for Cobalt iP Analog and Digital. 20-40mA for Cobalt Omega (Cobalt Omega power use varies with the level of power supplied to it).

<b>PRODUCT RANGE :</b>	DCCconcepts Cobalt under-board turnout motors
<b>APPROPRIATE SCALE USE:</b>	T, Z, N, HO, OO, O, G, Gauge 1 (Outdoor use acceptable).
<b>Case &amp; Gear material:</b>	Case-engineering plastic~Acetal, Gear-specialised Nylon.
<b>PCB &amp; OTHER MATERIAL:</b>	PCB Fibreglass. Contact areas hardened. Contacts Gold.
<b>PHYSICAL SIZE :</b>	Top 28 x 38mm. Depth 52mm (or 68mm over contacts).
<b>Power consumption:</b>	iP series 5mA~40mA, Omega Series 20mA~30mA.
<b>ACCEPTABLE VOLTAGE USE:</b>	iP Digital - DCC bus, iP Analog 7-23v DC, Omega 9-18V DC.
<b>AVAILABLE PACK SIZES:</b>	All models available in Single, 6-pack, 12 pack, 72 pack.

## THE LAST TURNOUT MOTORS YOU WILL EVER BUY?

WITH A LIFETIME WARRANTY & EXTREME RELIABILITY, YOU'LL NEED NOTHING MORE.

### COBALT IP DIGITAL - DC OR DCC, SIMPLE TO WIRE

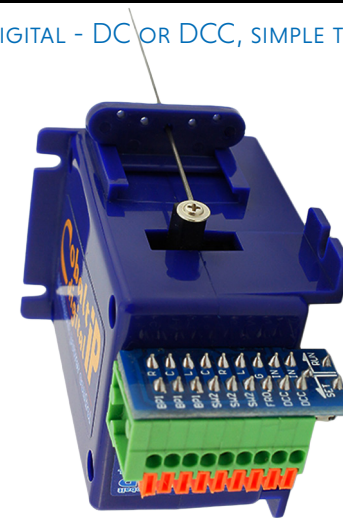

### COBALT IP DIGITAL PCB

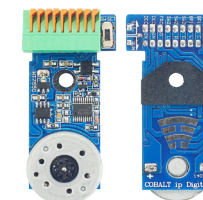

### COBALT IP ANALOG PCB

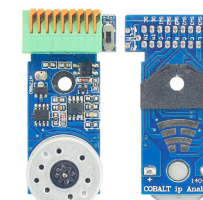

### COBALT GEAR TRAIN, MOTOR & FULCRUM COMPONENTS

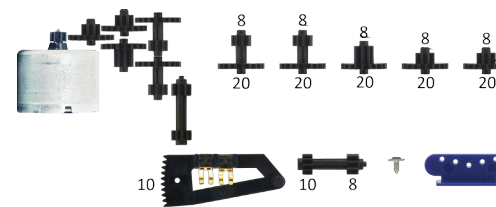

### COBALT OMEGA PCB

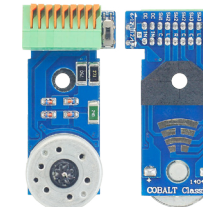



## COBALT iP DIGITAL

FOR DIGITAL AND SWITCH CONTROL ON DC AND DCC LAYOUTS



DCP-CB1DiP

## COBALT iP ANALOG

FOR DC SWITCH CONTROL OR USE WITH OUR ACCESSORY DECODERS

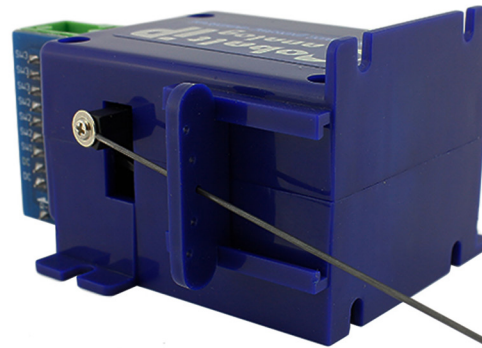

DCP-CB1iP

## COBALT OMEGA

FOR DC SWITCH CONTROL ON ANALOG AC OR DC LAYOUTS



DCP-CB1 Omega

### COBALT iP DIGITAL CONNECTION

Cobalt iP Digital is available singly and in packs of six or twelve ALL connections to Cobalt iP Digital are spring type. There is NO soldering required (Just strip the wires 10mm and twist tightly).

- Terminal 1 DCC track power / power bus input
- Terminal 2 DCC track power / power bus input
- Terminal 3 Switch 1 COMMON (turnout FROG power wire)
- Terminal 4 Switch 2 LEFT terminal (independent switch)
- Terminal 5 Switch 2 RIGHT terminal (independent switch)
- Terminal 6 Switch 2 COMMON terminal (independent switch)
- Terminal 7 Manual/switch control LEFT contact
- Terminal 8 Manual/switch control COMMON contact
- Terminal 9 Manual/switch control RIGHT contact
- Slide Switch Selects between "Set" (for addressing) & "Run"

### COBALT iP ANALOG CONNECTION

Cobalt iP Analog is available singly and in packs of six or twelve ALL connections to Cobalt iP Analog are spring type. There is NO soldering required (Just strip the wires 10mm and twist tightly).

- Terminal 1 DC power 7~23V (or Acc. decoder output)
- Terminal 2 DC power 7~23V (or Acc. decoder output)
- Terminal 3 Switch 1 COMMON (1/2/3 are a diode switch)
- Terminal 4 Switch 2 LEFT terminal (independent switch)
- Terminal 5 Switch 2 RIGHT terminal (independent switch)
- Terminal 6 Switch 2 COMMON terminal (independent switch)
- Terminal 7 Switch 3 COMMON terminal (independent switch)
- Terminal 8 Switch 3 LEFT terminal (independent switch)
- Terminal 9 Switch 3 RIGHT terminal (independent switch)
- Slide Switch Reverses the direction of the iP Analog throw

### COBALT OMEGA CONNECTION

Cobalt Omega is available singly and in packs of six or twelve ALL connections to Cobalt Omega are spring type. There is NO soldering required (Just strip the wires 10mm and twist tightly).

- Terminal 1 DC power 6~18V (or Accessory decoder output)
- Terminal 2 DC power 6~18V (or Accessory decoder output)
- Terminal 3 Switch 1 COMMON (1/2/3 are a diode switch)
- Terminal 4 Switch 2 LEFT terminal (independent switch)
- Terminal 5 Switch 2 RIGHT terminal (independent switch)
- Terminal 6 Switch 2 COMMON terminal (independent switch)
- Terminal 7 Switch 3 COMMON terminal (independent switch)
- Terminal 8 Switch 3 LEFT terminal (independent switch)
- Terminal 9 Switch 3 RIGHT terminal (independent switch)
- Slide Switch Change power range. Options 6~12V or 12~18V

## COBALT IP AND OMEGA ACCESSORIES

### KEEPING IT SIMPLE WHEREVER WE CAN

While Cobalt IP Digital, IP Analog and Omega are all quite easy for the average modeller to install and wire, sometimes its nice to have a few accessories that really make a difference.

The basic things like double-sided foam mounting pads and our very handy self adhesive tie-bar stickers will make the actual installation quick, simple & very tidy first time, greatly enhancing the pleasure of installation.... but the wiring still remains to be done.

DCCconcepts can help here too... for an analog approach, our 6-core wire will give a colour coded connection for as many wires as most will need (with an outer sheath that can be written on to identify the motor it controls) and if the choice is made to link Cobalt via our Cobalt Alpha products, then the result will be almost NO wiring at all required!

### THE COBALT "RIGHT ANGLE ADAPTER"

MOUNT COBALT MOTORS FLAT ON THE BOARD & REDUCE THEIR MOUNTING DEPTH

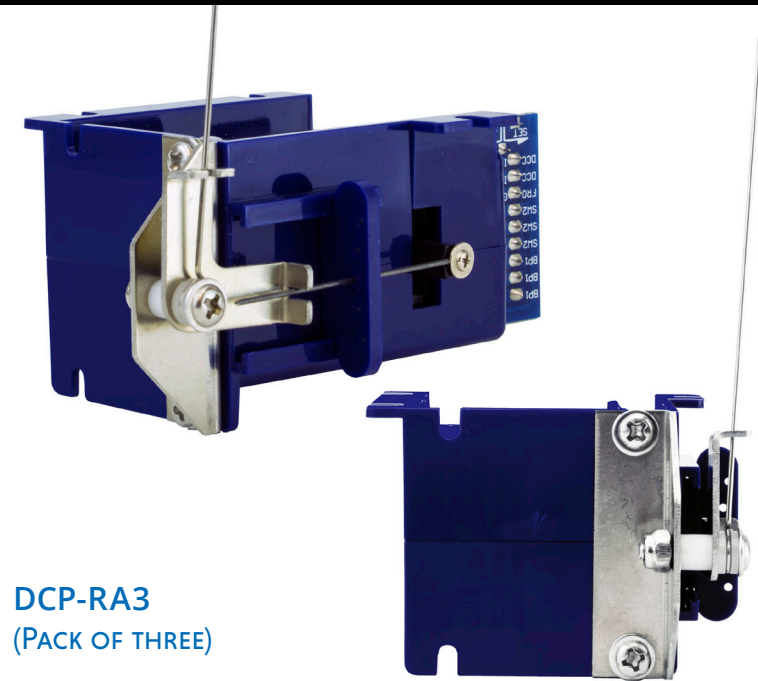

DCP-RA3  
(PACK OF THREE)

### BEST APPROACH FOR LIVE (ELECTRO-FROG) TURNOUTS

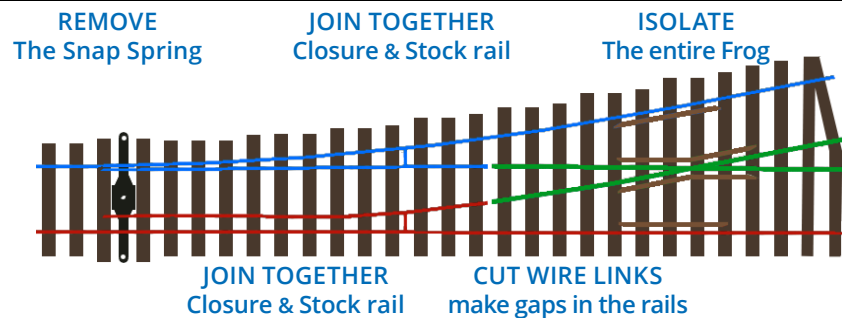

### REDUCING BASEBOARD RESONANCE FOR QUIET OPERATION

No matter how well we make our Cobalt motors, when you screw them to a baseboard, you are creating a resonant surface that will magnify any noise.

To give the best results, we suggest that you take a few simple steps to keep things quiet!

- Before installing, paint or seal the baseboard where you will place the Cobalt motor.
- Use the foam pads we supply (also available as an accessory pack DCP-CMFP).
- Position the motor with the foam pad, test, then add the screws to secure firmly.
- After 24 hours, slacken or even totally remove the screws for a quieter installation.

**Our foam pads are super strong & your motor will happily stay in place without screws!**

## ALPHA-SWITCH D

ALPHASWITCH D LINKS VIA ALPHA AEU TO CONTROL 6 COBALT IP DIGITAL OR DCC ACCESSORY DECODERS. IT MAKES WIRING MUCH SIMPLER.

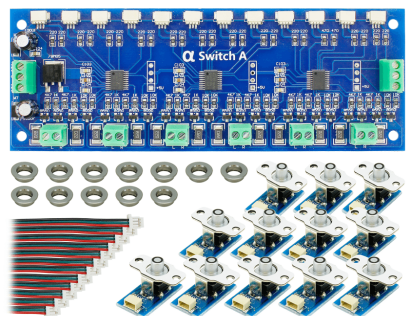

DCD-DSG/R/B

# WORKING SMARTER

## PREPARATION MAKES INSTALLATION EASIER, NEATER AND MUCH MORE FUN!

Preparing the things that will be used in advance will make the entire process easier. We think that these simple steps will save time and effort and give you the best possible result.

Prepare the turnouts: some will need very little - however assuming that you will use Peco or similar products, we do strongly recommend that you remove any "snap springs" as they are quite unnecessary with motor-drive turnout motors.

To get the best running performance with live frog turnouts (Electro-frog), make sure that the frog is totally isolated, and also bond each closure rail to its adjacent running or stock rail. To isolate the frog, cut the wire links under the turnout between frog & closure rails. To electrically bond the closure rails to the stock rails, solder a solid wire link between them.

Prepare the baseboard. Pre-drill the holes for the throw or actuation wire of your Cobalt motors under the turnout tie-bars. It is also a good idea to slightly countersink this hole top and bottom to make it neat and tidy.

Pre-fit the DCP-CML Ballast Stickers so that the throw-wire hole is already covered when the turnout is fixed down.

Obtain a magnetic screwdriver to use with the securing screws - it will make it much easier when working under the board.

## COBALT ADDED VALUE PACK. FOAM PADS, TIE BAR STICKERS, SPARE SCREWS, AND ALL OF THE DRILLS YOU WILL NEED TO CREATE THE TIE-BAR HOLE



## TIE BAR BALLAST STICKERS (OO/HO)



DCP-CML

## SELF-ADHESIVE MOUNTING PADS

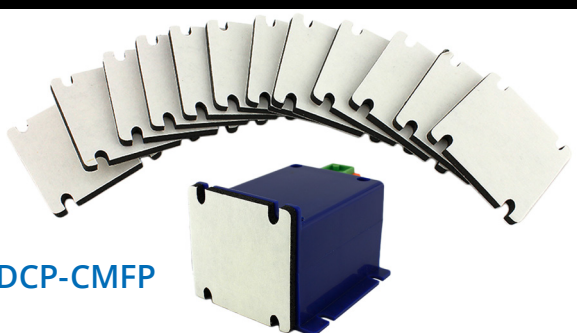

DCP-CMFP



DCP-PSU-2

9V + 9V DC OR 18V DC @ 5 AMPS POWER SUPPLY.

## COBALT PSU-2 POWER SUPPLY

REGULATED DC POWER SUPPLY FOR 220-260V AC AREAS OF THE WORLD ONLY  
OUTPUT CAN BE CONFIGURED AS 18V OR AS A SPLIT-RAIL -9V, 0V, +9V DC

PSU-2 is not currently available in Australia

# COBALT IP MOTORS MAKE IT VERY EASY FOR YOU

COBALT PRODUCTS ALL WORK TOGETHER TO MAKE INSTALLATION, WIRING AND CONTROL EASIER. COBALT CAN HAVE BOTH DIGITAL AND ANALOG SWITCH CONTROL AND IT WORKS WELL WITH DC OR DCC



IT DOESN'T MATTER WHETHER YOU DRIVE YOUR TRAINS WITH DC OR DCC: IT REALLY CAN BE THIS EASY TO WIRE IT ALL UP! Just use Alpha Central as we did here, or use Alpha AEU with Alpha-Switch D or almost any other turnout switching. Alpha Sniffer creates a digital accessory bus to power Cobalt IP digital or Cobalt-SS - meaning that you need only two wires to the Accessory bus for DCC & manual control. Quick, easy and almost no soldering!

12-18V DC, 1-2.5 AMPS

COBALT DRAWS VERY LITTLE POWER WHEN STATIC, SO YOU CAN ADD LOTS OF THEM TO THE LOW-POWER "ALPHA SNIFFER BUS".

# COBALT IP & OMEGA: USEFUL PRODUCTS TO ASSIST INSTALLATION

## VERSATILITY IN CONNECTION...

You may see some of these products in more than one place in this catalog, but we wanted to show you how well Cobalt and Cobalt Alpha work together to make wiring and control easier whilst reducing the number of wires you will need to use.

DC and DCC modellers should both take special note of the Alpha Sniffer DCD-SNX.

For DC modellers, this small and economical product lets you create a totally separated digital power bus that is not associated with your DC track power, so you are able to continue to drive trains with DC while at the same time taking advantage of the simpler wiring needed for things like digital control of point motors & panel lighting, significantly reducing your wiring complexity. For DCC users, it will enhance sniffer port usability and allow simple addition of digital mimic panel control via Alpha products.

## COBALT REX

A CONFIGURABLE RELAY SWITCH DEVICE THAT WORKS IN MANY WAYS

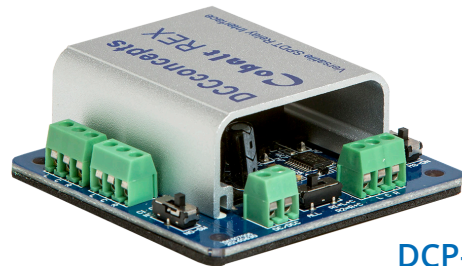

DCP-REX

## COBALT ALPHA SNIFFER

AN EFFECTIVE WAY TO ESTABLISH A SEPARATED DIGITAL POWER BUS



DCD-SNX

## ALPHA-SWITCH A FOR OMEGA

AN ALPHA-STYLE SWITCH SET WITH A VERY SIMPLE WIRING STRUCTURE

ALPHA-SWITCH A CONTROLS 6 COBALT OMEGA OR IP ANALOG MOTORS. IT HAS TACT SWITCHES WITH LEDs. USE SPS12 OR PSU-2 POWER SUPPLY. RED, BLUE OR GREEN LEDs

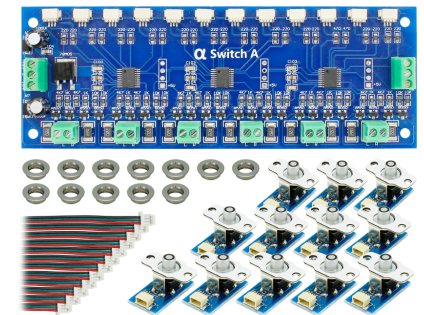

DCD-ASR/B/G

## CABLING THAT IS NEAT & TIDY

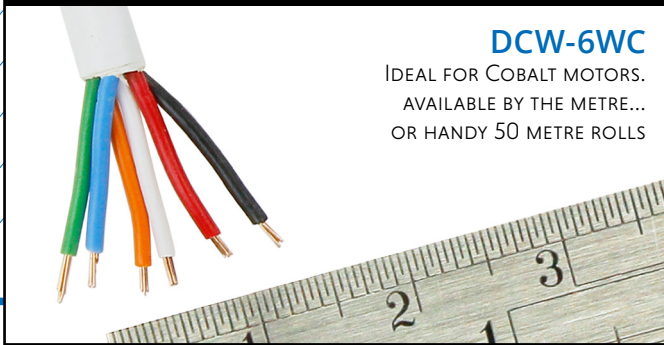

**DCW-6WC**  
IDEAL FOR COBALT MOTORS.  
AVAILABLE BY THE METRE...  
OR HANDY 50 METRE ROLLS

## INSTALL WITHOUT STRESS

## BRASS BARS TO LINK BUS WIRING



**DCC-Bbar2** (PACK OF 2)  
JOINING AN "ACCESSORY BUS" IS NEVER EASY BUT THESE SOLID BRASS  
BUS BARS KEEP IT ALL TIDY. HOLES 1x 6MM, 6x4.5MM

## TAGS MAKE CONNECTION EASY

### DCW-Tag25 or Tag50

RUN THE ACCESSORY POWER BUS VIA THE  
OUTSIDE TOP LOOPS.

USE THE LOWER HOLES TO  
ATTACH DROPPERS FOR EACH  
COBALT MOTOR.

USE THE CENTRE TAG AND  
EYELET HOLE FOR THE  
FROG WIRE... PERFECT!

PACKS OF 25 OR 50.

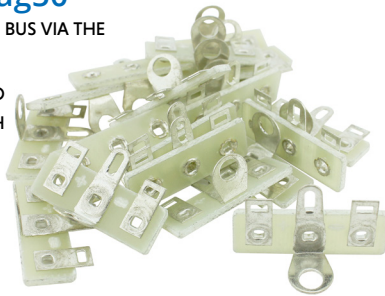

## SIMPLE THINGS THAT WILL HELP IT ALL GO SMOOTHLY

On this page is a random selection from our range that will contribute to an easy, pleasant wiring experience for you.

In particular, modellers seem to have trouble soldering. In reality though.. it's not hard if you have the right tools! Use a soldering iron of 50 Watts or more with a T2 or chisel tip. If it is adjustable, set it to about 390 degrees Centigrade.

Use DCCconcepts no-clean flux as it will make solder flow like water and will not harm your wire. Use DCCconcepts S179 solder as it contains a small amount of silver, making it ideal for nickel silver and some stainless steel grades such as that used in some Marklin track or DCCconcepts bullhead track (set your soldering iron to full power for stainless steel).

Strip the wire with our top quality wire strippers that are equally at home with dropper wire or large power bus wires, and can strip either at the wire ends or by pulling apart and separating the insulation within the length of the wire.

Simplify connection and keep it neat with NO need for insulating tape or wire ties by using our tags. Make connection of larger power wires easy with our brass bus bars or use our 6-wire sheathed cable to keep groups of connections tidy!

**You will be very surprised how well it all turns out when you use the right thing for every task!**

## COBALT SPS 12 POWER SUPPLY

SPLIT-RAIL -12V ~0V~ +12V POWER SUPPLY FOR COBALT OMEGA



### DCP-SPS12

GLOBAL USE WITH  
110~250V AC POWER.

OUTPUT IS +/- 12V DC

WIRING COBALT OR ANY MOTOR  
DRIVE TURNOUT MOTOR THAT NEEDS  
REVERSING DC POWER. WITH THIS POWER  
SUPPLY & OUR RANGE OF SWITCH PACKS IT WILL  
GREATLY SIMPLIFY ANALOG CONTROL AND REDUCE WIRING COMPLEXITY.

(PLEASE NOTE: SPS-12 IS NOT CURRENTLY AVAILABLE IN AUSTRALIA)

## DCCCONCEPTS WIRE STRIPPERS

STRIP WIRE PERFECTLY - THE IDEAL TOOL FOR EFFICIENT LAYOUT WIRING



### DCT-BWS

A VERY HIGH QUALITY TOOL...  
THESE STRIPPERS WILL LITERALLY SAVE  
YOU HOURS OF WORK, MAKING WIRING EASY!

## SAPPHIRE 179 SOLDER & FLUX

OUR 179 SOLDER AND NO-CLEAN FLUX WILL MAKE YOU AN EXPERT!

DCCCONCEPTS 179 SOLDER  
FLOWS SO WELL IT REALLY IS THE  
BEST CHOICE FOR WIRING.

OUR SFNC NO-CLEAN FLUX IS  
SAFE TO USE AND WORKS NICELY  
ON PCBs, COPPER WIRE AND  
MODELLING METALS LIKE BRASS,  
STAINLESS STEEL & NICKEL SILVER.

### DCS-SFNC



### DCS-S179



# COBALT IP DIGITAL, IP ANALOG & OMEGA APPLICATION NOTES (USING WITH SPECIAL TRACKWORK, UTILISING THE MOTOR CONTROLS & CONNECTIONS)

## COBALT IP DIGITAL, IP ANALOG AND OMEGA CONNECTIONS

EVERYTHING YOU WILL NEED TO CONNECT, CONTROL AND USE WITH YOUR COBALT MOTORS - READY TO USE AND CLEARLY LABELLED.

PLEASE BE SURE TO READ THE DETAILED MANUAL WE PROVIDE WITH ALL OUR COBALT MOTORS BEFORE YOU INSTALL OR CONNECT TO POWER.

### Cobalt $\Omega$ Omega

INDEPENDENT S.P.D.T SWITCHES (L-R-COMMON))  
THESE SWITCHES HAVE 5 AMP TERMINALS. USE TO SWITCH TRACK SECTIONS, INTERLOCKING OR OTHER PURPOSE

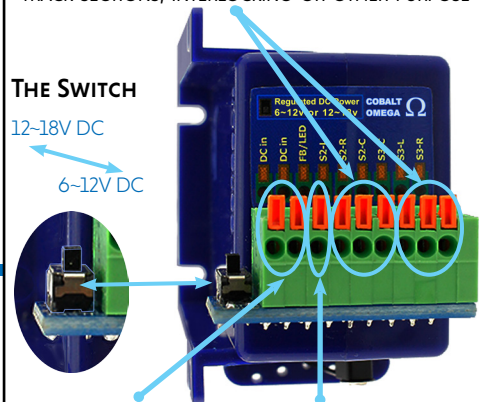

**DC POWER INPUT**  
FOR THE VERY BEST RESULTS PLEASE USE REGULATED DC POWER IF AT ALL POSSIBLE.  
ACCEPTS 6 TO 18V DC. (REVERSE WIRES TO SWAP TURNOUT DIRECTION)  
SET THE SWITCH ON THE PCB TO MATCH THE DC POWER VOLTAGE RANGE

**THIS IS THE COMMON FOR A SWITCH LINKED TO THE TWO DC POWER INPUT TERMINALS TO THE LEFT.**  
THIS SWITCH USES DIODES TO DIRECT DC POWER SO IT IS ABLE TO SWITCH THE POWER TO RELAYS, LEDS (WITH THE APPROPRIATE RESISTOR) OR SIMILAR.

### Cobalt iP Analog

INDEPENDENT S.P.D.T SWITCHES (L-R-COMMON))  
THE SWITCHES HAVE 5 AMP TERMINALS. USE TO SWITCH TRACK SECTIONS, INTERLOCKING OR OTHER PURPOSE

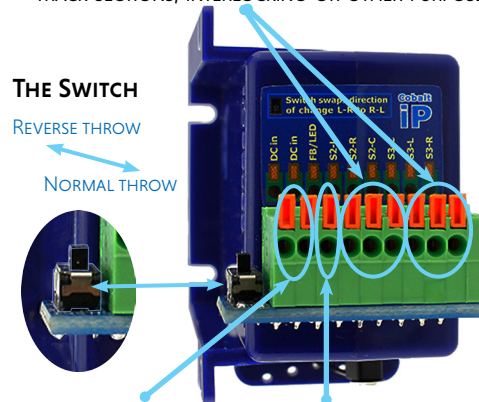

**DC POWER INPUT**  
FOR THE VERY BEST RESULTS PLEASE USE REGULATED DC POWER IF AT ALL POSSIBLE.  
ACCEPTS 9 TO 21V DC. (REVERSE WIRES TO SWAP TURNOUT DIRECTION).  
SET THE SWITCH ON THE PCB TO CHANGE DEFAULT POINT THROW DIRECTION.

**THIS IS THE COMMON FOR A SWITCH LINKED TO THE TWO DC POWER INPUT TERMINALS TO THE LEFT.**  
THIS SWITCH USES DIODES TO DIRECT DC POWER SO IT IS ABLE TO SWITCH THE POWER TO RELAYS, LEDS (WITH THE APPROPRIATE RESISTOR) OR SIMILAR.

### Cobalt iP Digital

INDEPENDENT S.P.D.T SWITCH (L-R-COMMON))  
THIS SWITCH HAS 5 AMP TERMINALS. USE TO SWITCH TRACK SECTIONS, INTERLOCKING OR OTHER PURPOSE

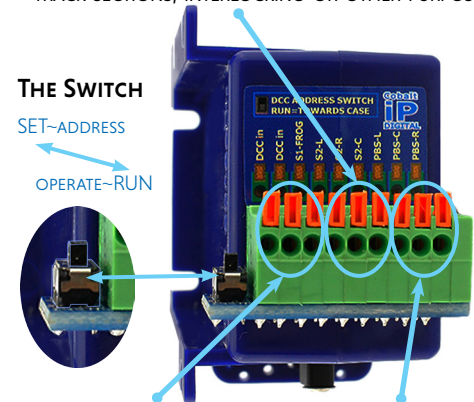

**DCC OR DC POWER AND FROG POWER CONTROL (L-RAIL - R-RAIL - FROG)**  
DCC POWER IS OK AT ALL DCC STANDARD VOLTAGE LEVELS. DC POWER IS ALSO OK FROM 9-21V (REGULATED DC PLEASE)  
MOTOR STATIC LOAD IS 0.005 A WHEN MOVING LOAD IS 0.04 A (APPROXIMATE/AVERAGE)

**MANUAL SWITCH (LEFT-COMMON-RIGHT)**  
CONNECT TWO PUSH BUTTON SWITCHES OR AN S.P.D.T. TYPE TOGGLE SWITCH.  
ALSO OK TO USE LOW POWER DETECTORS. THE TERMINALS ARE: LEFT - COM - RIGHT

## COBALT RANGE VERSATILITY

COBALT MOTORS HAVE A VERY WIDE RANGE OF FEATURES AND EVERYTHING THAT YOU MAY NEED IS ALREADY BUILT IN TO GIVE YOU EXTREMELY VERSATILE CONNECTION AND CONTROL.

COBALT IP DIGITAL MOTORS CAN BE OPERATED WITH DCC OR DC. OF COURSE, COBALT IP ANALOG AND OMEGA WILL NEED AN ACCESSORY DECODER TO WORK WITH DCC.

THE CONNECTIONS ARE ALL CLEARLY LABELLED AND NEED NO SOLDERING.

COBALT HAS BUILT-IN SWITCHES FOR FROG CONTROL PLUS SPARE S.P.D.T. SWITCHES TO ALLOW YOU TO CONTROL ALMOST ANYTHING YOU CAN IMAGINE.

YOU CAN ALSO USE THE COBALT SWITCHES TO CONTROL OTHER COBALT MOTORS WITH SIMPLE INTERLOCKING OR FOR BETTER CONTROL OF MORE COMPLEX THINGS LIKE 3-WAY POINTS.

COBALT MAKES IT ALL SO MUCH EASIER!

# CONNECTING COBALT IP DIGITAL - AN ELECTROFROG CROSSOVER (OR LOOP) WITH FROG POWER CONTROL

THIS DIAGRAM USES COBALT IP DIGITAL TURNOUT MOTORS.

THE SAME APPROACH & GENERAL INSTALLATION VERSATILITY APPLIES TO ALL OF OUR COBALT POINT MOTORS & COBALT ACCESSORY DECODERS.

**PLEASE NOTE:**

COBALT IP ANALOG AND OMEGA MODELS CHANGE BY REVERSING POWER TO THEIR INPUT TERMINALS SO AN SPDT SWITCH AND SPLIT-RAIL POWER SUPPLY OR A DC POWER SUPPLY & CROSS-WIRED DPDT SWITCH ARE REQUIRED.

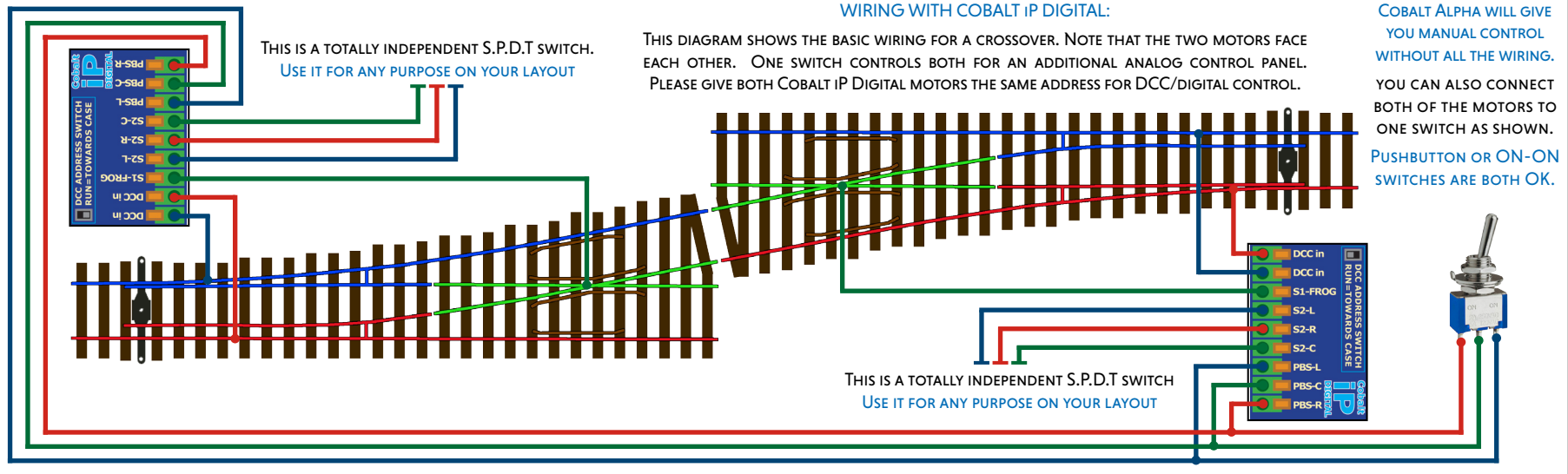

COBALT ALPHA WILL GIVE YOU MANUAL CONTROL WITHOUT ALL THE WIRING. YOU CAN ALSO CONNECT BOTH OF THE MOTORS TO ONE SWITCH AS SHOWN. PUSHBUTTON OR ON-ON SWITCHES ARE BOTH OK.

# CONNECTING COBALT IP DIGITAL - A THREE-WAY PECO POINT WITH MOTORS INTERLOCKED FOR PROPER CONTROL

**WE ARE OFTEN ASKED:**

"HOW CAN I CONNECT THE 2 MOTORS ON A 3-WAY POINT TO LOCK OUT THE 4TH INVALID POSITION AND ALWAYS GIVE THE CORRECT ROUTE OR TRACK DIRECTION".

THE EASIEST WAY IS TO USE A VERY SIMPLE FORM OF "DIODE MATRIX" BETWEEN THE THREE SWITCHES & THE SWITCH TERMINALS ON THE TWO COBALT IP DIGITAL MOTORS.

**PLEASE NOTE:**

YOU CAN ALSO WIRE A 3-WAY POINT THE SAME WAY WITH A COBALT-SS MOTOR CONTROL BOARD OR THE DCCCONCEPTS AD / ADS ACCESSORY DECODER FAMILY OF PRODUCTS AS THEY SHARE THE SAME KIND OF SWITCHING LOGIC.

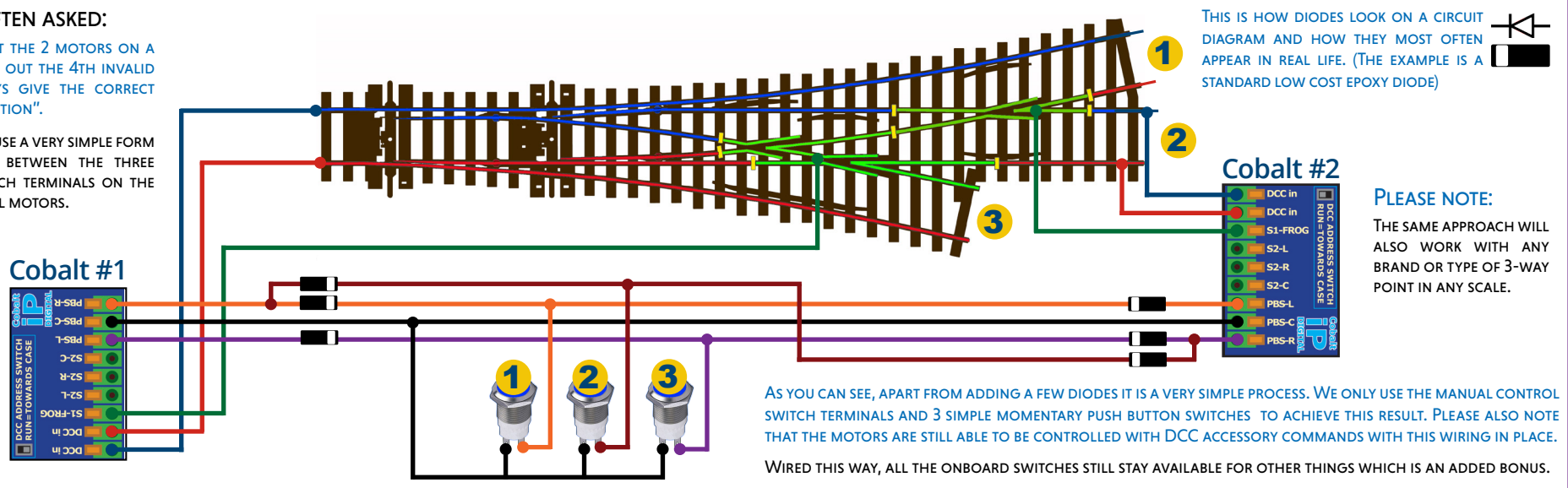

AS YOU CAN SEE, APART FROM ADDING A FEW DIODES IT IS A VERY SIMPLE PROCESS. WE ONLY USE THE MANUAL CONTROL SWITCH TERMINALS AND 3 SIMPLE MOMENTARY PUSH BUTTON SWITCHES TO ACHIEVE THIS RESULT. PLEASE ALSO NOTE THAT THE MOTORS ARE STILL ABLE TO BE CONTROLLED WITH DCC ACCESSORY COMMANDS WITH THIS WIRING IN PLACE. WIRED THIS WAY, ALL THE ONBOARD SWITCHES STILL STAY AVAILABLE FOR OTHER THINGS WHICH IS AN ADDED BONUS.

## COBALT-SS TURNOUT MOTORS: THE ABOVE BOARD TURNOUT MOTOR SOLUTION.

### THE OBJECTIVE: CREATE SOMETHING SPECIAL

**WHY COBALT-SS?** NOT EVERY MODELLER WANTS TO PUT THEIR MOTORS BELOW THE BOARD AND SOME SIMPLY CANNOT BECAUSE OF THE LAYOUT DESIGN. COBALT-SS IS THE BEST ANSWER FOR THOSE PROBLEMS.

COBALT-SS IS SMALL & SUBTLE, ABLE TO MOUNT CLOSE TO OR FAR FROM THE TURNOUT IT CONTROLS. IT HAS A FULL COMPLIMENT OF ONBOARD FUNCTIONS TO MATCH ITS LARGER COBALT IP RELATIONS.

COBALT-SS IS VERY STABLE BECAUSE IT USES STEPPER MOTORS RATHER THAN SERVO MOTORS. POWERFUL ENOUGH FOR ALL COMMON GAUGES, ITS SMALL SIZE MAKES IT SMALL ENOUGH TO USE WITH ALL OF THEM.

COBALT-SS WORKS EQUALLY WELL WITH DC OR DCC. IT IS ABLE TO BE OPERATED WITH SWITCHES OR VIA DIGITAL COMMANDS . CONNECTION IS A SIMPLE "PLUG AND PLAY" PROCESS. ALL CONNECTIONS ARE ON AN EASY-TO-USE CONTROL BOARD ABLE TO POWER SEVERAL MOTORS FROM EACH OF ITS OUTPUTS, SO IT IS ALSO VERY ECONOMICAL BECAUSE LOOPS OR CROSSOVERS CAN BE DRIVEN FROM A SINGLE OUTPUT.

## COBALT-SS

**WHY COBALT-SS?** SMALL, SILENT, SMART, SUBTLE, SMOOTH - CHOOSE ANY!

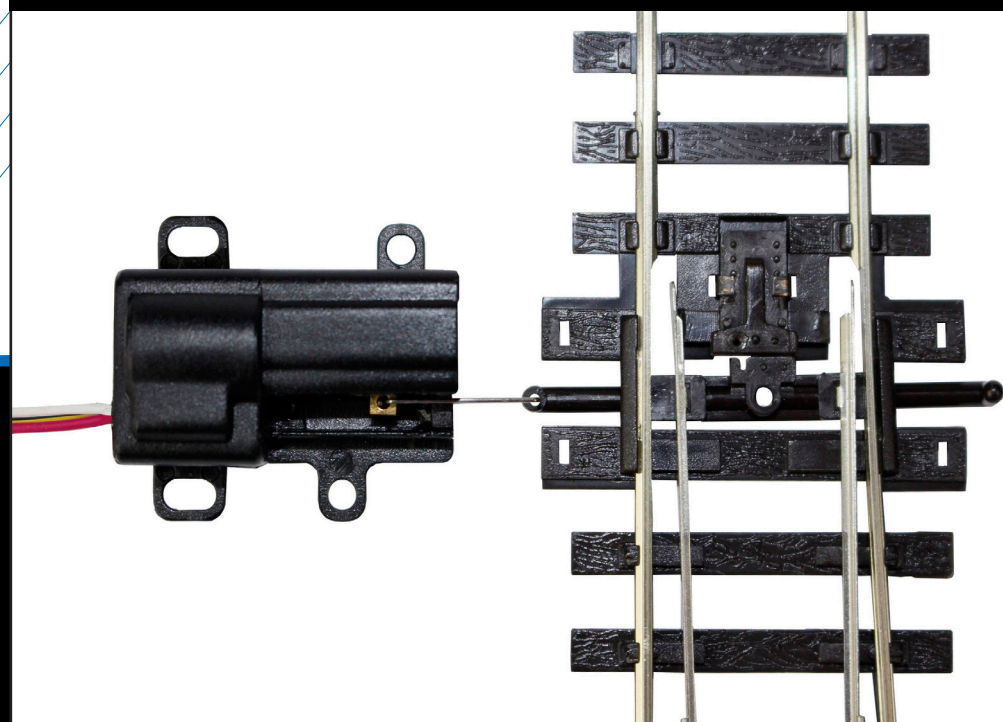

**PRODUCT RANGE :** DCCCONCEPTS COBALT-SS ABOVE-BOARD TURNOUT MOTORS.

**APPROPRIATE SCALE USE:** T, Z, N, HO, OO, O. (THE THROW IS ADJUSTABLE TO SUIT)

**CASE & GEAR MATERIAL:** CASE-ENGINEERING PLASTIC. GEARING AND DRIVE SILVER-STEEL. AND PHOSPHOR BRONZE. MOTOR FRAME PLATED METAL.

**PCB & OTHER MATERIAL:** PCB - FIBREGLASS. HARD PLATED RELAY CONTACTS.

**PHYSICAL SIZE :** FOOTPRINT ONLY 14 x 26MM.

**POWER CONSUMPTION:** STATIC POWER ZERO. DUAL CONTROL BOARD - APPX 50MA.

**ACCEPTABLE VOLTAGE USE:** ALL COMMON DIGITAL DCC BUS VOLTAGES, DC 9~21V.

**AVAILABLE PACK SIZES:** COBALT-SS IS SOLD AS A 2-PACK, 6-PACK, 12 PACK & 72 PACK. (ALSO A 2-MOTOR CROSSOVER PACK FOR LOOPS & CROSSOVERS).

## WHAT'S IN THE BOX WHEN YOU BUY COBALT-SS?

AS WELL AS COMPREHENSIVE INSTRUCTIONS, YOU WILL FIND THE FOLLOWING IN EVERY COBALT-SS PACK.

### COBALT-SS 2-PACK

- 2 Cobalt-SS motors
- 1 Control board
- Linkages & screws
- Y-Connect & Reverse lead
- Extension lead

### COBALT-SS 6-PACK

- 6 Cobalt-SS motors
- 3 Control boards
- Linkages & screws
- 2 x Y-Connect/Reverse leads
- 2 x Extension leads

### COBALT-SS 12-PACK

- 12 Cobalt-SS motors
- 6 Control boards
- Linkages & screws
- 3 x Y-Connect/Reverse leads
- 3 x Extension leads

### COBALT-SS CROSSOVER PACK.... MOTORS ONLY TO MAKE CROSSOVERS OR LOOPS.

- 2 Cobalt-SS motors, to attach to your Cobalt-SS control board for loops & crossovers
- Linkages and screws, plus a Y-Connector/Reverse lead and an Extension lead.



# THE COBALT-SS CONTROL BOARD

PLUG & PLAY CONNECTION, EASY SETUP AND SIMPLE ADJUSTMENT, USABLE WITH DC OR DCC

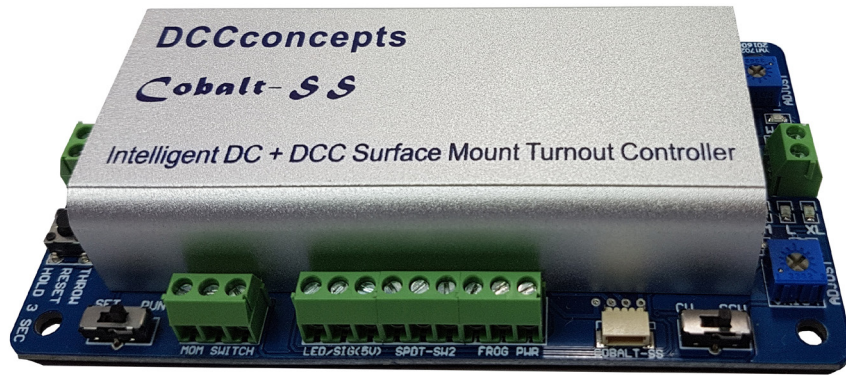

# TWO, SIX OR TWELVE COBALT-SS MOTORS!

ONCE YOU'VE TRIED IT, WE KNOW YOU WILL WANT MORE, SO WE OFFER SEVERAL CHOICES

COBALT-SS 2-PACK  
DCP-CBSS-2

COBALT-SS 6-PACK  
DCP-CBSS-6

Cobalt-SS 12-pack  
DCP-CBSS-12



# ADAPTER LEADS FOR EVERY NEED

Y-CONNECTIONS, REVERSE CONNECTORS & EXTENSION LEADS

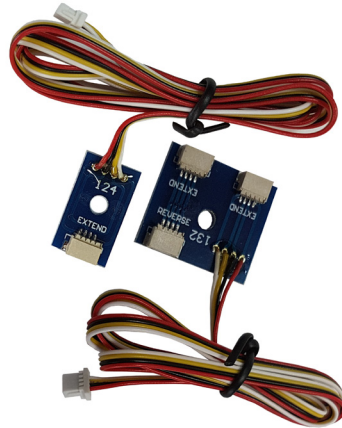

# CONNECTIONS AND SETUP FOR COBALT-SS

As with all our products, we thought carefully about the user and all connections or adjustment requirements for Cobalt-SS.

Cobalt-SS motors connect directly to the control board via miniature plugs and sockets and, as some motors will be far from the control board, a wide range of extension leads has also been created to keep it all plug-and-play.

Multiple motors can be connected to one output, so we have also created plug and play Y and reverse connectors, covering every possible combination we can think of.

Several useful adapters are also supplied in every pack.

LED panel lights or signals connect directly to the control board and each control board also has two spare SPDT switches per motor / on each output, allowing frog power and other things to be connected without complication.

Using Cobalt-SS is simple too. Addressing is a "Set and Learn" process and control can be via DCC or a simple switch. Even adjustment of motor throw is easy - with LED indicators.

# LOTS OF SCREWS AND LINKAGES!

WE SUPPLY ALL THE FITTINGS YOU WILL NEED IN THE PACK.

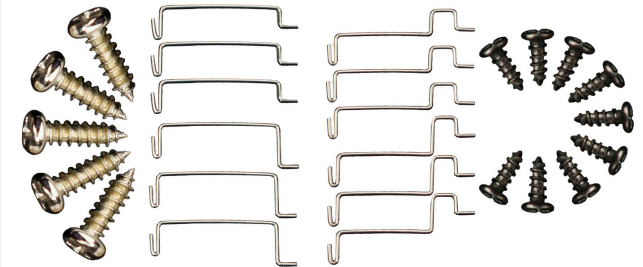

ALL OF THE ABOVE ITEMS ARE INCLUDED WITH THE TWIN (2) PACK AND OF COURSE, SIX & TWELVE PACKS HAVE MORE.

EACH PACK HAS FOUR LINKAGE STYLES FOR USE WITH VARIOUS SCALES AND TRACK-BED THICKNESSES. YOU CAN CHOOSE!

# COBALT IP DIGITAL AND COBALT-SS TURNOUT MOTORS ARE DESIGNED TO WORK TOGETHER ON YOUR LAYOUT

THEY SHARE THE SAME APPROACH TO ADDRESSING TOO, SO COMBINING BOTH TYPES OF MOTOR WILL NOT COMPLICATE LAYOUT CONTROL OR OPERATION. MIX & MATCH THEM TO YOUR LAYOUT'S NEED.

## PLUG & PLAY IN ANY POSSIBLE COMBINATION

PLUG AND PLAY SYSTEMS NEED TO BE ABLE TO GROW WITHOUT LOSING THEIR SIMPLICITY SO WE HAVE CREATED A WIDE RANGE OF LEADS AND USED DRAWINGS HERE FOR CLARITY.

Adapter-Short. 1x Ext. & 1 Rev. (Pack=3)

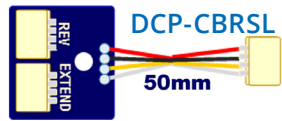

Adapter-Short. Y connect. (Pack=3)

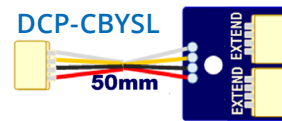

Adapter-Medium. 1x Ext. & 1 Reverse

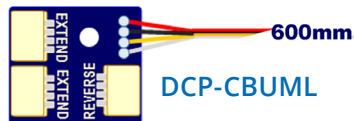

Adapter-Long  
1x Ext. & 1 Reverse  
(Pack of 3)

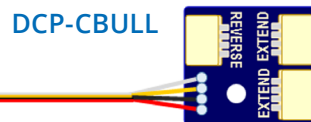

Extension-Medium



Wire only, 6m, with heat-shrink for joints DCP-CB6MC



# COBALT-SS TURNOUT MOTORS: INSTALLATION ACCESSORIES & ADAPTER LEADS

## KEEPING IT ALL PLUG AND PLAY

Each output on the Cobalt-SS control board comfortably drives more than one motor and as already explained, multiple Cobalt-SS motors can be connected in parallel via a standard Y connection or with one motor reversed via an adapter if required.

Of course, sometimes motors will also need to be located a distance from the control board and with Cobalt-SS so easy to install, the last thing you will want is to spend lots of time under the baseboard extending and joining wires.

We have therefore created a wide selection of extensions and adapters, including some with multiple connection options to keep your wiring as easy as possible.

Of course some DO like wiring, so we've made extension wire available too. The whole range of adapters and wire extensions is shown on the left. (Some images below)

### ADAPTER SET: 3 x 1000MM/1M

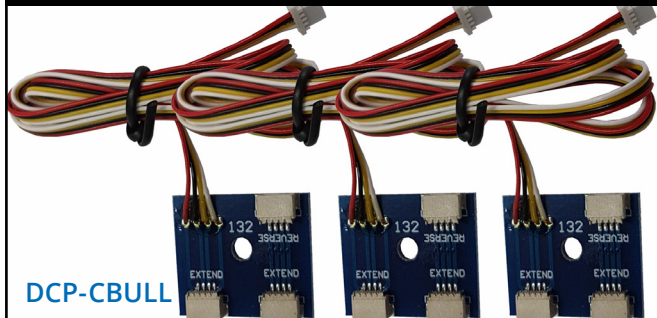

### EXTENSION SET: 3 x 600MM

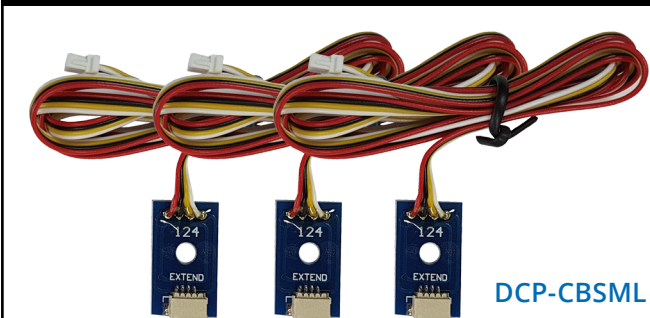

### SHORT ADAPTER SET: 3 x 50MM

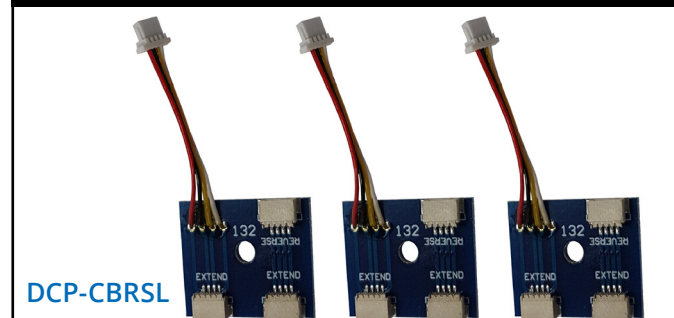

### TOP QUALITY FINE WIRE STRIPPERS

ADJUSTABLE DOWN TO THE SMALLEST WIRE YOU WILL EVER USE

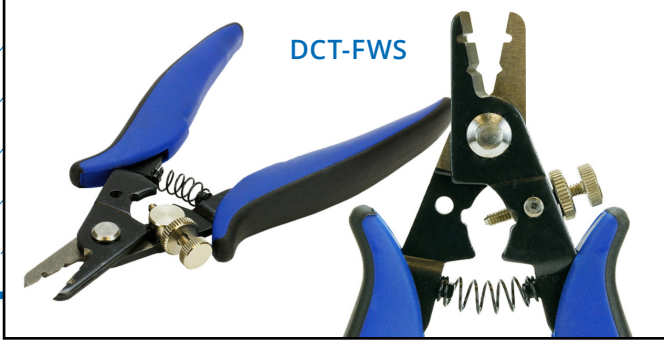

## INSTALL WITHOUT STRESS SMALL THINGS MAKE IT EASIER

### UNQUESTIONABLE RELIABILITY

LONG LIFE IS ASSURED WITH LIFE-TESTING FOR EVERY BATCH!

COBALT-SS CROSSOVER CHANGED MORE THAN 200,000 TIMES!

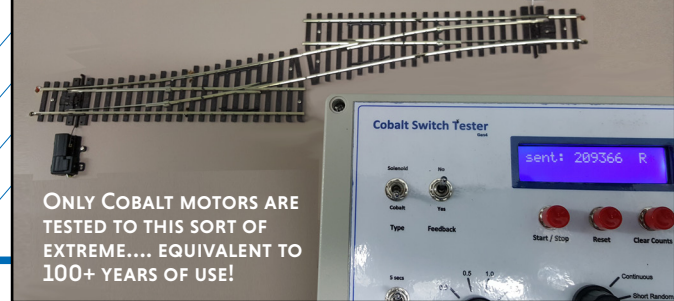

ONLY COBALT MOTORS ARE TESTED TO THIS SORT OF EXTREME... EQUIVALENT TO 100+ YEARS OF USE!

### RED~GREEN~BLACK SWITCH WIRE

A NEAT & TIDY WAY TO MAKE COBALT-SS SWITCH CONNECTIONS

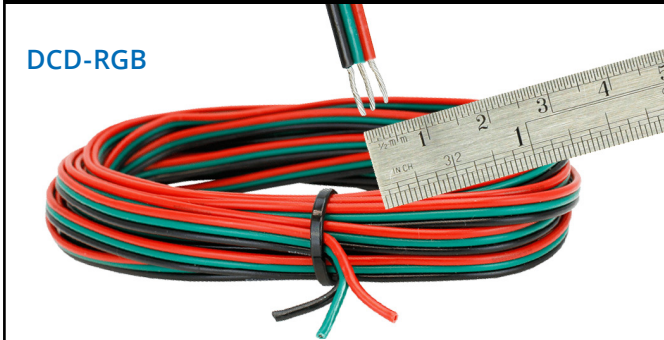

## CHOOSE THE RIGHT EQUIPMENT & ADD SOME IMPORTANT DETAILS!

DCCconcepts fine wire strippers are without peer in the hobby: adjustable and lockable, they can be pre-set to any common modelling wire size, even the super-fine diameters used in the most compact installations!

Using the right wire helps save time and with the 6-core cable mentioned earlier in the catalog and the 3-wire ribbon shown here, neat, logical and tidy installation of panel switching is assured.

Cobalt-SS uses screw terminals and the right tools matter here too. Forget low cost jewellers screwdrivers that fail at the slightest strain. Our magnetic screwdriver set includes 9 chrome vanadium tips for really long life plus three very comfortable magnetic handles, so the right tool is always at hand for your project.

Great model railways also need the visible details to be correct, so we have created the first ever detailed ready-to-use scale models of the Westinghouse EP (Electro Pneumatic) turnout motor used in many parts of the world since the 1930's... and we have crafted them in three useful modelling scales.

We provide one of each FREE in each Cobalt-SS pack, and more are available in economical packs of 12.

### SCALE WESTINGHOUSE EP MOTORS

AVAILABLE IN 12 PACKS, FOR O, OO/HO AND N SCALE

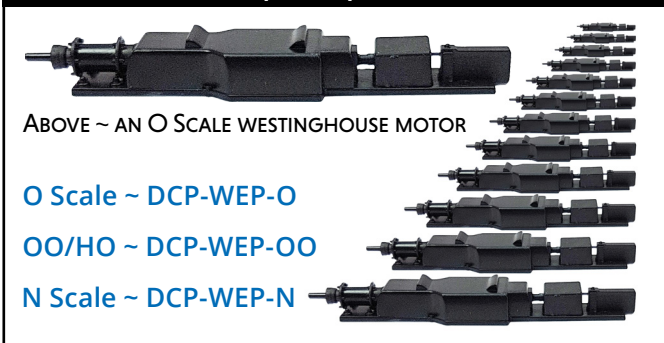

ABOVE ~ AN O SCALE WESTINGHOUSE MOTOR

O Scale ~ DCP-WEP-O

OO/HO ~ DCP-WEP-OO

N Scale ~ DCP-WEP-N

### HIGH QUALITY SCREWDRIVER SET

THREE HANDLES WITH EXCELLENT GRIP & CHROME VANADIUM TIPS.

QUALITY MATTERS WHEN IT COMES TO BUYING YOUR TOOLS.

WE SUPPLY THREE VERY COMFORTABLE MAGNETIC HANDLES + THREE OF EACH TYPE OF TIP (CROSS, MINUS AND HEX-NUT DRIVERS).



DCT-SND.12

### COBALT ALPHA CENTRAL

TURNOUT CONTROL WITHOUT THE NEED FOR ADDITIONAL WIRING!

ALPHA CENTRAL'S INSTRUCTIONS COULD READ "OPEN THE BOX PLUG ALPHA CENTRAL IN & OPERATE THE POINTS".

IT REALLY CAN BE THAT SIMPLE!

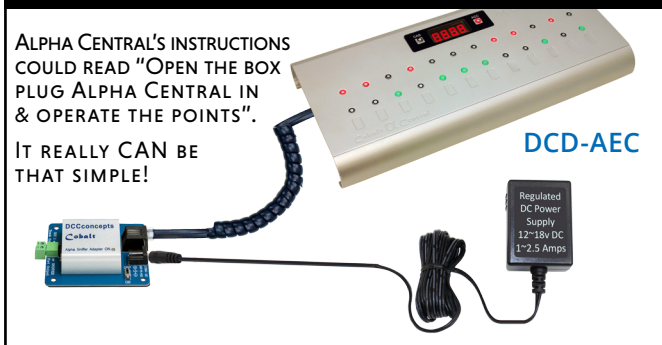

DCD-AEC

Regulated DC Power Supply 12V-18V DC 1-2.5 Amps

# COBALT-SS SURFACE MOUNT TURNOUT MOTOR APPLICATION NOTES (USING WITH SPECIAL TRACKWORK, UTILISING THE MOTOR CONTROLS & CONNECTIONS)

## THE COBALT-SS CONTROL BOARD.

EVERYTHING YOU WILL NEED TO CONNECT, CONTROL AND ADJUST YOUR COBALT-SS MOTORS - READY TO USE AND CLEARLY LABELLED.

PLEASE BE SURE TO READ THE DETAILED MANUAL WE PROVIDE WITH ALL OUR COBALT MOTORS BEFORE YOU INSTALL OR CONNECT TO POWER.

(1) BEFORE USING YOUR COBALT-SS, PLEASE BE SURE TO READ THE VERY DETAILED MANUAL PROVIDED WITH EVERY COBALT-SS POINT MOTOR.

(2) WE PROVIDE USEFUL WIRING DIAGRAMS IN THIS MANUAL. IF YOU CANNOT FIND AN ANSWER FOR YOUR PARTICULAR SITUATION PLEASE FEEL FREE TO EMAIL OR CALL US & ASK. WE'LL BE HAPPY TO HELP.

(3) THINK CREATIVELY AND YOU WILL FIND MANY POSSIBILITIES THANKS TO THE COMPREHENSIVE SET OF AUXILIARY CONNECTIONS ON EACH COBALT-SS CONTROL BOARD.

(4) YOU WILL FIND A RANGE OF LEADS AND ACCESSORIES ON P14.

(5) COBALT-SS MOTOR DRIVE UNITS ARE POWERED BY STEPPER MOTORS. THEY MUST ONLY BE USED WITH A COBALT-SS CONTROL BOARD. ANY OTHER FORM OF CONNECTION OR USE WILL CAUSE DAMAGE THAT WILL NOT BE COVERED BY WARRANTY.

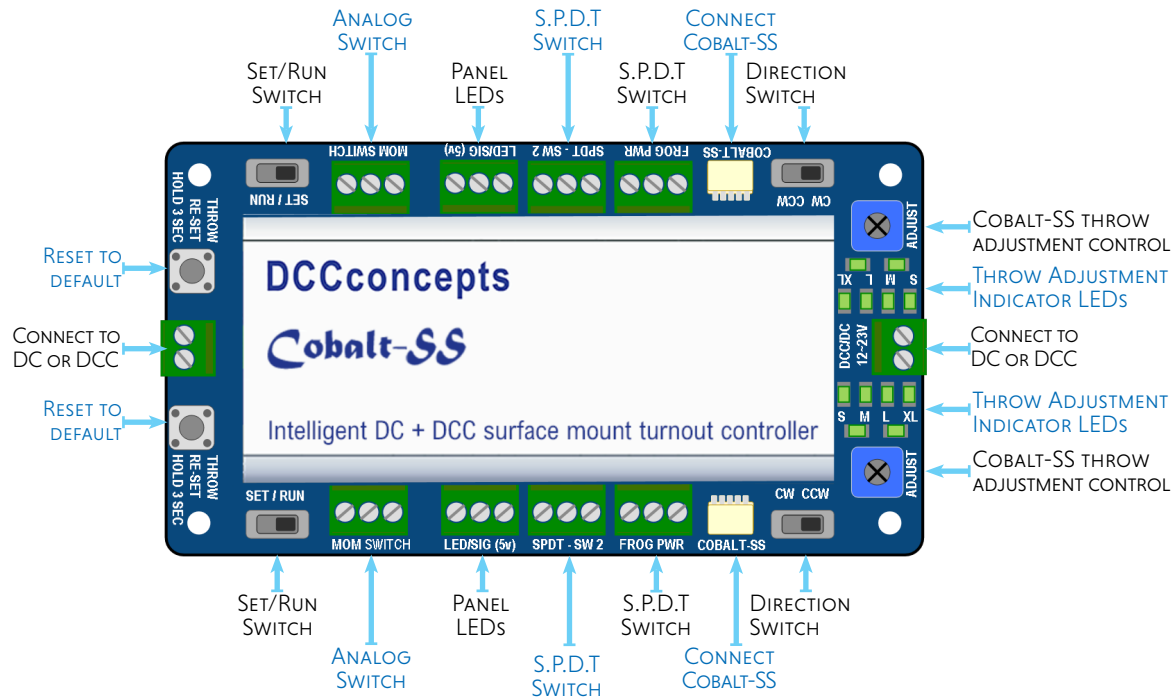

## COBALT-SS VERSATILITY

COBALT-SS HAS A VERY WIDE RANGE OF FEATURES, MAKING IT EASY TO USE AND EXCEPTIONALLY VERSATILE.

COBALT-SS CAN BE POWERED EITHER BY DCC OR DC POWER (OF COURSE, WITH DC POWER IT WILL BE CHANGED WITH THE ANALOG SWITCH CONTACTS)

THE CONTROL BOARD OUTPUTS CAN COMFORTABLY HANDLE MORE THAN ONE COBALT-SS MOTOR, SO TWO OF THEM CAN BE USED ON ONE OUTPUT TO ECONOMICALLY POWER A CROSSOVER.

THERE ARE THREE SWITCHES ON THE CONTROL BOARD FOR EACH OUTPUT, SO YOU CAN CONTROL PANEL LEDs OR SIGNALS, FROG POLARITY AND ANY OTHER THING YOU MIGHT IMAGINE.

COBALT-SS MOTORS CAN ALSO BE USED CONTROL EACH OTHER BY USING THE SWITCH ON ONE TO OPERATE VIA THE SWITCH TERMINALS OF THE OTHER. (THIS IS EXCELLENT FOR INTERLOCKING AND LINKING COMPLEX POINTWORK)

# CONNECTING COBALT-SS - A CROSSOVER OR PASSING LOOP (USING MORE THAN ONE MOTOR ON AN OUTPUT)

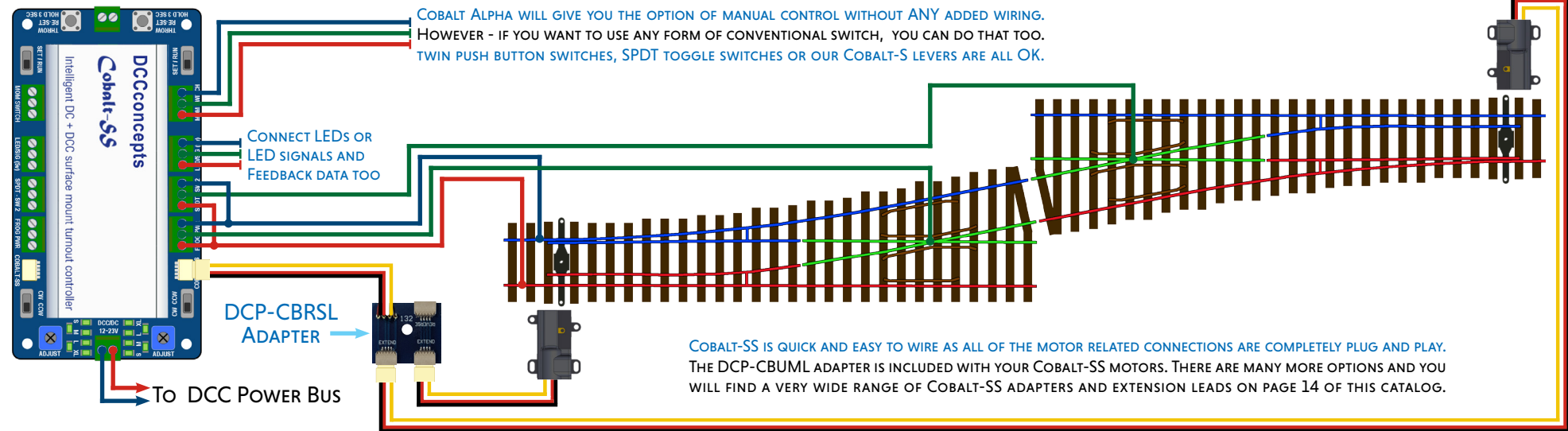

# CONNECTING COBALT-SS - INTERLOCKING A 3-WAY POINT (USING 2 OUTPUTS OF A COBALT-SS CONTROL BOARD)

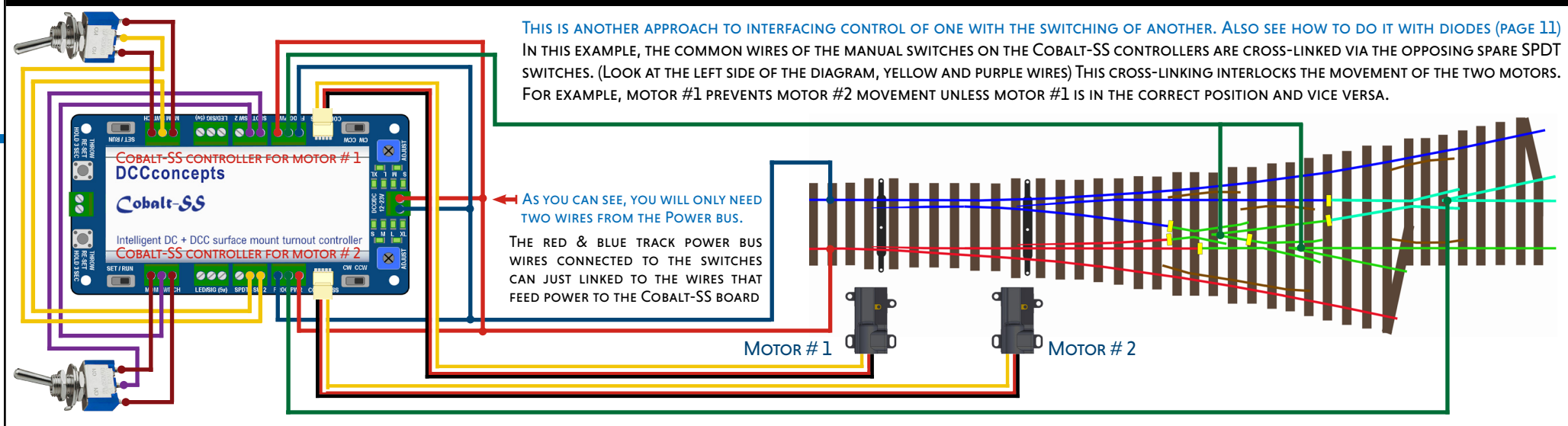



COBALT-S LEVERS, COMPLETED TO SHOW YOU WHAT CAN BE DONE.

(1) LEVERS HAVE BEEN CAREFULLY MASKED AND THEN PAINTED WITH AUTOMOTIVE ENAMELS.

(2) BRASS NUMBERS, PAINTED, THEN BROUGHT TO LIFE BY POLISHING THEM WITH FINE WET-AND-DRY ABRASIVE PAPER.

(3) THE CAST METAL LEVER TOPS, HAVE BEEN POLISHED WITH FINE WET-AND-DRY PAPER, THEN FIXED TO THE TOP OF THE LEVER BODIES.

(4) THE HANDLES AND LEVER GRIPS HAVE ALSO BEEN POLISHED TO SHINE JUST LIKE THE REAL THING.

## COBALT-S LEVERS...

### PRODUCT RANGE :

APPROPRIATE SCALE USE:

CASE & LEVER MATERIAL:

PCB & OTHER MATERIAL:

PHYSICAL SIZE :

POWER CONSUMPTION:

ACCEPTABLE POWER USE:

AVAILABLE PACK SIZES:

### DCCCONCEPTS COBALT-S SIGNAL BOX LEVERS

T, Z, N, HO, OO, O, G, GAUGE 1 (OUTDOOR USE IS OK WITH CARE)

CASE-ENGINEERING GRADE ACETAL, SOLID BRASS LEVERS (ANTIQUED)

PCB FIBREGLASS. CONTACT AREAS HARDENED AND GOLD PLATED

BASE SIZE: 16 X 60MM OVERALL. HEIGHT TO TOP OF LEVER ~140MM

NIL DIRECT: SUBJECT TO USER APPLICATION

USABLE WITH ALL COMMON MODEL RAILWAY VOLTAGES / CURRENTS.

ALL MODELS AVAILABLE IN SINGLE, 6-PACK, 12 PACK & 72 "CLUB PACK"



POLISH THE TOPS WITH WET-AND-DRY PAPER THEN GLUE THEM TO THE TOPS OF YOUR COBALT-S LEVERS.

PAINT & POLISH THE BRASS NUMBERS.



### WHAT IS IN THE PACK WHEN YOU PURCHASE YOUR COBALT-S LEVERS?

Cobalt-S Lever packs will contain either 1, 6 or 12 levers plus all of these accessories:

- Connection boards (PCB) & standard wiring harnesses (Quantity depends on pack size).
- Cast metal dress-up pieces for lever tops (Quantity depends on pack size).
- Etched brass numbers. Content depends on pack size (Accessory pack of 1-99 is also available).

### PAINT THE LEVERS, ADD THE DETAILS...

EACH LEVER IN THE SIGNAL BOX HAS A NUMBER & EVERY COLOUR HAS ITS OWN MEANING.

# THE JOY OF REALISTIC LAYOUT CONTROL

## THE REALITY

**COBALT-S IS VERY SPECIAL:**  
140MM (5-1/2") HIGH AND WITH A FEEL THAT HAS NEVER BEEN ACHIEVED BEFORE WITHOUT LONG HOURS OF SKILLED WORK ON THE MODELLERS WORK-BENCH.

COBALT-S HAS A SOLID BRASS LEVER WITH WORKING LOCKING CATCH THAT GIVES A FEELING OF ACTION, WITH SOLIDITY & PURPOSE REMINISCENT OF THE REAL THING. ADDED DETAIL PARTS ARE SUPPLIED WITH EVERY COBALT-S.

**INCREDIBLE VERSATILITY:**  
COBALT S CAN LITERALLY SWITCH ANY ELECTRICAL ITEM CREATED FOR USE ON A MODEL RAILWAY, WITHOUT EXCEPTION... YET IT IS EASY TO WIRE & UNDERSTAND.

COBALT-S LEVERS CAN EASILY BE GROUPED TOGETHER JUST LIKE THE PROTOTYPE BUT THEY ALSO COME COMPLETE WITH A SUBTLE "ADDED SPACER" FOR THOSE WITH LARGER FINGERS.

**THERE ARE SIMPLY NO LIMITS:**  
YOU CAN CREATE A LOCAL SIGNAL BOX OR RE-CREATE THE CLASSIC MAJOR SIGNAL BOX OF A LARGE YARD OR CITY STATION.

IT'S ALL UP TO YOU.

### Cobalt-S solves problems:

With Cobalt-S, there is no need to add extra switches or expensive add-ons to make things work as you want because every Cobalt-S Lever has two on-on type changeover switches plus one "momentary" changeover switch already built in!

This makes Cobalt-S the one and only device that will operate any form of point or turnout control device or signal.

What's more, it will do that while simultaneously controlling interlocking, operate lights on a control panel and, where needed, provide power control for live frog point-work too.

### Cobalt-S improves control:

Use a Cobalt-S to control solenoids, and common problems disappear.

Use Cobalt-S with Cobalt iP Digital or Cobalt Classic ip Digital or Cobalt Classic (they have additional switches too) & options for layout control will be almost infinite.

### Cobalt-S loves Cobalt Alpha!

Combine the very flexible connections of Cobalt-S with the abilities of the Cobalt Alpha AEU interface and many more things are possible...

Irrespective of whether you choose to drive your trains with DC or DCC, combining Cobalt-S & Alpha products such as Alpha AEU & Alpha Sniffer means that you will need fewer wires to connect things together... so whole control panels now connect to the layout with just a single cable!

### Cobalt-S adds pleasure!

Above all, Cobalt-S feels and looks right, so it is a product to be enjoyed by all!

Wiring is clearly laid out & we have created a simple PCB connection as the hub of your Cobalt-S wiring.

### Cobalt-S includes detail!

Details such as etched brass labels & cast metal lever-top covers are also provided so you can dress it up any way you want!

## SINGLES, SIX AND TWELVE PACKS...

LEVERS ARE RARELY USED ALONE, SO WE HAVE CREATED MULTI PACKS WITH PRICE SAVINGS.



SINGLE DCP-CBS

SIX PACK DCP-CBS6

TWELVE PACK DCP-CBS12

## ETCHED BRASS NUMBERS



DCP-CS99

ADDED ETCHED BRASS NUMBERS, 1-99

## COBALT-S ACCESSORIES



THE FITTING KIT  
THIS IS WHAT COMES WITH EACH LEVER

- Painting your Cobalt-S levers is easy to do as the antique finish makes a good undercoat.
- Mask carefully around the lever base, the lever top and the latching plate (pull handle)
  - Spray with an automotive-type spray enamel or airbrush.. or carefully with a brush
  - Remove masking and then polish the brass lever top areas with fine wet & dry paper.

## JUST LIKE THE REAL THING...

SEVERAL VERSIONS OF THE PROTOTYPE EXIST, BUT THIS IS REMARKABLY LIKE A COBALT-S FRAME!



**ST ALBANS SOUTH SIGNAL BOX**  
(With thanks to those who care  
enough to preserve our heritage)  
[www.sigbox.co.uk](http://www.sigbox.co.uk)

## ONE HALF OF A 52 LEVER FRAME, READY TO USE!

PAINTED, NUMBERED, ELECTRICALLY INTERLOCKED & READY FOR PROTOTYPICAL OPERATION.

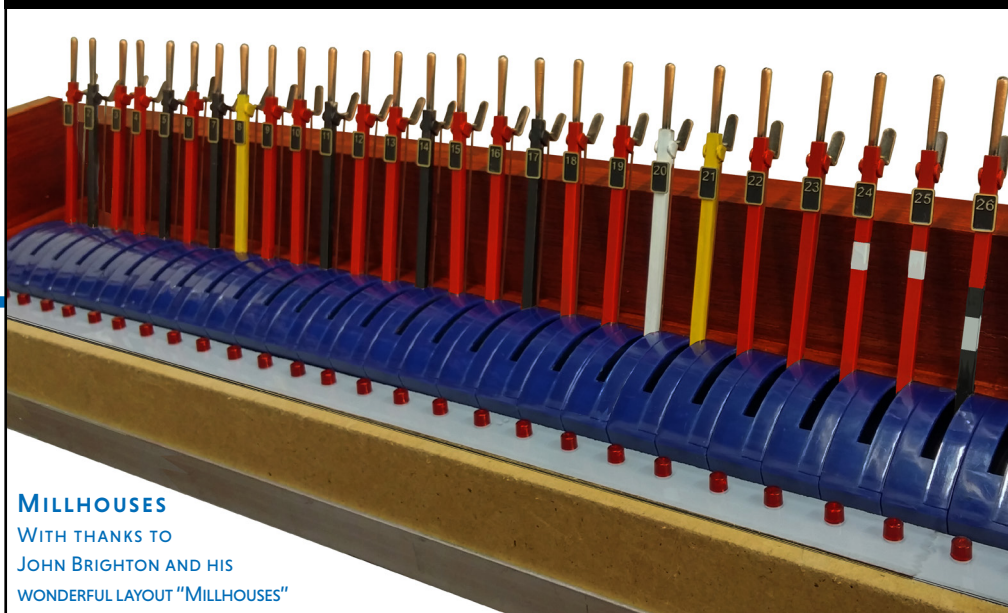

### MILLHOUSES

WITH THANKS TO  
JOHN BRIGHTON AND HIS  
WONDERFUL LAYOUT "MILLHOUSES"

## OPERATE LIKE THE REAL THING

### COBALT-S... A NEW WAY OF THINKING MAY RESULT!

When you make the decision to use Cobalt-S, it is also worth spending a little of your time researching on the web, visiting a preserved signal box and talking to the volunteers, or maybe buying a signalling book or two, because, apart from it being a more enjoyable way for you to change signals and turnouts, operating with levers may also bring a change to the way you think about layout control.

Levers are not worked like model railway "mimic panels". When you operate like the real thing does, turnouts are no longer set left and right, but "Normal or Reversed" and they are always returned to the "Normal" position after the train passes.

Levers in the signal box are always off or away from you when they are not needed to accommodate the needs of trains within their control area. This will set pointwork and related devices to a "default to safe" position. (This is a good practice for model trains too)

You never know: once you use levers, signals may also become more important to you, and things like sequence of action and lever movement may well take on a new meaning.

Whatever you do though, please enjoy the process of adopting Cobalt-S levers because our great hobby should always bring a smile to everything we do!

(If you need advice, email us: we will either help or refer you to someone who can)

WITH COBALT-S AND ALPHA, YOU CAN HAVE THE BEST OF BOTH WORLDS...

IF YOU INTERFACE COBALT-S TO YOUR LAYOUT VIA ALPHA AEU AND ALPHA MIMIC, YOU'LL NEED ONLY ONE SET OF CONTACTS FOR ALL CONTROL OF TURNOUTS AND ANY ASSOCIATED MIMIC PANEL LIGHTS.

THIS LEAVES COBALT-S CONTACTS FREE TO CONTROL DEAD SECTIONS AT THE FROG OF THE TURNOUTS THAT COBALT-S CONTROLS, MAKING IT IMPOSSIBLE TO OVER-RUN A POINT SET AGAINST THE TRAIN.

ALTERNATELY YOU CAN CONTROL CONNECTION TO OTHER LEVERS OR TO TRIGGER A BUZZER OR SIMILAR TO WARN YOU THAT A LEVER BEING MOVED IS "INTERLOCKED" WITH ANOTHER LEVER THAT MUST ALSO BE THROWN TO MAKE THE ROUTE COMPLETE. WITH IMAGINATION, THE POSSIBILITIES ARE ENDLESS.



## COBALT-S LEVER USERS MAY NEED A BOX DIAGRAM

ALPHA MIMIC IS THE PERFECT COMPANION FOR COBALT-S - IT NEEDS ONLY ONE PAIR OF WIRES TO THE LAYOUT

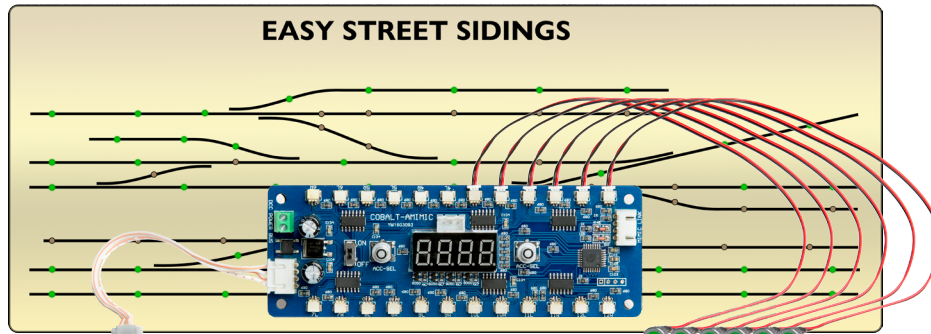

DCD-MPRD (RED)    DCD-MPGN (GREEN)    DCD-MPRG (RED AND GREEN)  
 NEW COLOURS COMING SOON ~ DCD-MPBL (BLUE)    DCD-MPRW (RED AND WARM WHITE)

ALPHA MIMIC IS TOTALLY PLUG AND PLAY WITH NO SOLDERING NEEDED. (SEE PAGE 34 FOR MORE DETAIL)

## REDUCING THE WIRES BETWEEN LEVERS & LAYOUT

CONNECT COBALT-S TO THE LAYOUT VIA ALPHA AEU AND YOU WILL NEED ONLY ONE 6-WIRE CABLE!

### THE ALPHA AEU

EACH ALPHA AEU CAN CONTROL 12 DEVICES.

SEVERAL AEUS CAN BE CONNECTED TOGETHER FOR LARGER LAYOUTS.

ALPHA AEU DIGITISES THE OUTPUT OF ANY FORM OF SWITCH AND REDUCES WIRING FROM PANEL TO LAYOUT TO A SINGLE 6-WIRE CABLE.

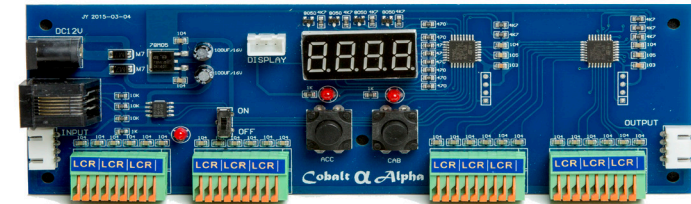

DCD-AEU

DCC COMPATIBLE - UNIVERSAL INTERFACE VIA ALPHA SNIFFER OR ADAPTERS

## EVEN EASIER COBALT-S CONNECTION

QUICK-CONNECT HARNESES WITH NO SOLDERING NEEDED

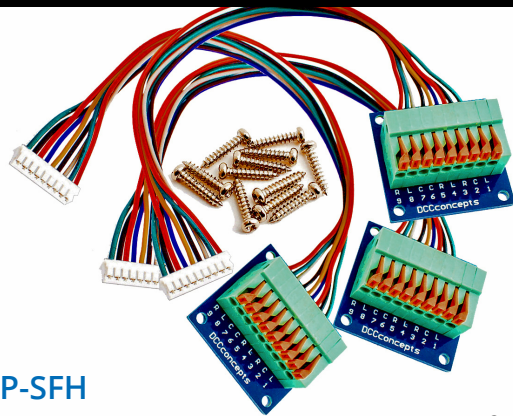

DCP-SFH

QUICK CONNECT HARNESS, AVAILABLE IN A PACK OF 3

## CONNECTIONS AND SETUP FOR COBALT-S

As with all of our products, we thought carefully about the connection and set-up requirements for Cobalt-S.

Everything is supplied in the pack, from a selection of etched brass numbers to fixing screws. The Cobalt-S Lever has a 9-wire JST socket, so the harness simply plugs in.

As supplied, the harness is already pre-stripped & tinned, making it easy to solder to the control PCB.

For those who dislike soldering or just want to make the connections even easier, we've made the DCP-SFH, which is a plug and play harness that has totally solder-free spring terminals for you to make connecting accessories easier.

Switching can be used in several ways. The two momentary contacts act at the end of throw (you will feel the positive spring pressure at throw end) and the two on-on switches have a clear make-before-break action so they can be used for any purpose you choose, digital or analog.

It's unusual to have a traditional item with such versatility!

## COBALT-S, ALPHA AEU & MIMIC

AN EXAMPLE WE CREATED TO SHOW YOU. ONE WIRE TO THE LAYOUT

LEVERS CONNECTED TO AN ALPHA AEU.

THE ALPHA AEU THEN CONNECTS TO THE LAYOUT WITH AN RJ12 CURLY CORD (6P6C) THAT PROVIDES POWER & COMMUNICATION

THE LEAD PART NUMBER IS DCP-ACL



AN ALPHA MIMIC DRIVES THE CONTROL PANEL LEDs IN THE DISPLAY. IT NEEDS ONLY 2 WIRES CONNECTED TO THE LAYOUT.

## COBALT-S HAS BOTH MOMENTARY AND ON-ON SWITCHES BUILT IN, SO IT WILL CONTROL EVERYTHING...

SOLENOIDS, COBALT, COBALT-SS AND OTHER MOTOR DRIVE TURNOUT MOTORS, SIGNALS OR ANYTHING ELSE YOU MIGHT IMAGINE, INCLUDING CROSSING GATES AND WORKING DETONATORS IF YOU ARE INTO FINE DETAIL!

# COBALT-S LEVERS CAN CONTROL & CONNECT TO ALMOST ANYTHING!

## THE COBALT-S LEVER ~ INSIDE AND OUT.

WITH THREE CHANGEOVER SWITCHES ONBOARD AND A CHOICE BETWEEN MOMENTARY AND ON-ON SWITCHES, COBALT-S CAN CONTROL ALMOST ANYTHING! THE MANUFACTURING QUALITY IS EXCEPTIONAL AND IT REALLY FEELS GOOD TO USE. WIRING CAN BE SIMPLE OR COMPLEX. THE CHOICE IS UP TO YOU!

A LEAD THAT PLUGS DIRECTLY INTO COBALT-S IS SUPPLIED IN THE PACK WHEN YOU BUY YOUR COBALT-S LEVER.

WE ALSO INCLUDE THIS PCB TO MAKE IT EASIER FOR YOU TO INTERFACE THE COBALT-S LEVER WITH YOUR LAYOUT WIRING.

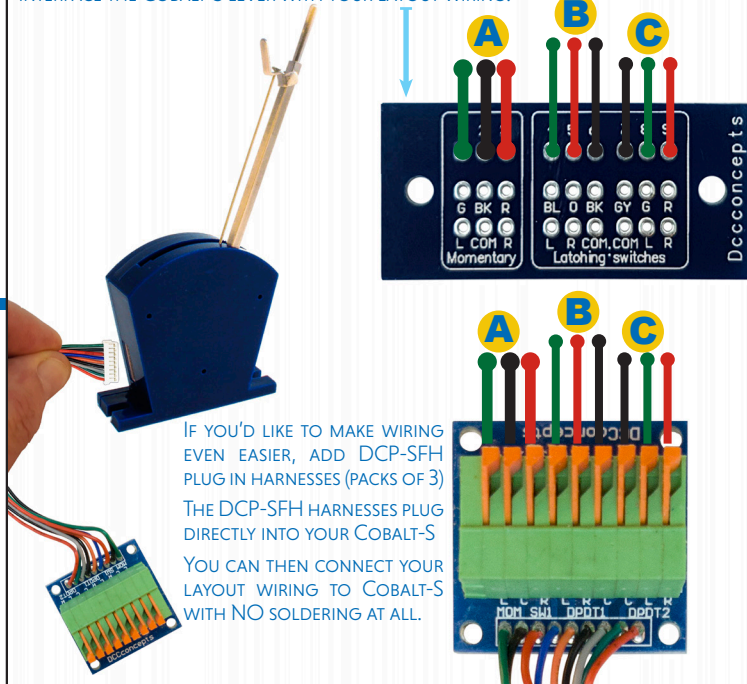

IF YOU'D LIKE TO MAKE WIRING EVEN EASIER, ADD DCP-SFH PLUG IN HARNESS (PACKS OF 3) THE DCP-SFH HARNESSES PLUG DIRECTLY INTO YOUR COBALT-S YOU CAN THEN CONNECT YOUR LAYOUT WIRING TO COBALT-S WITH NO SOLDERING AT ALL.

### COBALT-S CONNECTIONS

THERE ARE THREE SWITCHES ON EACH COBALT-S LEVER. ALL SWITCHES ARE MAKE-BEFORE-BREAK TO GIVE CLEAR AND ACCURATE RESPONSES WITHOUT THE ANNOYING MOMENTARY SHORTS THAT SOME SWITCHES CAN CREATE. ALL SWITCH CONTACTS ARE GOLD PLATED FOR RELIABILITY AND THEY ARE ALL ABLE TO HANDLE 5 AMPS OF LOAD

**A** THESE ARE THE MOMENTARY SWITCH CONNECTIONS.

CONTACT ORDER:  
LEFT - COMMON - RIGHT

ORDER MATCHES SOLENOIDS & ALPHA INTERFACE

**B** THESE ARE S.P.D.T. ON-ON TYPE SWITCH CONNECTIONS.

CONTACT ORDER:  
LEFT - RIGHT-COMMON

ORDER MATCHES COBALT IP ONBOARD SWITCHES

**C** THESE ARE S.P.D.T. ON-ON TYPE SWITCH CONNECTIONS.

CONTACT ORDER:  
COMMON - LEFT - RIGHT

ORDER MATCHES COBALT IP ONBOARD SWITCHES

### INSIDE COBALT-S

COBALT-S IS DESIGNED WITHOUT ANY COMPROMISES FOR A VERY LONG LIFE AND HIGH RELIABILITY. ALL CONTACTS ARE GOLD PLATED. THE LEVER ITSELF IS SOLID BRASS

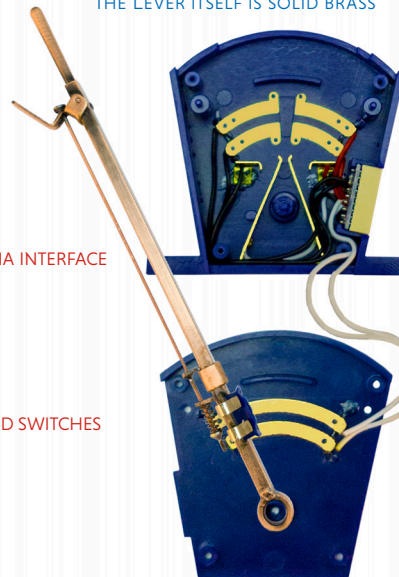

## COBALT-S IS THE ONLY SWITCHING DEVICE THAT REALLY CAN DO IT ALL!

COBALT-S REALLY CAN CONTROL ANY SORT OF ELECTRICAL DEVICE THAT YOU CONNECT TO YOUR LAYOUT. IT CAN DO IT VIA A DIGITAL INTERFACE OR WITH ALL STANDARD ANALOG WIRING APPROACHES. IT REALLY IS UP TO YOU!

AS 'SCISSORS CROSSING' WIRING IS A VERY COMMON "HELP" REQUEST, WE WILL SHOW YOU TWO EXAMPLES ON THESE PAGES:

### TOP RHS. IF CONTROLLED BY ALPHA.

ONLY THE WIRES USED FOR INTERLOCKING THE POINTS & ADDING FROG POWER ARE SHOWN IN THE DRAWING TO PREVENT CONFUSION.

(THE COBALT IP DIGITAL MOTORS WILL OF COURSE NEED TO BE CONNECTED TO THE TRACK OR ACCESSORY BUS FOR POWER)

THE MOTORS THEMSELVES NEED NO ADDED WIRING IF YOU CONTROL THEM WITH COBALT-S LEVERS OR IN FACT ANY TYPE OF SWITCH VIA THE DCCCONCEPTS ALPHA AEU.

### WHAT'S SURPRISING IS HOW SIMPLE IT IS!

(NOTE: IT IS EQUALLY EASY TO DO IT THIS WAY ON DC OR DCC LAYOUTS. DC MODELLERS NEED TO ADD A LOW COST DIGITAL ACCESSORY BUS BY USING AN "ALPHA SNIFFER".

### LOWER RHS. CONVENTIONAL CONTROL.

THIS USES COMMONLY USED SOLENOIDS WITH STANDARD DC WIRING AND OUR CDU-2.

IT NEEDS A LOT OF WIRES, BUT THE PRINCIPLES OF COBALT-S USE ARE EXACTLY THE SAME.

COMPLETE AND FULLY WIRED DIAGRAMS CAN BE FOUND IN THE HELP AREA OF OUR WEBSITE!

# INTERLOCKING & FROG CONTROL - A SCISSORS CROSSING - ALPHA, COBALT IP DIGITAL & COBALT-S LEVERS

FOR A FULLY DETAILED SET OF DIAGRAMS COVERING ALMOST ANY WIRING QUESTION IN RELATION TO TURNOUTS OR POINTWORK PLEASE VISIT THE MANUALS AND ADVICE PAGES OF OUR WEBSITE

Master for Crossover #1

TRACK AND MOTOR POWER CONNECTIONS ARE NOT SHOWN IN ORDER TO MAINTAIN DIAGRAM CLARITY

Master for Crossover #2

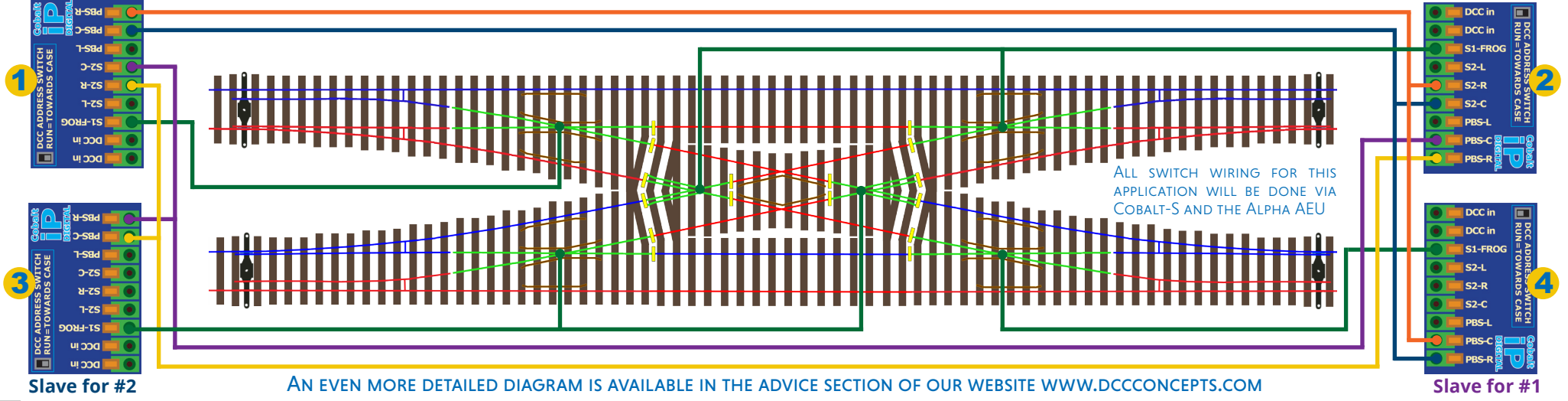

Slave for #2

Slave for #1

AN EVEN MORE DETAILED DIAGRAM IS AVAILABLE IN THE ADVICE SECTION OF OUR WEBSITE WWW.DCCCONCEPTS.COM

# CONTROLLING ANY LAYOUT ACCESSORY THAT NEEDS ONLY MOMENTARY POWER WITH COBALT-S LEVERS

SOLENOID CONTROL OF A SCISSORS CROSSING IS OK UNTIL YOU NEED TO INTERLOCK OR SWITCH THE FROGS - BUT IF YOU USE COBALT-S & ADD COBALT REX, ALL PROBLEMS ARE SOLVED!

TRACK POWER CONNECTIONS ARE NOT SHOWN IN ORDER TO MAINTAIN DIAGRAM CLARITY

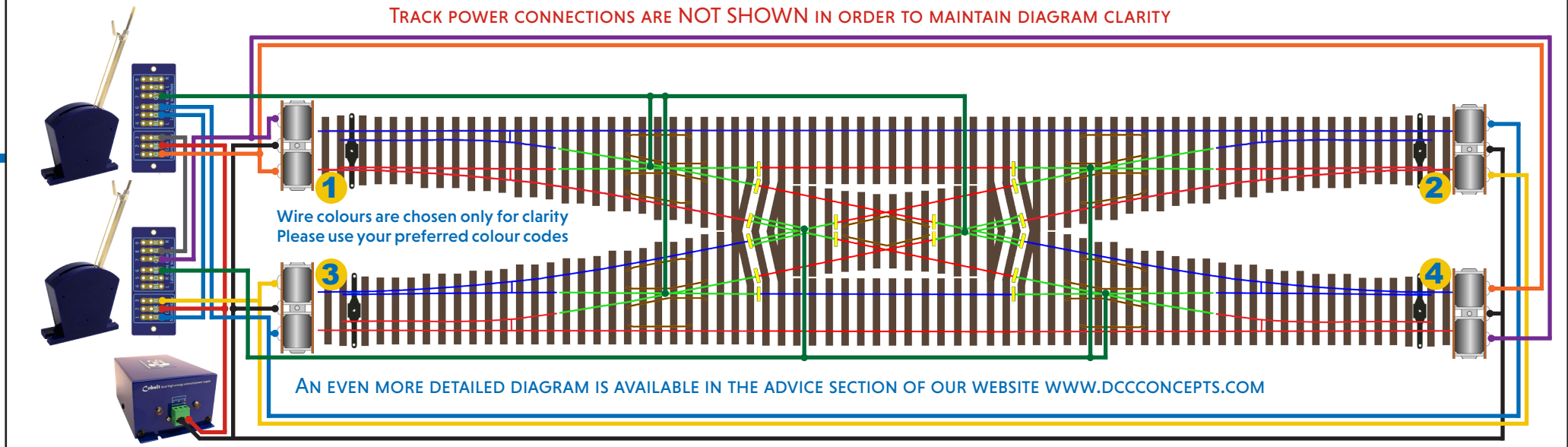

Wire colours are chosen only for clarity  
Please use your preferred colour codes

AN EVEN MORE DETAILED DIAGRAM IS AVAILABLE IN THE ADVICE SECTION OF OUR WEBSITE WWW.DCCCONCEPTS.COM

## COBALT REX - WHAT IT IS AND WHAT IT CAN DO.

AN OVERVIEW OF THE DCP-REX (COBALT REX): REX'S INPUTS, OUTPUTS & CONFIGURATION ABILITIES.

### RELAY "ACTION TYPE" FOR RELAY 1 AND 2

THIS CHANGES RELAYS FROM MOMENTARY CONTACTS (N.O. OPERATION) TO LATCHING CONTACTS (N.C. OR NORMALLY CLOSED)

SET TO NO-SW FOR MOMENTARY.  
SET TO NC-SW FOR LATCHING.

### POWER INPUT CONNECTION TERMINALS

NOMINALLY 9-21V. RECOMMENDED RANGE IS 12 TO 18 VOLTS DC OR DCC TRACK POWER

### REX CONFIGURATION SWITCH. SETS REX

RELAY OPERATION TO BE ALL AT ONCE OR WITH 1 + 2 AND 3 + 4 AS INDEPENDENT PAIRS  
UP= ALL 4 TOGETHER, DOWN= IN PAIRS

### REX TRIGGER (SWITCHING) TERMINALS.

THESE SET HOW REX REACTS TO INPUTS. YOU CAN USE A LEFT/RIGHT COMMON APPROACH OR COMMON + LEFT FOR 1 AND 2, PLUS COMMON + RIGHT FOR 3 AND 4. THIS INPUT CAN ACCEPT ANY FORM OF SWITCH AND IS OK TO USE WITH LOW VOLTAGE DETECTORS OR SIMPLE TRIGGERS SUCH AS REED SWITCHES

### RELAY "ACTION TYPE" FOR RELAY 3 AND 4

THIS CHANGES RELAYS FROM MOMENTARY CONTACTS (N.O. OPERATION) TO LATCHING CONTACTS (N.C. OR NORMALLY CLOSED)

SET TO NO-SW FOR MOMENTARY.  
SET TO NC-SW FOR LATCHING.

REX WORKS WITH ALL SWITCH TYPES & MANY KINDS OF DETECTOR OR AUTOMATION

- ANY TYPE OF MOMENTARY OR ON-ON SWITCH. JUST SET THE "ACTION TYPE" SWITCH.
- ALL KINDS OF MAGNETIC REED SWITCHES OR "HALL EFFECT" TRIGGERS.
- ALMOST ANY KIND OF DETECTOR CAN ALSO TRIGGER REX. JUST CONNECT YOUR DETECTOR OUTPUTS TO THE "TRIGGER" OR SWITCHING TERMINALS WITH A 1000-5000 OHM (1k-5k OHMS) RESISTOR PLACED IN SERIES WITH ONE OF THE OUTPUT WIRES OF YOUR DETECTOR.

(IF YOUR DETECTOR HAS A HIGHER (MORE THAN 5V DC) OUTPUT THEN A HIGHER VALUE RESISTOR MAY BE NEEDED. IF YOU ARE NOT SURE, START WITH 10,000 OHMS (10K OHMS) & EXPERIMENT)

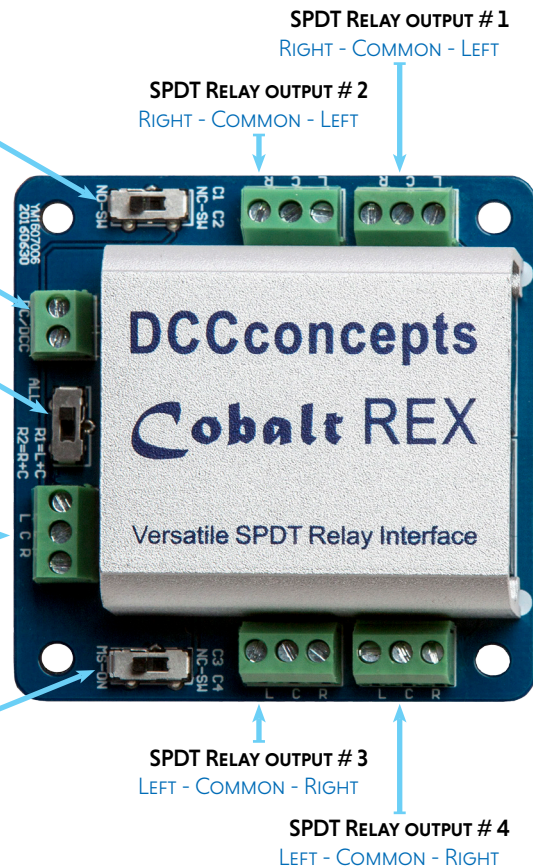

## ABOUT COBALT REX

### A VERY VERSATILE ADD-ON SWITCHING DEVICE!

When we create a product, we do our very best to make sure that it is equally usable by DC or DCC modellers.

We also add as much as we can so that you can be sure there's rarely other things you need to buy when using our products.

We try to give you real choice in operation as well. For example, DC or DCC, you can use many of our products with Alpha, digital control OR analog switching.

Finally, we try to think outside the box every time as we know that modellers are endlessly creative and, inevitably, they will always want just a little bit more.

So - "There is no point at all in doing it by halves" is always in

our thoughts when we design our new products, and REX is a result of that kind of thinking!

REX is a small, simple but clever add-on switching interface. It has been fitted with four high power S.P.D.T relays that can be ganged, or, if you wish, used as two separately switched pairs.

REX's control switches can be set any way that you want & can be configured to give almost any combination of results that we can think of!

So, with Cobalt REX, you will be able to control almost anything on your layout!

We use 12-18V DC but REX works well on all common DCC Track voltages.

- REX has 4 built-in relays and can change all of its contacts at once.
- REX can also act like a pair of independent devices. You can choose that option just by changing a control switch position.
- REX can be controlled by any kind of switch.
- REX has built in memory so it always remembers its state, last position and settings when power is off.
- REX is easy to connect as everything on the REX PCB is labelled clearly.
- REX is easy to set up just by moving its switches, and it uses very little power.

### PRODUCT RANGE:

### REX: DCCCONCEPTS COBALT RANGE ACCESSORIES

#### PRIMARY DESIGN GOALS:

Improve wiring versatility. Make it simpler for modellers to have both Cobalt-linked & automated, interactive switching

#### APPROPRIATE SCALE USE:

Usable with layouts of any prototype in all modelling scales

#### USER SKILL REQUIREMENT:

Low. Screw-terminals. Simple switch control. No programming

#### APPLICATION / SUITABILITY:

Suitable for DCC or DC use. High power contacts (max 5A)

#### SWITCHING INTERFACE:

Selectable. Switch or detector. Momentary or ON-ON

#### OTHER-BRAND INTERACTION:

Interfaces with most devices that can change a switch state

#### POWER REQUIREMENTS:

DC or DCC power. The range limits are 9-21V DC or DCC

# REX - CONNECTION EXAMPLES

## EXTEND & ENHANCE YOUR LAYOUT CONTROL

### AUTOMATING A DCC REVERSING LOOP

IF YOU CONNECT REX TO A SWITCH ON ANY COBALT POINT MOTOR, WHEN YOU CHANGE THE POINT (TURNOUT), LOOP POLARITY WILL ALSO CHANGE SO THAT IT MATCHES THE MAIN LINE.

AS YOU CAN SEE, THIS EXAMPLE STILL LEAVES YOU WITH HALF OF THE RELAY CONNECTIONS OF YOUR REX COMPLETELY FREE, SO YOU CAN USE THEM TO ADD LEDs, SIGNALS OR OTHER THINGS.

THIS EXAMPLE SHOWS THE WIRING CONNECTIONS FOR A DCC LAYOUT.

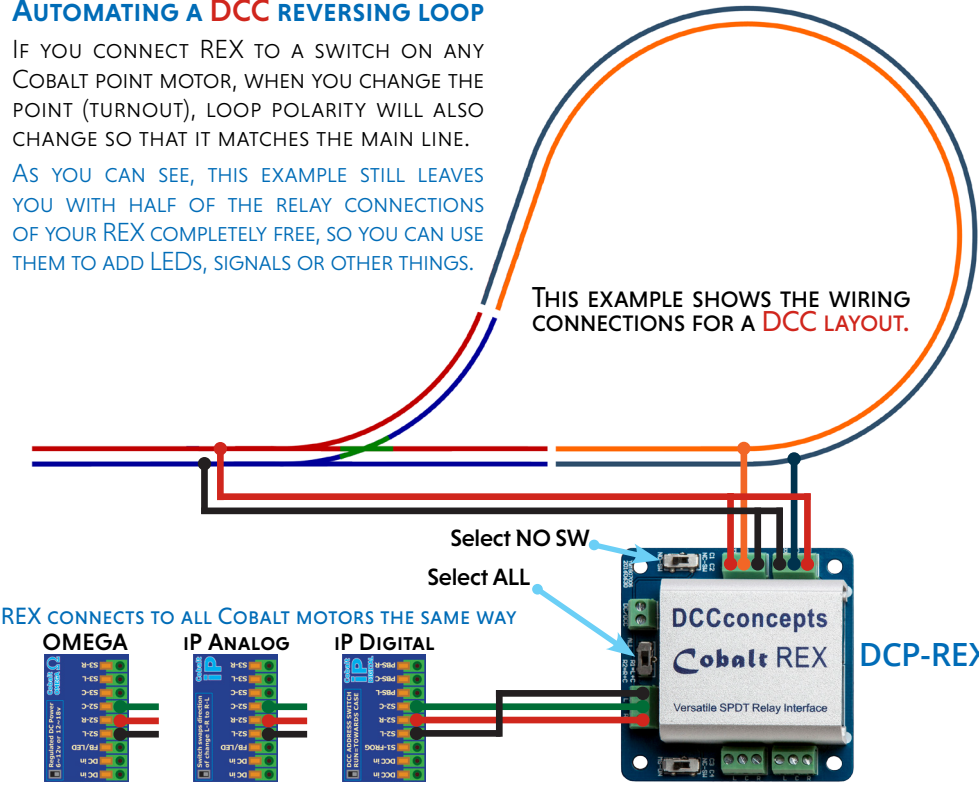

**COBALT REX - AN ECONOMICAL & FULLY AUTOMATED REVERSE LOOP FOR DCC**  
SIMPLE & EASY TO DO, ITS EVEN MORE GENTLE THAN STANDARD DCC REVERSERS AS THERE ARE NO SHORTS!

### COBALT REX - AN ECONOMICAL & FULLY AUTOMATED REVERSE LOOP FOR DC

USING COBALT REX LINKED TO COBALT IP OR OMEGA MOTORS TO CONTROL FROG POWER & REVERSE LOOPS

### AUTOMATING DC REVERSING LOOP

THIS EXAMPLE SHOWS THE WIRING CONNECTIONS FOR A DC LAYOUT.

THE DC CONTROLLER OUTPUTS GO DIRECTLY TO THE LOOP. THE REST OF THE LAYOUT IS POWERED VIA REX.

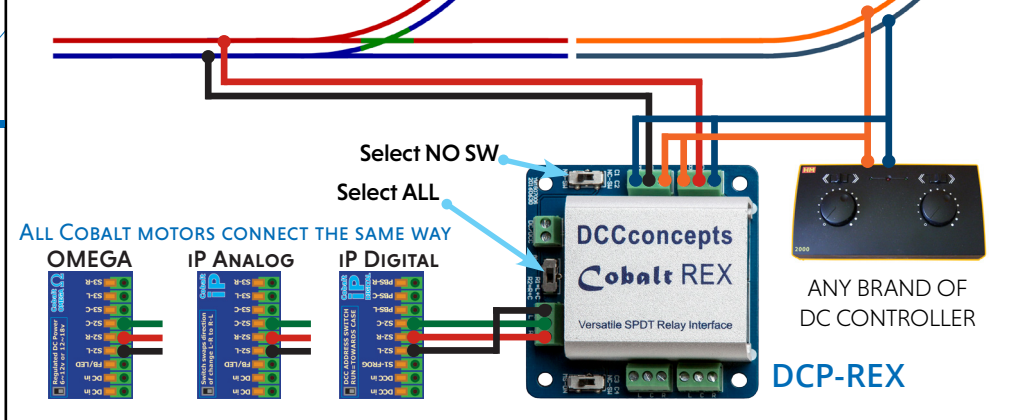

### Momentary switch or 2 pushbuttons

BECAUSE THE SWITCH ONLY CONNECTS TO ONE SIDE OF THE POWER CIRCUIT FOR THE SOLENOIDS, WE CAN SAFELY SHARE THESE CONTACTS TO SWITCH REX AT THE SAME TIME AS YOUR SOLENOID POINT MOTORS.

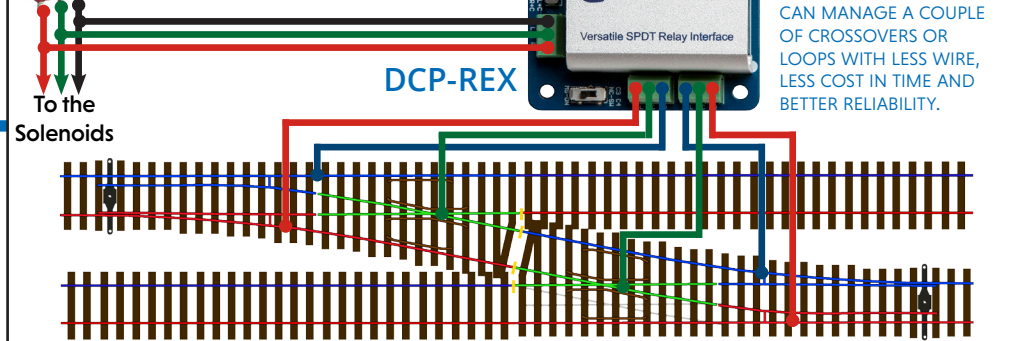

**REX & SOLENOIDS**  
SWITCHING FROGS DOES NOT NEED THE HASSLE OF INSTALLING FIDDLY MICRO-SWITCHES IF YOU HAVE REX. ONE REX CAN MANAGE A COUPLE OF CROSSOVERS OR LOOPS WITH LESS WIRE, LESS COST IN TIME AND BETTER RELIABILITY.

**COBALT REX - ECONOMICAL AND EASY FROG POWER CONTROL WITH SOLENOIDS**  
USING COBALT REX HERE WILL SAVE YOU TIME, MONEY, WIRE, SOLDERING AND IT'LL BE MORE RELIABLE TOO

**ADS-8SX SOLENOID DECODER WITH SEPARATE CDU ON EACH OUTPUT**  
**8 SOLENOID OUTPUTS CAPABLE OF POWERING TWO MOTORS. SIMPLE ADDRESSING. DC OR DCC**

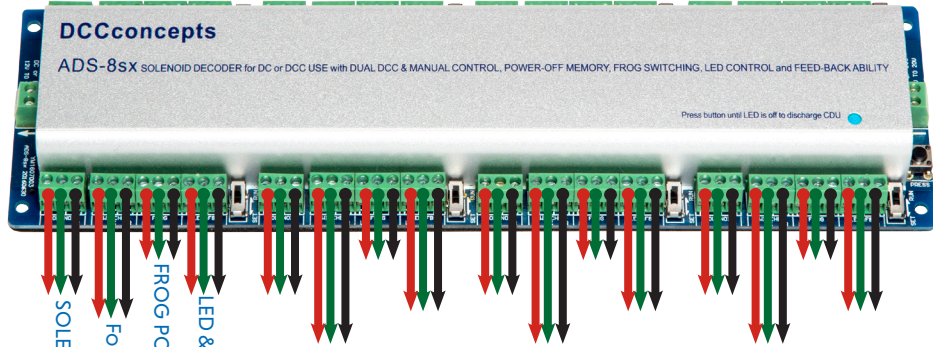

CHOOSING OUR ADS-8, ADS-2 OR AD-2 ACCESSORY DECODERS WILL ACTUALLY COST YOU LESS MONEY, NEED LESS WIRING OR SOLDERING AND NEED LESS TIME.

YOU'LL ALSO BE SAVED A LOT OF FRUSTRATION WITH NO NEED TO ADD OR ADJUST ANY HARD-TO-INSTALL MICRO-SWITCHES .

THEY ALL WORK EQUALLY WELL WITH DC (18V DC POWER) OR ON DCC LAYOUTS IN ALL SCALES.

SO... NO MATTER WHICH WAY YOU CHOOSE TO DRIVE YOUR TRAINS, YOU CAN STILL TAKE ADVANTAGE OF THEIR FEATURES AND BENEFITS!

THE ADS-2SX SOLENOID DECODER. 2 WAY, EACH WITH ITS OWN CDU POWER. BOTH OUTPUTS ARE ABLE TO DRIVE TWO MOTORS. SIMPLE ADDRESSING, DC OR DCC

THE AD-2SX (COBALT TYPE) "STALL MOTOR" DECODER  
 2 OUTPUTS WITH EACH ABLE TO POWER SEVERAL MOTORS. SIMPLE ADDRESSING. LOW POWER DRAW. DC OR DCC

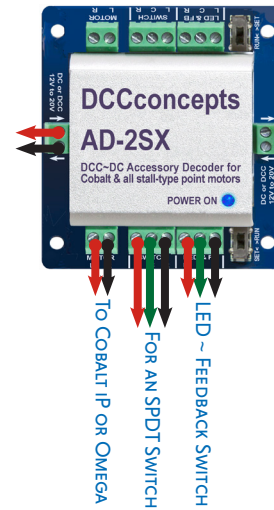

# COBALT AD & ADS SERIES DECODERS

**PRODUCT RANGE :**

- APPROPRIATE SCALE USE:
- CASE & LEVER MATERIAL:
- PCB & OTHER MATERIAL:
- PHYSICAL SIZE :
- POWER CONSUMPTION:
- ACCEPTABLE POWER USE:
- AVAILABLE PACK SIZES:

**DCCCONCEPTS COBALT ACCESSORY DECODERS**

T, Z, N, HO, OO, O, G, GAUGE 1 (OUTDOOR USE IS OK WITH CARE)  
 CUSTOM ALUMINIUM EXTRUSION, MILLED/PASSIVATED FOR LONG LIFE  
 PCB MADE FROM MIL SPEC FIBREGLASS. KEY CONTACTS GOLD PLATED  
 VARIES: COMMON WIDTH WITH STYLE-MATCHED COVER POSITION  
 POWER STORED ONBOARD. USE DOES NOT DRAIN THE TRACK POWER FOR DCC, ALL COMMON VOLTAGES. FOR DC, 18~21V ADVISED  
 INDIVIDUAL. CHOICE OF 8 OR 2 OUTPUTS FOR ADS MODELS

SETTING UP AN ACCESSORY DECODER ADDRESS IS EASILY DONE IN 3 SIMPLE STEPS.

**1**  
 INSTALL AND CONNECT AN AD OR ADS DECODER TO THE DCC POWER BUS.  
 MOVE THIS SWITCH TO THE "SET" POSITION



**2**  
 CHOOSE AN ADDRESS BETWEEN 1 & 2043.  
 USING THE DCC CONTROL SYSTEM, ACT AS IF YOU ARE ALREADY CHANGING THE POINT (TURNOUT) AT THE CHOSEN ADDRESS.  
 BECAUSE IT'S IN "SET" MODE, YOUR AD~ADS DECODER WILL LISTEN, LEARN, AND REMEMBER THE NUMBER YOU ENTERED AS ITS OWN ADDRESS FOR THE FUTURE.

**3**  
 RETURN THE SWITCH TO THE "RUN" POSITION.  
 NOW REPEAT STEP TWO. YOUR POINT (TURNOUT) WILL NOW RESPOND TO THE ADDRESS YOU USED.



**TIPS**  
 YOU CAN SET NUMBERS OR ADDRESSES OF 2 OR MORE OUTPUTS AT THE SAME TIME IF YOU WISH.  
 CROSSOVERS AND LOOPS CAN SHARE ONE OUTPUT IF THE FROG POLARITY IS THE SAME IN BOTH.  
 YOU CAN ALSO SET 2 OR MORE OF YOUR AD OR ADS DECODER OUTPUTS TO THE SAME ADDRESS SO THEY WILL ALWAYS CHANGE TOGETHER IF YOU WISH.

## THREE ACCESSORY DECODERS THAT DO IT ALL...

INCREDIBLY, ON DC OR DCC LAYOUTS, THEY WILL ALSO COST YOU LESS MONEY, TIME AND EFFORT THAN IF YOU WERE USING CONVENTIONAL ANALOG CONTROL WITH THE EQUIVALENT SWITCHING AND CDU POWER!

# EASY TO USE, WITH FEWER COMPLICATIONS

## THE BEST AVAILABLE?

### COBALT SX SERIES DECODERS

WE DESIGNED THIS RANGE FROM THE GROUND UP TO MAKE THINGS BETTER - AND MUCH EASIER!

### WHY DID WE NEED TO DO IT?

FROM THE VERY START, MOST DCC ACCESSORY DECODERS HAVE NOT BEEN ABLE TO RELIABLY DRIVE MANY OF THE SOLENOIDS SOLD BY MAJOR TRACK BRANDS AND NONE OF THEM COULD CHANGE A PAIR OF POINTS IN A CROSSOVER OR A LOOP RELIABLY, MAKING DCC ACCESSORY CONTROL EXPENSIVE AND OFTEN QUITE FRUSTRATING. EVEN NOW... MOST DO NOT HAVE THE ABILITY TO GIVE YOU CONTROL PANEL FEEDBACK, CAN'T CONTROL THE FROG POLARITY OR DO MUCH AT ALL, SO MODELLERS HAVE THE ADDED LOAD OF NEEDING TO ADD OTHER THINGS, CREATING MORE COST, TIME AND WASTED EFFORT...

### OUR COBALT SX DECODERS:

ALL OF OUR ACCESSORY DECODERS WILL DRIVE A FULL CROSSOVER, SWITCH POINT FROGS, PROVIDE THE CONNECTIONS FOR CONTROL PANEL LEDs, COMPUTER IO OR FEEDBACK & GENERALLY DO IT ALL.

THEY EVEN WORK ON DC OR DCC

## LINKING AD OR ADS TO ALPHA (AND MAKING YOUR WIRING EVEN SIMPLER)

THE DIAGRAM TO THE RIGHT SHOWS THE FEATURES AND ABILITIES OF AN ADS OR AD SERIES DECODER.

EVEN THOUGH THEY ARE EASIER TO INSTALL AND WIRE THAN OTHER BRANDS, THERE'S STILL A LOT OF WIRE!

HERE IS WHAT HAPPENS IF WE ADD AN ALPHA AEU OR ALPHA CENTRAL UNIT. (ALPHA CENTRAL IS SHOWN HERE).

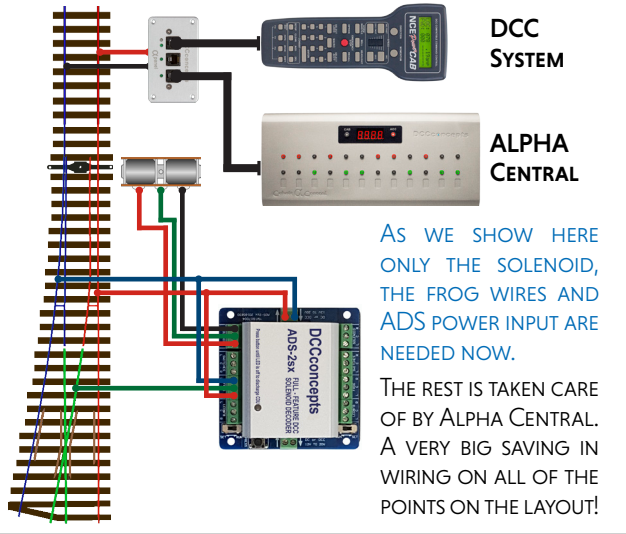

AS WE SHOW HERE ONLY THE SOLENOID, THE FROG WIRES AND ADS POWER INPUT ARE NEEDED NOW. THE REST IS TAKEN CARE OF BY ALPHA CENTRAL. A VERY BIG SAVING IN WIRING ON ALL OF THE POINTS ON THE LAYOUT!

## ADS DECODERS: DESIGNED FOR TOTAL FLEXIBILITY, BUT KEEPING IT SIMPLE & SO EASY TO DO

A CLOSER LOOK AT THE ABILITIES OF OUR ADS SOLENOID DECODERS, THE ADS FEATURES AND THEIR WIRING

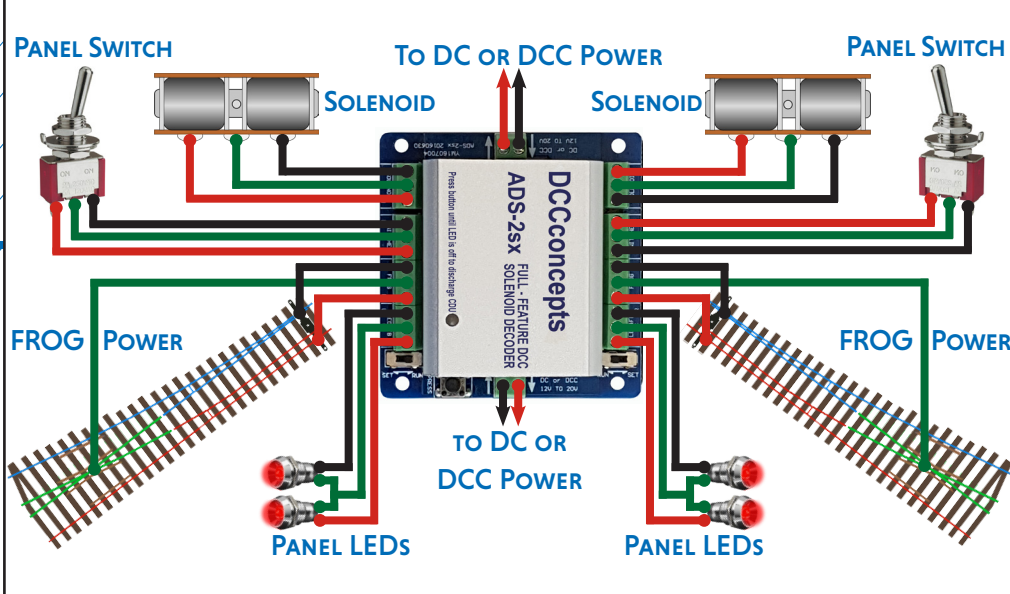

## CONTROLLING COBALT

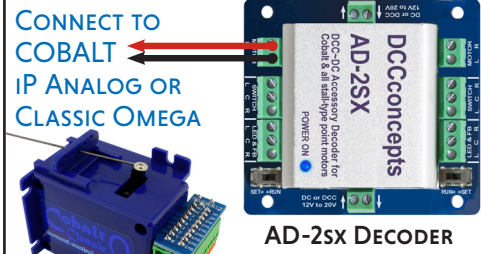

AN AD-2SX CAN MANAGE TWO OR MORE COBALT IP ANALOG OR CLASSIC MOTORS ON EACH OUTPUT

## CONTROLLING KATO

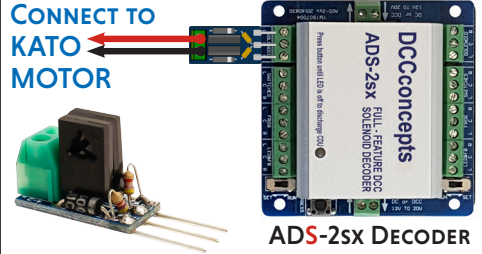

DCD-SDC KATO ADAPTERS AVAILABLE IN PACKS OF 3, 6 OR 12. SUITABLE FOR ANY 2-WIRE SOLENOID.

THE BUTTON AND THE BLUE LED ON EVERY ADS-2sx AND ADS-8sx DECODER WHEN THE BLUE LED IS LIT, ALL OF THE CDUs ARE FULLY CHARGED, EVEN WITH POWER OFF. THEY MUST BE DISCHARGED BEFORE MAKING OR BREAKING CONNECTIONS OR WIRING TO AVOID DAMAGE. THERE IS A BUTTON SWITCH AT THE END OF THE DECODER... HOLD IT DOWN UNTIL THE LED IS OFF!

# ALPHA AEU - THE HEART OF COBALT ALPHA

ALPHA AEU CONVERTS SWITCH OUTPUTS TO DIGITAL COMMANDS. SAY GOODBYE TO ALL THOSE WIRES!

DCD-AEU



THE ALPHA AEU  
EACH ALPHA AEU CAN  
CONTROL 12 DEVICES.  
MANY ALPHA AEU UNITS  
CAN BE USED TOGETHER  
FOR LARGER LAYOUTS.  
ALPHA AEU DIGITISES  
THE OUTPUTS OF ANY  
FORM OF SWITCH AND  
IT CONNECTS TO YOUR  
LAYOUT WITH A SINGLE  
6-WIRE CABLE.

# COBALT ALPHA CENTRAL & AEU

FORGET THE TECHNICAL STUFF, ENJOY THE BENEFITS!

**Cobalt Alpha was created to answer a simple question... "If I am using digital, why do I need all those wires?"**

It was a very good question asked by a client who was also able to do a neat and tidy job of wiring his layout, but did not enjoy doing it..

He was right of course, and when we considered it, it was clear that there was a very big hole in the whole railway "layout control story".

Existing digital control gear tries hard to add features but all of them need multi-step access to control accessories.

This really ignores two issues that are quite obvious from our ongoing investigations:

\* DCC layout control is clumsy!

Modellers, DC and DCC, also including those with tablet or screen based Digital control products, want much more than fine control of locos.

They want their accessory control to be up front and direct without the need to distract attention from train control - and most are much happier when operating with a physical track display and a simple to understand mimic panel for their accessories.

\* Traditional control panels are too complex to make!

And... to create any form of real world-like layout control requires hundreds of wires, lots of soldering plus the skill and patience to add many small added accessories to give proper point or turnout control plus panel indication of their state or position.

Cobalt Alpha, Alpha Mimic and related products are the simple and direct answer.

We will show you here how Alpha can fix both problems in an easy-to-do manner...

**For BOTH DC & DCC users...**

DCD-AEC

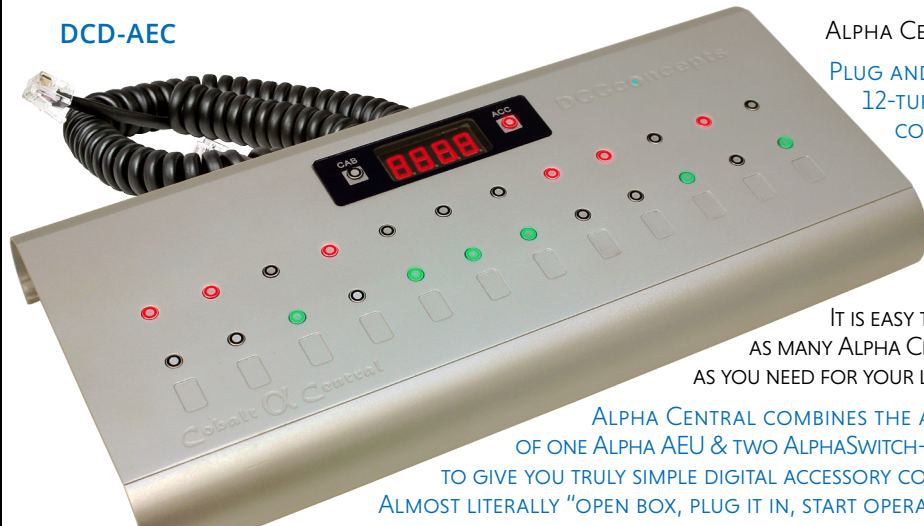

ALPHA CENTRAL  
PLUG AND PLAY  
12-TURNOUT  
CONTROL

IT IS EASY TO LINK  
AS MANY ALPHA CENTRAL  
AS YOU NEED FOR YOUR LAYOUT

ALPHA CENTRAL COMBINES THE ABILITY  
OF ONE ALPHA AEU & TWO ALPHASWITCH-D SETS  
TO GIVE YOU TRULY SIMPLE DIGITAL ACCESSORY CONTROL  
ALMOST LITERALLY "OPEN BOX, PLUG IT IN, START OPERATING"!

**ALPHA CENTRAL. OPEN THE BOX, PLUG IT IN AND CHANGE THE POINTS!**  
SMART AND EASY TO USE, ALPHA CENTRAL INTEGRATES ALPHA AEU & ALPHASWITCH-D

PRODUCT RANGE :		THE DCCONCEPTS COBALT ALPHA FAMILY
PRIMARY DESIGN GOALS:	SIMPLIFY LAYOUT CONTROL. REDUCE COMPLICATION. SEPARATE LAYOUT CONTROL FROM TRAIN CONTROL. UNIVERSAL USABILITY	
APPROPRIATE SCALE USE:	USABLE WITH LAYOUTS OF ANY PROTOTYPE IN ALL MODEL SCALES	
USER SKILL REQUIREMENT:	LOW - PLUG IN/BASIC WIRING. NO SOLDERING. NO PROGRAMMING	
APPLICATION / SUITABILITY:	SUITABLE FOR DCC OR DC USERS. (ADAPTERS MAY BE REQUIRED)	
SWITCHING INTERFACE:	ALPHASWITCH-D, COBALT-S & ALL ANALOG SWITCH TYPES	
OTHER-BRAND INTERACTION:	INTERFACES WITH MOST SCREEN BASED SYSTEMS VIA ALPHA SNIFFER	
POWER REQUIREMENTS:	DC / DCC POWER. NOMINALLY 18V DC, SAFE RANGE 9~21V DC	



# COBALT ALPHA POWER & BOX

## ADD POWER & UPGRADE DCC PERFORMANCE

ALPHA POWER IS A WELL REGULATED INTELLIGENT POWER SUPPLY WITH EXCELLENT PROTECTION MATCHING OTHER ALPHA RANGE PRODUCTS, THE ALPHA POWER HAS BOTH AN ALPHA TYPE DC BARREL PLUG OUTPUT (LEAD SUPPLIED) AND SCREW TERMINAL CONNECTIONS TO ADD VERSATILITY ALPHA POWER HAS BEEN TESTED TO WELL BEYOND ANY POSSIBLE USER LOAD TO ENSURE RELIABILITY THE INTERACTIVE OVERLOAD PROTECTION HAS BOTH AUDIBLE AND VISUAL WARNING OF HIGH POWER USE. AN EXCEPTIONALLY STABLE POWER SUPPLY ALSO SUITABLE FOR USE WITH DCC SYSTEMS OF MANY BRANDS



### DCD-PWR

THE HIGHEST QUALITY POWER SUPPLY MADE FOR THE HOBBY!  
 VERY STABLE AT 18V DC, 5A.  
 OVERLOAD PROTECTION WITH LED AND AUDIBLE WARNING.

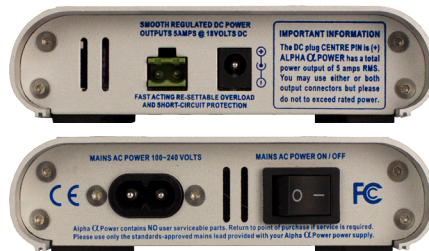

**ALPHA POWER** THE IDEAL POWER SUPPLY FOR MOST MODEL RAILWAYS  
 USABLE WORLD-WIDE, ALPHA POWER HAS A TIGHTLY REGULATED 18V DC OUTPUT PERFECT FOR ALL SYSTEMS

# ALPHA BOX - ADD POWER & ACCESSORY CONTROL

ALPHA BOX CAN ADD ACCESSORY CONTROL TO BASIC SYSTEMS, BOOST TRACK POWER AND MUCH MORE!

### DCD-AUX

ALPHA BOX IS A 5 AMP INTELLIGENT POWER BOOSTER WITH A DIRECT PLUG INTERFACE FOR COBALT ALPHA CENTRAL OR AEU

THIS INTERFACE OVERLAYS ALPHA INTELLIGENCE ONTO THE BUS. IT THEN COMBINES IT WITH YOUR DCC SYSTEM TRACK & COMMAND OUTPUTS.

THIS MAKES ALPHA BOX THE PERFECT WAY TO UPGRADE LOW POWERED START SETS TO A FULL 5 AMP OUTPUT AS IT WILL GREATLY IMPROVE OVERALL PERFORMANCE WHILE ADDING THE HUGE BENEFITS OF FULL DCC DIGITAL ACCESSORY CONTROL AND COBALT ALPHA.

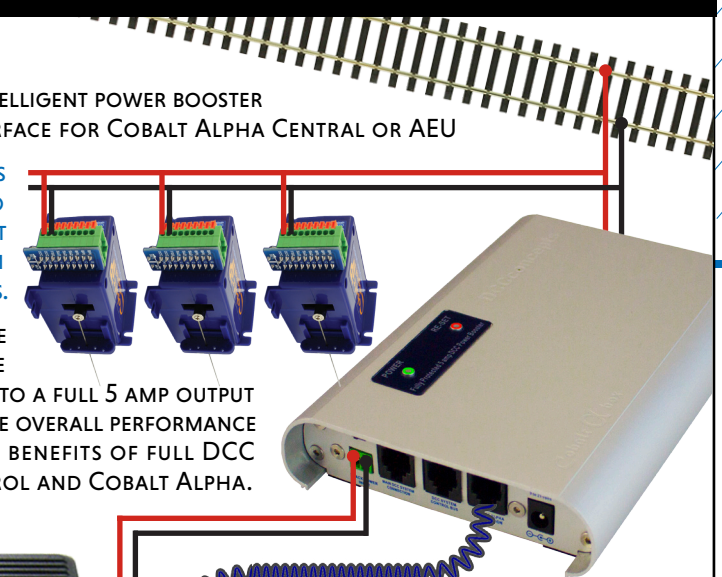

Alpha Box connections... ready to work with almost anything!



ALPHA BOX IS A TOP QUALITY 5 AMP POWER BOOSTER WITH "ALPHA INTELLIGENCE" BUILT IN.

THE WIDE RANGE OF CONNECTIONS, SUPPLEMENTED BY THE ABILITY TO ACCEPT DIRECT TRACK POWER INPUTS AND A RANGE OF ADAPTER LEADS THAT ALLOW DIRECT CONNECTION OF MANY COMMON DCC BRANDS MAKES IT UNIQUELY SUITABLE AS AN EASY AND DIRECT "ALPHA UPGRADE" FOR YOUR LAYOUT.

ALPHA BOX ALSO MAKES IT EASY TO UPGRADE "STARTER DCC SETS" TO FULL ACCESSORY CONTROL.

ALPHA BOX & ALPHA POWER ARE A CLEVER & POWERFUL PAIR THAT REPRESENT EXCELLENT VALUE!

# ALPHA SNIFFER - INTEGRATING ALPHA + ECOS OR Z21

A SIMPLE WAY TO INTEGRATE ALPHA & HAVE ITS COMMANDS REFLECTED PERFECTLY ON YOUR SCREEN



# THE CLEVER COBALT ALPHA SNIFFER

## INTEGRATING ALPHA WITH ALMOST ANYTHING AT ALL!

### MAKING IT EASIER & ENSURING IT'S SIMPLE TO WIRE

THE DCD-SNX ALPHA SNIFFER IS A SMALL, ECONOMICAL & VERY VERSATILE PART OF THE ALPHA RANGE. AS THE NAME IMPLIES, AS ONE OF ITS TALENTS IT IS AN EXCELLENT "SNIFFER" INTERFACE FOR CONTROL SYSTEMS SUCH AS ESU ECOS AND ROCO Z21. (ADDITIONALLY, SOMETIMES SNIFFER PORTS ARE A LITTLE WIRING SENSITIVE AND DCCCONCEPTS ALPHA SNIFFER HELPS TO GIVE THEM BETTER "SNIFFER" STABILITY TOO). OF COURSE, MANY USERS OF THESE SYSTEMS ALSO WANT A REAL-WORLD CONTROL PANEL BUT UNTIL NOW, IT'S BEEN HARD TO DO IT - AND STILL MAKE SURE THAT ECOS & Z21 SEE THE COMMANDS MADE - HOWEVER IF YOU LINK COBALT ALPHA CONTROL PANELS VIA THE SNIFFER, ANY COMMAND TRANSMITTED IS ALSO SEEN ON-SCREEN. MOST IMPORTANTLY, ALPHA SNIFFER PROVIDES A SIMPLE, LOW COST WAY FOR BOTH DC AND DCC MODELLERS TO CREATE A TOTALLY INDEPENDENT DIGITAL ALPHA-CONTROL POWER BUS, SO TRAINS CAN BE DRIVEN VIA DC OR DCC - BUT ACCESSORY CONTROL IS IMPROVED & OVERALL WIRING NEEDS ARE GREATLY REDUCED & SIMPLIFIED. THE PERFECT PRODUCT FOR THOSE OF US WHO JUST WANT TO GET ON WITH DRIVING THE TRAINS!

### ALPHA SNIFFER-VERY EASY WIRING FOR DC MODELLERS TOO!

CREATE A SEPARATE DIGITAL ACCESSORY POWER BUS BUT KEEP DRIVING YOUR TRAINS WITH DC IF YOU PREFER

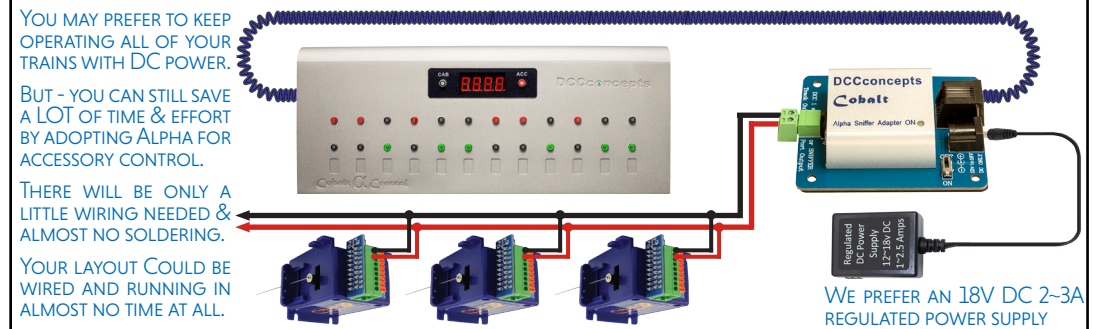

## ALPHASWITCH D SWITCH SYSTEM

CONTROL BOARD AND 12 SWITCHES WITH PLUG-N-PLAY WIRING

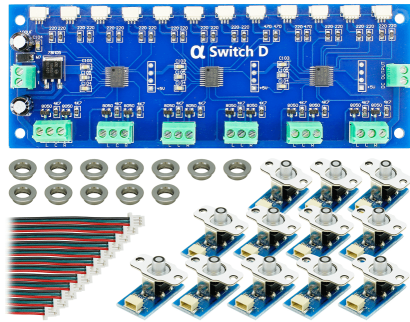

- DCD-DSR (Red Switches)
- DCD-DSG (Green Switches)
- DCD-DSB (Blue Switches)

## ALPHA ACCESSORIES

(ADAPTERS & LEAD RANGE ON PAGE 38)

## ALPHASWITCH A

LONG LIFE IS ASSURED WITH LIFE-TESTING FOR EVERY BATCH!

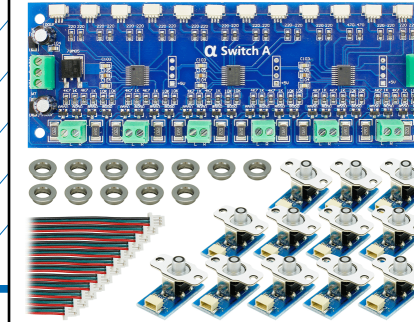

- DCD-ASR (Red Switches)
- DCD-ASG (Green Switches)
- DCD-ASB (Blue Switches)

## ALPHASWITCH D ADD-ON SWITCH

12 ADDITIONAL SWITCHES WITH PLUG-N-PLAY WIRING AND BEZELS

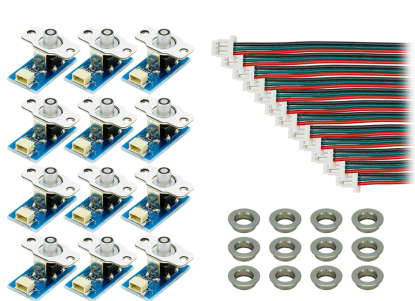

- DCD-ATR (Red Switches)
- DCD-ATG (Green Switches)
- DCD-ATB (Blue Switches)

## THE HEART OF ALPHASWITCH

A TOP QUALITY TACT SWITCH THAT LOOKS GREAT IN CONTROL PANELS

THIS IS THE ALPHASWITCH THAT IS IN ALL OF THE PACKS ON THIS PAGE. EASY TO INSTALL, IT IS SUPPLIED WITH A TURNED AND ANODISED ALLOY BEZEL FOR PERFECT PRESENTATION ON YOUR LAYOUT CONTROL PANELS.

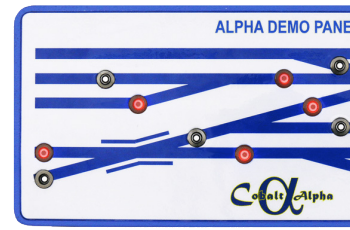
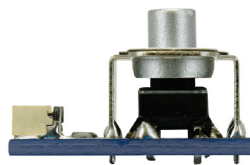

## POWER FOR ALPHASWITCH A

A NEAT & EFFICIENT WAY TO POWER COBALT IP ANALOG & OMEGA

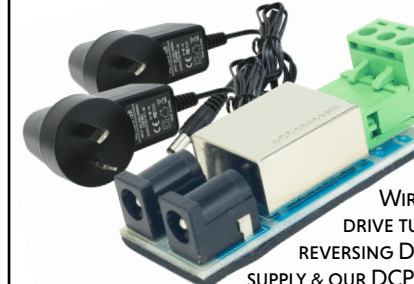

### DCP-SPS12

GLOBAL USE WITH 110-250V AC POWER. OUTPUT IS +/- 12V DC

WIRING COBALT OR ANY MOTOR DRIVE TURNOUT MOTOR THAT NEEDS REVERSING DC POWER WITH THIS POWER SUPPLY & OUR DCP-CBSXX SWITCH PACKS WILL GREATLY SIMPLIFY ANALOG CONTROL AND REDUCE WIRING COMPLEXITY

## ALPHA RANGE BRAND ADAPTERS

ONE BASE STATION ADAPTER & TWO HANDSET ADAPTERS IN EACH

- DCD-DTX (Digitrax)
- DCD-GMX (Gaugemaster)
- DCD-LZX (Lenz)



NCE and ROCO do not need adapters

VARIOUS DCC BRANDS CHOOSE DIFFERENT CONNECTORS, SO ADAPTERS MAY BE NEEDED. ALL ADAPTERS ARE CLEARLY LABELLED. THE COMMAND STATION LEAD IS ALWAYS LONGER.

## ALPHASWITCH WYE (Y) ADAPTERS

WYE OR PARALLEL CONNECTION OF SWITCHES - MADE EASY

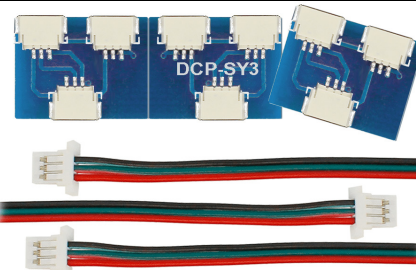

### DCD-SY3

IN PACKS OF 3 AS AN EASY "SNAP OFF PCB" (WITH 3X PLUG AND PLAY LEADS)

AN SY3 ADAPTER CAN BE USED TO MAKE ONE SWITCH WORK TWO DEVICES. OR USE IT TO LINK TWO SWITCHES ONTO ONE DEVICE.

MORE ALPHA ADAPTERS ON P 38

## ALPHASWITCH SOLENOID ADAPTER

FOR DIRECT CONTROL OF ADS SOLENOIDS BY ALPHASWITCH D

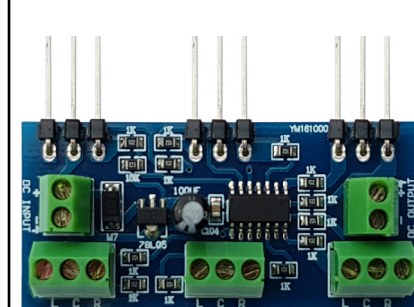

### DCD-DSS.2

SIMPLY INSERT THE PINS INTO THE OUTPUTS OF ALPHASWITCH-D AND USE THE EASY SCREW CONNECTIONS TO LINK THEM TO YOUR ADS-2 OR ADS-8 DECODER. IN A PACK OF TWO PCS.

# BRINGING ACCESSORIES UNDER CONTROL WITHOUT ANY COMPLICATION

RESTORING REAL-WORLD CONTROL WHILE MAKING WIRING MUCH SIMPLER WITH ALPHA AEU, ALPHA CENTRAL & ALPHA SNIFFER



CONNECT US TO ALPHA VIA THE ALPHA SNIFFER

ADD MORE POWER AND ACCESSORY CONTROL TO ANY BRAND, START SET ETC, BY CONNECTING VIA ALPHA BOX

CONNECT NCE DIRECTLY

ADD A DIGITAL ACCESSORY BUS TO A DC LAYOUT

← YOU WILL NEED ONLY ONE CABLE TO CONNECT THE PANEL AND THE LAYOUT

## DCD-AEU

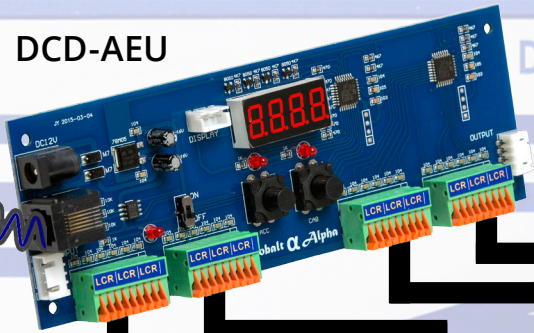

CONNECT ANY SWITCH TO ALPHA AEU AND IT INSTANTLY BECOMES A "DIGITAL SWITCH".

THE PANELS BELOW USE THE FOLLOWING:

- \* PUSHBUTTON SWITCHES
- \* ALPHASWITCH-D
- \* COBALT-S LEVERS
- \* SIMPLE STUD & PROBE

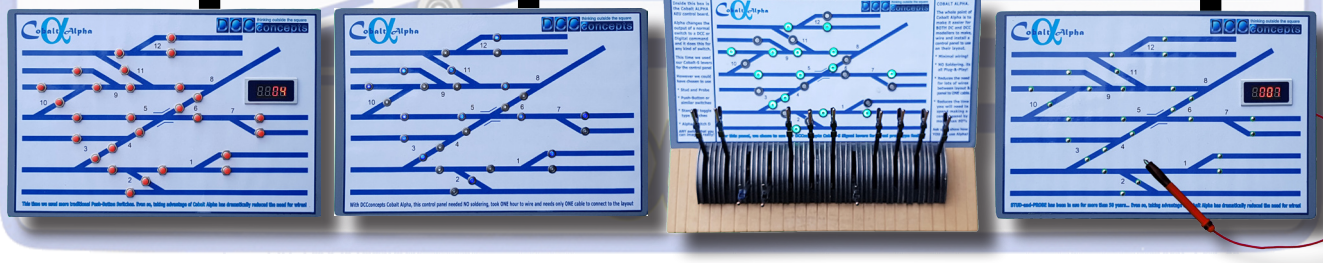

# ALPHA VERSATILITY

BETTER CONTROL & LESS WIRING FOR DC OR DCC MODELLERS

## KEEPING IT ALL PLUG AND PLAY

IN THE DIAGRAM TO THE LEFT, ALL OF THE WIRING IS INSIDE THE CONTROL PANEL AND BECAUSE ALPHA IS INVOLVED, MOST OF THAT BECOMES A SIMPLE-TO-DO PLUG AND PLAY OR SCREW TERMINAL CONNECTION.

EVEN BETTER, ONLY ONE CABLE IS NEEDED TO CONNECT THE CONTROL PANEL TO THE LAYOUT, AND EVEN THAT IS A SIMPLE "PLUG IN" THAT CAN BE PUT IN ANY POSITION ON THE LAYOUT FASCIA.

IF YOU'D LIKE IT EVEN EASIER, ALPHA CENTRAL COMBINES THE ABILITY OF ONE ALPHA AEU & TWO ALPHASWITCH-D SETS TO GIVE OUT OF THE BOX DIGITAL ACCESSORY CONTROL: ALMOST LITERALLY "OPEN BOX, PLUG IT IN, START OPERATING"!

## OR YOU CAN BUY IT ALL READY TO GO!

### ALPHA CENTRAL DCD-AEC



ONLY ONE WIRE TO THE LAYOUT OUT OF THE BOX.

ALPHA CENTRAL CONTROLS 12 ACCESSORY DECODER ADDRESSES.

# CONNECTING ALPHA

CONNECT EASILY, FINISH QUICKLY & GET BACK TO ENJOYING THE TRAINS

## KEEPING IT ALL PLUG AND PLAY

ONCE YOU'VE CONNECTED TO ALPHA, ALMOST ALL THE OTHER WIRING YOU USED TO USE IS NO LONGER NEEDED AS ALL THE INFORMATION IS NOW SENT AS A DIGITAL COMMAND - HOWEVER YOU STILL NEED TO CONNECT YOUR SWITCHES TO THE ALPHA AEU.

TO HELP YOU KEEP THE "SWITCH TO AEU" WIRING TIDY WE CREATED THIS 3-WIRE CABLE.

ONE ROLL WILL BE ENOUGH FOR ALL THE CONNECTIONS

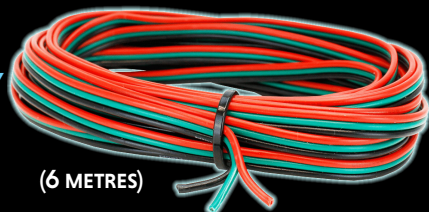

(6 METRES)

ALPHA WIRE. DCD-RGB

# CONTROLLING ALMOST ANY DIGITAL ACCESSORY WITH COBALT ALPHA

INTEGRATING COBALT ALPHA AND MIMIC WITH YOUR CONTROL SYSTEM AND CONTROLLING ACCESSORY PRODUCTS OF MANY TYPES

ONCE YOU HAVE BUILT THE ALPHA-CONTROLLED PANEL, YOU CAN CONTROL YOUR DCC-DIGITAL ACCESSORIES OR ANY ACCESSORY DECODER THAT IS CONNECTED TO THE POWER BUS.

YOU CAN CHOOSE TO USE THE EXISTING POWER BUS OR CREATE A TOTALLY SEPARATED ALPHA-ONLY BUS TO DO IT. IT'S UP TO YOU.

ALPHA REALLY IS THE WAY TO GET THINGS RUNNING WITH MINIMUM FUSS AND BOTHER.

ADDING ALPHA TO YOUR PANEL IS PLUG & PLAY.

CONNECTING AN ALPHA AEU TO ALPHA SWITCH IS SIMPLE TOO.

A PANEL LIKE THIS TAKES LESS THAN 2 HOURS TO ASSEMBLE!

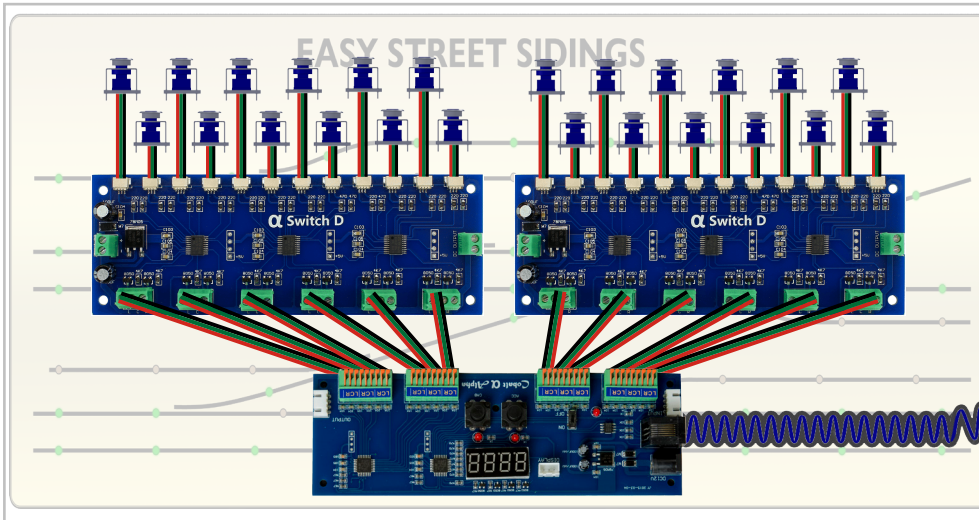

## USE ALPHA PANEL TO CONNECT ALPHA TO A LAYOUT - OR TO UPGRADE OTHER BRANDS

### ALPHA PANEL DCD-DAP

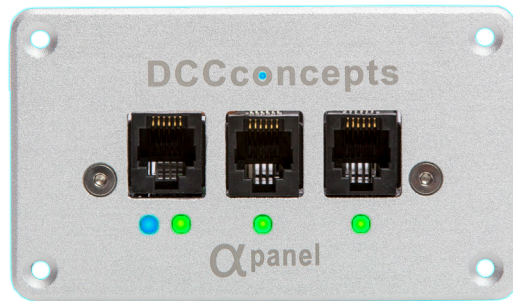

ALPHA-PANEL IS OF COURSE THE PERFECT CHOICE FOR CONNECTION OF COBALT ALPHA PRODUCTS.

HOWEVER IT IS ALSO IDEAL FOR USERS OF OTHER BRAND SYSTEMS SUCH AS NCE AND ROCO.

\* ROCO USES IDENTICAL PLUGS AND WIRING.

\* FOR NCE IT REPLACES BOTH THE GENERAL USE "UTP" AND THE "PCP" POWER CAB PANEL. ALL YOU NEED DO IS MOVE A SWITCH TO MATCH YOUR USE. LED INDICATORS WILL CONFIRM YOUR SETTINGS

THE TINY BLUE LED IN THE LOGO TELLS YOU THAT THE COMMAND BUS IS ACTIVE

THIS BLUE LED WILL LIGHT WHEN AN NCE POWER CAB IS CONNECTED AND THE SWITCH IN THE CORRECT POSITION

THE GREEN LED LIGHTS IF THE SWITCH IS SET FOR THE NCE POWER PRO OR OTHER SYSTEMS

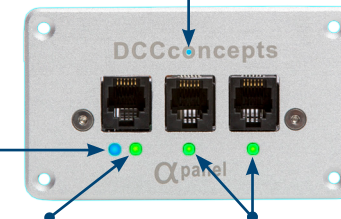

ALPHA-PANEL IS OF COURSE SUPPLIED WITH SCREWS AND INSTRUCTIONS

THESE GREEN LEDS LIGHT TO TELL YOU THAT THE SOCKETS ARE LIVE ~ THE BUS IS AVAILABLE

## ALPHA MIMIC

CONFIRMING EVERY ROUTE CHANGE & KEEPING YOU IN TOUCH WITH ALL PARTS OF YOUR LAYOUT

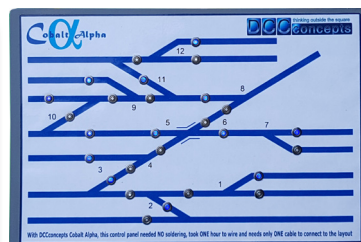
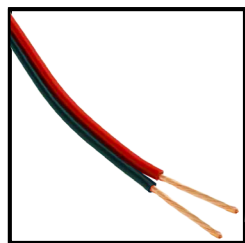
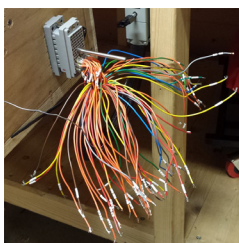

ALPHA MIMIC REDUCES THIS... TO THIS... So - THE MIMIC PANEL CAN THEN BE PUT...

...ANYWHERE AROUND THE LAYOUT. IT CAN IN FACT BE MOVED AROUND, SO IT IS IN ONE PLACE WHEN ON YOUR OWN, ANOTHER WHEN YOU HAVE A CREW WORKING WITH YOU OPERATING THE LAYOUT.

THIS IS PARTICULARLY HELPFUL WHEN YOU NEED TO SEE HOW HIDDEN STORAGE SIDINGS ARE SET, OR GET THE TRACKS ALIGNED PROPERLY ON THE OTHER SIDE OF YOUR WORLD.

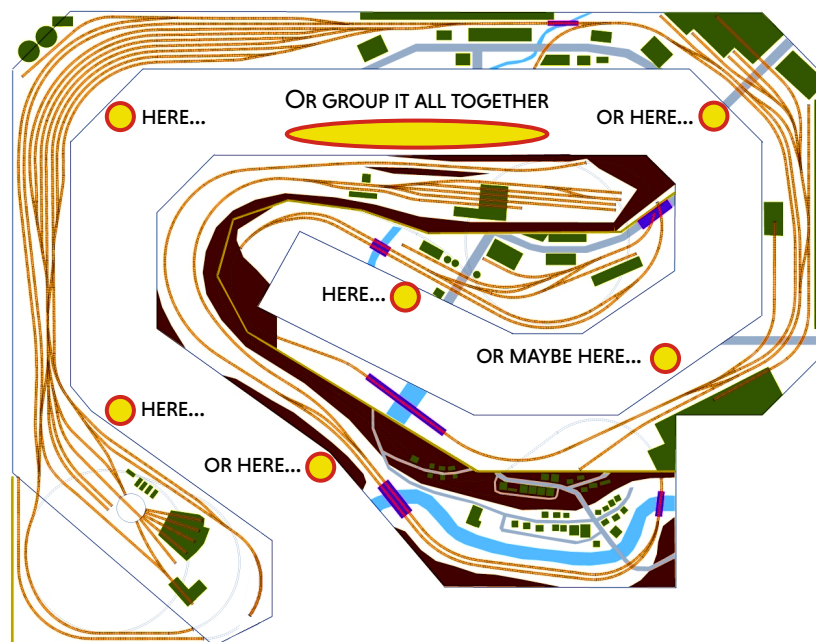

OF COURSE, MANY SMALLER PANELS ARE USEFUL ON LARGER LAYOUTS... AND THEY CAN BE DISTRIBUTED AS PER THE YELLOW "DOTS", OR IF YOU PREFER TO STAY IN ONE PLACE... JUST GROUP THEM ALL TOGETHER.

MIMIC TOTALLY BANISHES COMPLEXITY, SO HOW YOU DO IT IS NOW LIMITED ONLY BY YOUR IMAGINATION!

## ALPHA MIMIC

A FULLY INTERACTIVE LAYOUT DIAGRAM SYSTEM THAT ONLY NEEDS TWO WIRES TO CONNECT IT TO THE LAYOUT!

### MIRROR YOUR CONTROL PANEL TO MAKE IT EASIER

ALPHA MIMIC IS A TOTALLY INDEPENDENT SYSTEM TO THE ALPHA AEU & CENTRAL CONTROLLERS WE HAVE ALREADY SHOWN YOU, BUT IF YOU CHOOSE TO COMBINE THEM BOTH YOU WILL QUICKLY SEE THE POSSIBILITIES FOR IMPROVED OPERATIONS.

ALPHA MIMIC RECEIVES ITS COMMANDS DIRECTLY FROM THE DIGITAL COMMAND POWER BUS, JUST AS YOUR ACCESSORY DECODERS OR COBALT DIGITAL DEVICES DO.

THEREFORE WHEN YOU TELL A POINT MOTOR OR SIGNAL TO CHANGE, ALPHA MIMIC WILL ALSO CHANGE ITS LED DISPLAY TO MATCH THE SETTING YOU CHOSE AUTOMATICALLY.

AS WITH ALL OF OUR ALPHA SERIES PRODUCTS, MIMIC IS TOTALLY PLUG AND PLAY, SO THERE IS NO NEED TO WIRE PANEL LEDs INDIVIDUALLY AND NO NEED TO RUN LOTS OF WIRE, SOLDER LOTS OF JOINTS OR DO OTHER THINGS YOU MAY NOT ENJOY!

MIMIC WORKS WITH ANY BRAND OF DCC SYSTEM - AND DC MODELLERS CAN ALSO ENJOY ITS BENEFITS IF THEY ADOPT ALPHA SNIFFER AND DIGITAL ACCESSORY CONTROL.

### THE ALPHA MIMIC LED

DESIGNED TO MATCH ALPHASWITCH IN COLOUR & STYLE, THEY PRESS FIT TO YOUR PANEL THEN JUST PLUG IN!

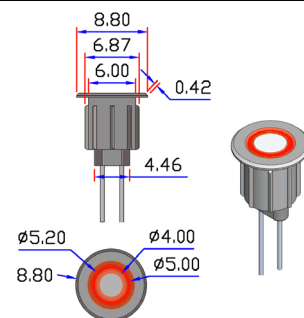

THE LEDs COME IN RED, GREEN, BLUE, RED+GREEN, RED+WHITE.

THE TINY DISC ON THE FACE OF THE LED REDUCES HARSH GLARE AND WILL GIVE YOUR CONTROL PANEL A VERY SOPHISTICATED APPEARANCE.

INSTALLATION COULD NOT BE EASIER AS THEY JUST PUSH-FIT INTO THE PANEL AS LONG AS YOU USE THE CORRECT DRILL SIZE. (6.5MM)

CONNECTION IS SIMPLE. LEDs JUST PLUG INTO THE MIMIC CONTROL BOARD. A WIDE RANGE OF EASY-TO-USE ADAPTERS AND LEADS ARE AVAILABLE SO YOU SHOULD NEVER NEED TO SOLDER OR CUT A WIRE!

PANEL CONSTRUCTION IS QUITE SIMPLE. THE MIMIC MANUAL ALSO INCLUDES CLEAR INSTRUCTIONS TO HELP YOU BUILD A PANEL. YOU WILL REQUIRE ONLY BASIC TOOLS AND THE SIMPLEST OF MATERIALS.

## ALPHA MIMIC

EACH MIMIC BOARD HAS 24 SWITCHABLE OUTPUTS (12 PAIRS). ONE OUTPUT CAN SUPPORT 6 ~ 8 LEDs

ALPHA MIMIC: 5 COLOUR CHOICES, 24 LEDs AND A CONTROL BOARD IN EACH PACK (YOU CAN ALSO BUY LED ADD-ON PACKS TO LET YOU "MIX AND MATCH" COLOURS)

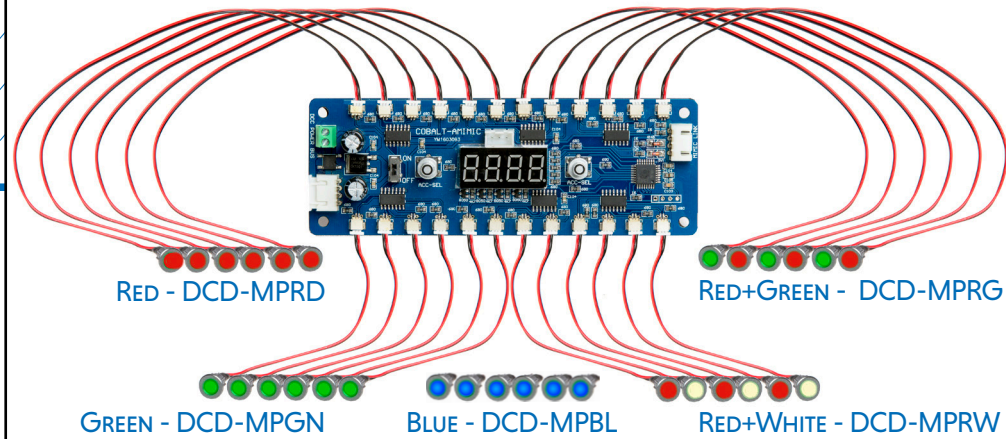

## ALPHA MIMIC

VERY SIMPLE TO UNDERSTAND & USE, MIMIC WORKS PERFECTLY WITH EVERY DCC SYSTEM AVAILABLE

MIMIC WILL WORK WELL ON LAYOUTS IN ANY SCALE AND WITH ANY SIZE LAYOUT, BUT IT IS WITH LARGER LAYOUTS OR IN "AWKWARD AREAS" THAT MIMIC, EITHER ON ITS OWN WITH JUST YOUR DCC SYSTEM OR, COMBINED WITH AN ALPHA AEU OR ALPHA CENTRAL, WILL REALLY HELP YOUR LAYOUT OPERATIONS.

With 24 outputs, one Alpha Mimic pack plus the addition of a few more Mimic LEDs will provide clear, complete visual feedback so you will

never need to guess at the point positions or the point settings for an entire fiddle yard or hidden track area.

This is important for larger layouts, or those at clubs.

Layouts designed for use at exhibitions, and that need several people to operate them also have some other very important needs.

Operators need to be able to guess, see or be told, what is going on in other areas!

Adopting Alpha Mimic goes a long way towards fixing this communication problem as

you can very easily create a duplicate Mimic panel for each area of the layout.

Then, those who are behind the scenes can clearly see the main line settings and those up front will always be aware of what is happening in the staging areas of the layout.

Of course, AlphaSwitch, the Alpha AEU and Alpha Mimic can also be combined, with AlphaSwitch providing the control & Alpha Mimic adding extra LEDs to make sure your track routes are clear to you.

Why not give it a try!

### EASY STREET SIDINGS

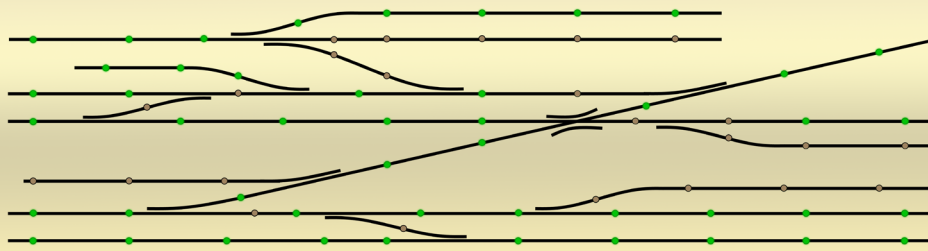

THIS CONTROL PANEL USES ABOUT 60 MIMIC LEDs TO SHOW BOTH ROUTES AND TURNOUT POSITIONS.

PANEL CONSTRUCTION IS EASY AND WE HELP BY PROVIDING YOU WITH RESOURCES THAT YOU CAN USE - INCLUDING INSTRUCTIONS FOR MAKING THE PANEL (WITH NO SPECIAL TOOLS NEEDED) PLUS A SIMPLE COMPUTER FILE WHICH HAS TEMPLATES FOR TURNOUTS AND PANEL DETAIL TO MAKE CREATION EASIER.

WHEN THE PANEL HAS BEEN CREATED IT WILL ONLY TAKE ABOUT TWO HOURS TO ADD LEDs & WIRE IT ALL. ONCE WIRED, CONNECTION TO YOUR LAYOUT NEEDS ONLY TWO WIRES. IT COULDN'T BE EASIER!

**MIMIC ADAPTERS & ACCESSORIES ON PAGE 39**

**PRODUCT RANGE :**

**DCCCONCEPTS ALPHA MIMIC**

**PRIMARY DESIGN GOALS:**

**MAKE IT POSSIBLE TO CREATE INTELLIGENT, HIGH QUALITY MIMIC PANELS WITH NO NEED FOR SPECIAL SKILLS OF COMPLEX WIRING**

**APPROPRIATE SCALE USE:**

**USABLE WITH LAYOUTS OF ANY PROTOTYPE IN ALL MODEL SCALES**

**USER SKILL REQUIREMENT:**

**LOW - PLUG IN OR BASIC WIRING. NO SOLDERING.**

**APPLICATION / SUITABILITY:**

**SUITABLE FOR DCC + DC USERS. (ADAPTERS MAY BE REQUIRED)**

**SWITCHING INTERFACE:**

**ONLY TWO WIRES NEEDED. REQUIRES A DCC/DIGITAL BUS**

**(DC USERS WILL NEED TO CONNECT VIA ALPHA SNIFFER ETC)**

**OTHER-BRAND INTERACTION:**

**INTERFACES WITH ALL DIGITAL/DCC SYSTEMS DIRECTLY**





# ALPHA MIMIC GROUND SIGNALS

CONNECT UP TO 24 SIGNALS TO JUST ONE MIMIC CONTROL BOARD.  
CONNECT THE MIMIC CONTROL BOARD WITH ONLY TWO WIRES!

EACH ALPHA MIMIC CONTROL BOARD HAS THE ABILITY TO CONTROL 12 DCC ADDRESSES. EACH OF THE DCC ADDRESSES MANAGES TWO OUTPUTS. THIS MEANS THAT A MIMIC CONTROL BOARD CAN ACTUALLY BE USED TO CONNECT & CONTROL 24 MIMIC GROUND SIGNALS.

For most modellers this will mean that just one Alpha Mimic controller controls the signals of an entire yard.

Example: All of the ground signals at both ends of the loops of a 24 turnout, 13 track fiddle yard. Awesome!

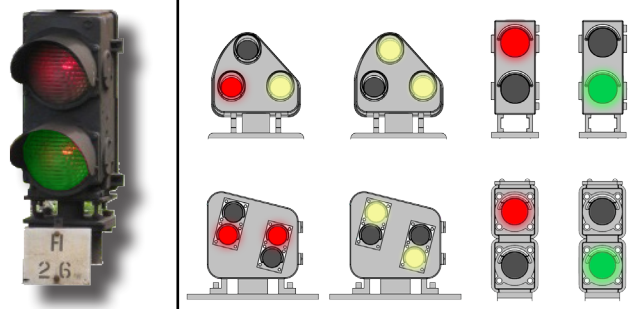

## ALPHA MIMIC GROUND SIGNAL PACKS (WITH ALPHA MIMIC CONTROL BOARD)

- DCD-MGS-BR: 12 x 3-LIGHT UK SIGNALS + DCC/MIMIC CONTROL PCB & ACCESSORIES.
- DCD-MGS-MG: 12 x 4-LIGHT UK SIGNALS + DCC/MIMIC CONTROL PCB & ACCESSORIES.
- DCD-MGS-RG: 12 x 2-LIGHT UK SIGNALS + DCC/MIMIC CONTROL PCB & ACCESSORIES.
- DCD-MGS-US: 12 x 2-LIGHT USA SIGNALS + DCC/MIMIC CONTROL PCB & ACCESSORIES.

## ALPHA MIMIC GROUND SIGNAL ADD-ON PACKS (NO MIMIC CONTROL BOARD)

- DCD-GS-BR: 12 x 3-LIGHT UK SIGNALS + ACCESSORIES (NO MIMIC CONTROL BOARD)
- DCD-GS-MG: 12 x 4-LIGHT UK SIGNALS + ACCESSORIES (NO MIMIC CONTROL BOARD)
- DCD-GS-RG: 12 x 2-LIGHT UK SIGNALS + ACCESSORIES (NO MIMIC CONTROL BOARD)
- DCD-GS-US: 12 x 2-LIGHT USA SIGNALS + ACCESSORIES (NO MIMIC CONTROL BOARD)

# ALPHA MIMIC HO SCALE GROUND SIGNALS

3.5MM SCALE (HO) MIMIC GROUND SIGNALS FOR USA, AUSTRALIA ETC...  
INCREDIBLE VALUE. DCC CONTROLLED AND READY TO USE. IN PACKS OF 12.

DCD-MGS-US A COMMON FORM OF GROUND SIGNAL COVERING A WIDE PERIOD

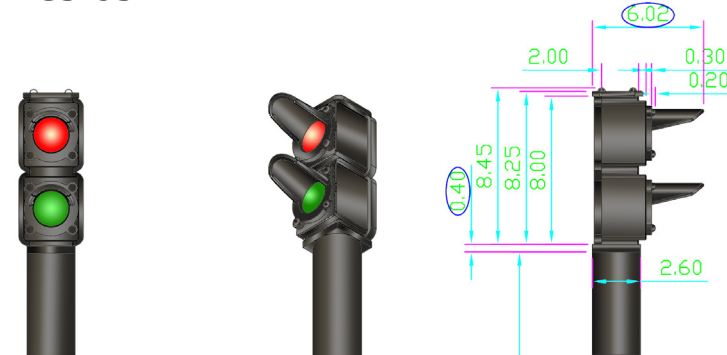

# MIMIC SIGNALS: WHAT IS INSIDE THE PACK?

EACH SIGNAL TYPE COMES WITH 12 SIGNALS & ALL OF THE PARTS SHOWN BELOW.  
(ADD-ON PACKS ARE ESSENTIALLY THE SAME BUT WITHOUT A MIMIC CONTROL BOARD)

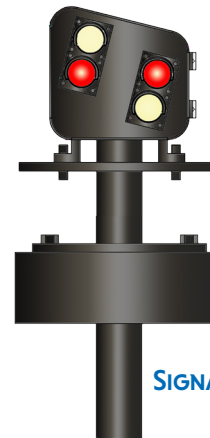

12x WORKING FINELY SCALED SIGNAL HEADS WITH LEDs AND LOTS OF DETAIL

12x MATCHING PROTOTYPE BASES (ADJUSTABLE)

SIGNAL POSTS ARE BRASS

CONTROL BOARD THAT NEEDS ONLY 2 WIRES TO CONNECT & 3 x Y-CONNECT AND REVERSE CONNECT ADAPTERS

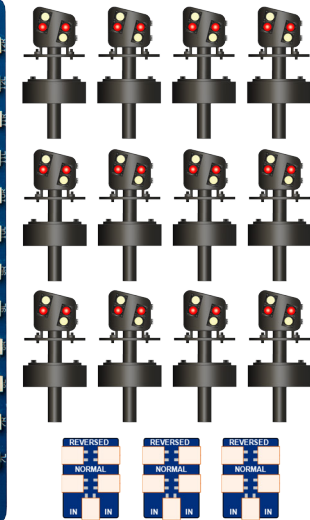
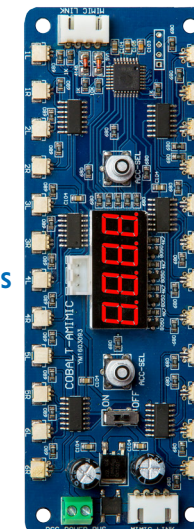

# THE COBALT ALPHA ACCESSORY RANGE

WE HAVE DONE OUR BEST TO MAKE SURE THAT NO MATTER HOW YOU WANT TO CONNECT ALPHA, OR HOW BIG OR SMALL YOUR CONTROL PANEL IS, IT WILL STAY EASY TO DO AND REMAIN PLUG AND PLAY.

WE HAVE ALSO ADDED A "MIMIC LED TO ALPHA SWITCH" INTERFACE, TO INTEGRATE ALPHA & MIMIC

## ALPHA 6-WIRE CURLY CORD

THE DIRECT CONNECTION FOR ALPHA (ALSO FOR NCE POWER CAB)

DCD-ACL: 6-WIRE RJ12 CONNECTORS, 6' (1.8M) EXTENDED



CREATED FOR ALPHA, BUT IDEAL FOR NCE POWERCAB TOO!

## ALPHASWITCH TEMPLATES

TO HELP YOU LAY OUT THE PANEL SWITCH POSITION EASILY

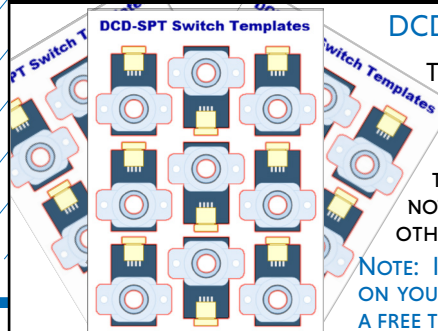

DCD-SPT (PACK OF 36)

THESE PRE-CUT AND SELF ADHESIVE TEMPLATES WILL HELP YOU TO PLAN YOUR PANEL SO THAT THE SWITCHES DO NOT INTERFERE WITH EACH OTHER. (36 IN EACH PACK)

NOTE: IF YOU DRAW PANELS ON YOUR COMPUTER, THERE IS A FREE TEMPLATE ON-LINE.

## ALPHASWITCH EXTENSION LEADS

EXTENSION LEADS (IN PACKS OF SIX)

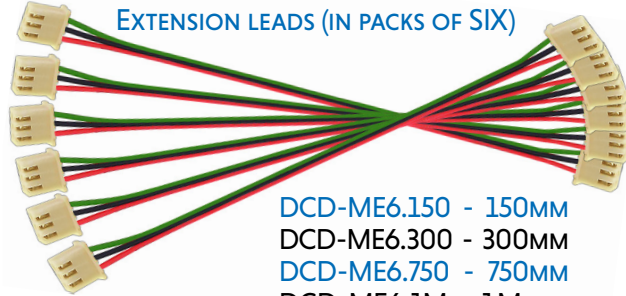

- DCD-ME6.150 - 150MM
- DCD-ME6.300 - 300MM
- DCD-ME6.750 - 750MM
- DCD-ME6.1M - 1METRE

## ALPHASWITCH Y-CONNECTORS

Y AND PARALLEL CONNECTION OF ALPHASWITCHES - MADE EASIER

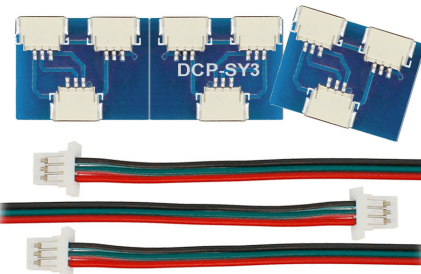

DCD-SY3

IN PACKS OF 3 AS AN EASY "SNAP OFF PCB" (WITH 3X PLUG AND PLAY LEADS)

AN SY3 ADAPTER CAN BE USED TO MAKE ONE SWITCH WORK TWO DEVICES. OR USE IT TO LINK TWO SWITCHES ONTO ONE DEVICE.

## ALPHA AEU EXTENSION DISPLAY

REPEATS ALL ALPHASWITCH COMMANDS AS THEY ARE MADE



DCD-ADX

A DIGITAL DISPLAY TO REPEAT ALL ALPHA AEU ADDRESS COMMANDS

THIS DISPLAY HAS A HIGH QUALITY ALLOY MOUNTING FASCIA.

IT PLUGS INTO ALPHA AEU. THE LEAD IS ONE METRE LONG (39")

## ALPHA AEU~ALPHASWITCH WIRES

PRE-CUT AND TINNED TO MAKE CONNECTION TO ALPHA AEU EVEN EASIER

DCD-SW12.150:



A PACK OF TWELVE READY TO USE RED, GREEN AND BLACK WIRES (150MM)

A VERY EASY WAY TO CONNECT ALPHA AEU AND ALPHASWITCH OR ANY OTHER SWITCH YOU CHOOSE!

## ALPHASWITCH LEAD CONNECTORS

BUILD LARGER PANELS AND KEEP THE ENTIRE PANEL TOTALLY PLUG AND PLAY

DCD-MJ6: SOLD IN PACKS OF SIX, THIS IS THE MOST BASIC "JOINER" FOR CONNECTING ALPHASWITCH EXTENSION LEADS

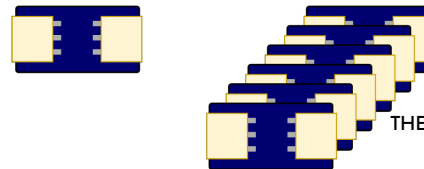

USING NEAT AND TIDY JOINERS LETS US GREATLY REDUCE THE PRICE OF THE LEADS!

BECAUSE CONTROL PANELS ARE NOT LARGE, YOU'LL PROBABLY NEED ONLY ONE PACK FOR EVEN A LARGER CONTROL PANEL.

## ALPHASWITCH EXTENSION WIRE

AN ALTERNATIVE TO EXTENSION LEADS FOR THOSE WHO LIKE TO SOLDER.

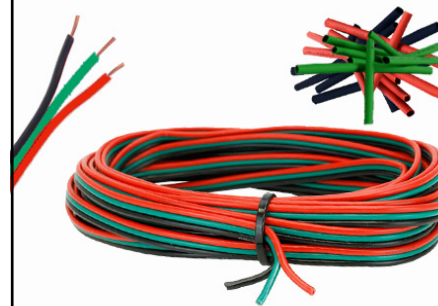

DCD-SW3.10

10 METRES OF FINE TRIPLE RGB WIRE.

SUPPLIED WITH RED, GREEN AND BLACK HEAT-SHRINK

## ALPHA-TO-MIMIC LED ADAPTERS

EXTEND ALPHA PANELS BY ADDING MIMIC ROUTE INDICATION TOO

**DCD-SMA3:** SOLD IN PACKS OF 3, THIS ADAPTER LETS YOU ADD SEVERAL MIMIC LEDs TO ALPHA-SWITCH FOR ROUTE INDICATORS

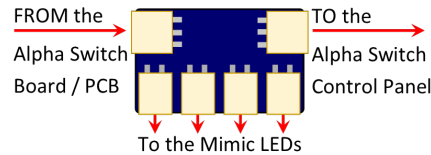

PLEASE NOTE: THE MIMIC LED COLOUR SHOULD MATCH YOUR ALPHA SWITCH LED COLOUR. IF YOU USE DIFFERENT COLOURS YOU WILL NEED TO ADD A RESISTOR SO THEY WILL FUNCTION PROPERLY

## ALPHA MIMIC & ALPHA MIMIC GROUND SIGNAL ACCESSORIES

VERY SIMPLE TO UNDERSTAND AND USE, ALPHA MIMIC AND OUR ALPHA MIMIC GROUND SIGNALS WORK PERFECTLY WITH EVERY DCC SYSTEM. WITH THE WIDE RANGE OF ACCESSORIES AVAILABLE, NO MATTER WHERE YOU INSTALL THEM, PLUG & PLAY DESIGN MAKES IT EASY TO DO.

## ALPHA MIMIC EXTENSION WIRE

AN ALTERNATIVE TO EXTENSION LEADS FOR THOSE WHO LIKE TO SOLDER.



**DCD-MW2.10**

10 METRES OF FINE TWINNED WIRE.

SUPPLIED WITH RED AND BLACK HEAT-SHRINK

## KEEPING IT SIMPLE AND VERSATILE

Making control panel creation easier by removing the need for stripping and soldering of many wires by using a plug and play approach has really simplified control or mimic panel creation and design.

It also adds another benefit you may not have thought of.

All control panel parts, whether they are AlphaSwitch, Mimic LEDs or adapters and extension leads as shown on this page, become 100% re-usable for your next panel.

It also makes panel revision easy, as adding a new siding or turnout just needs another item or 2 to be plugged in!

## EXTENSION LEAD CONNECTORS

SIMPLE PLUG-AND-PLAY CONNECTIONS FOR ALPHA MIMIC LEADS

**DCD-MJ6:** SOLD IN PACKS OF SIX, THIS IS THE MOST BASIC "JOINER" FOR CONNECTING ALPHA MIMIC EXTENSION LEADS

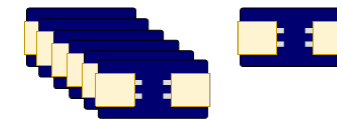

USING THESE NEAT & TIDY JOINERS LETS US GREATLY LOWER THE PRICE OF THE LEADS!

BECAUSE CONTROL PANELS ARE NOT LARGE, THE MJ6 JOINERS WILL BE USED MOSTLY WITH ALPHA MIMIC GROUND SIGNALS

## ALPHA MIMIC EXTENSION LEADS

BUILD MIMIC PANELS OF ANY SIZE AND REMAIN TOTALLY PLUG AND PLAY

EXTENSION LEADS (IN PACKS OF SIX)

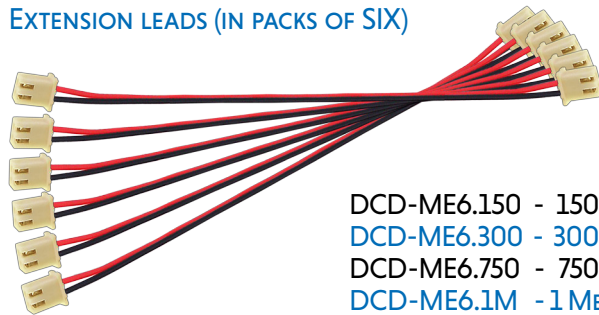

DCD-ME6.150 - 150MM  
 DCD-ME6.300 - 300MM  
 DCD-ME6.750 - 750MM  
 DCD-ME6.1M - 1METRE

## REVERSING MIMIC CONNECTIONS

SWAP LED POLARITY TO CHANGE INDICATIONS EASILY AND AT WILL.

**DCD-MRA3:** SOLD IN PACKS OF 3, THIS ADAPTER LETS YOU ADD MORE LEDs & CHOOSE INDICATION VIA CHANGING OF POLARITY

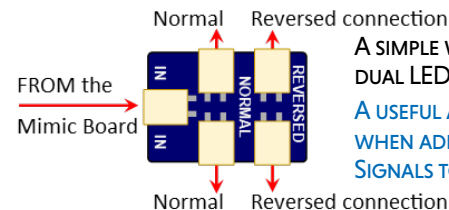

A SIMPLE WAY TO ADD DUAL LED INDICATION. A USEFUL ACCESSORY WHEN ADDING MIMIC SIGNALS TO LOOPS!

## CONNECT MULTIPLE MIMIC LEDs

JOIN ONE-TO-ONE OR MANY TO ONE OUTPUT WITHOUT COMPLICATION

**DCD-MMA3:** SOLD IN PACKS OF 3, THIS ADAPTER WILL LET YOU CONNECT UP TO SIX MIMIC LEDs TO ONE MIMIC OUTPUT

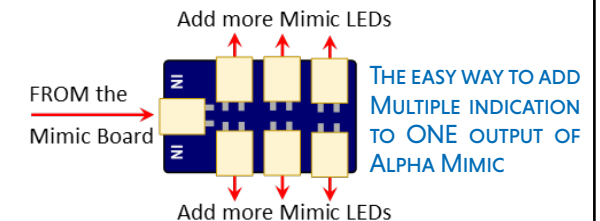

## POWERBASE

FITTING POWERBASE TO YOUR WHOLE LAYOUT COSTS LESS THAN AN AVERAGE LOCOMOTIVE YET IT WILL GIVE THE RUNNING QUALITIES OF ALL OF YOUR TRAINS THE MOST SIGNIFICANT PERFORMANCE BOOST IMAGINABLE.

POWERBASE IS VERY EASY TO LAY, AND ONCE IT IS BALLASTED, IT IS TOTALLY INVISIBLE



COMPREHENSIVE STEP-BY-STEP INSTRUCTIONS @ [WWW.DCCCONCEPTS.COM](http://WWW.DCCCONCEPTS.COM)

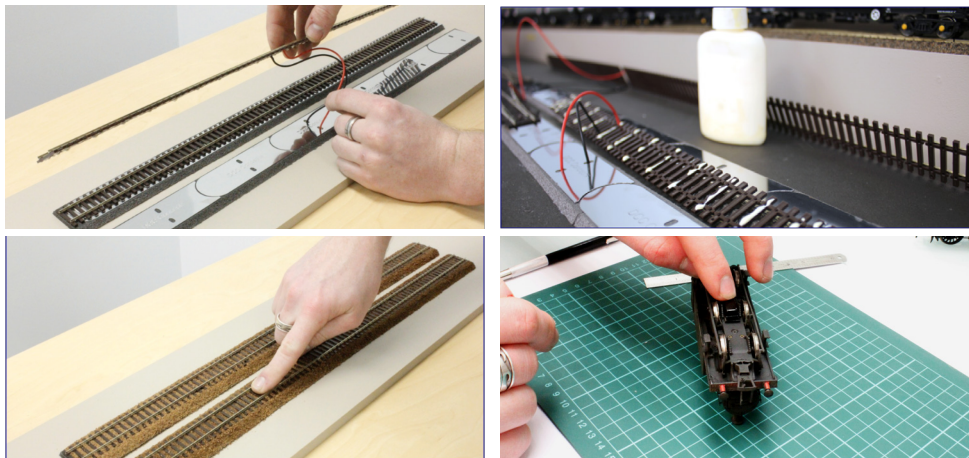

WHEN THE PLATES ARE LAID, INSTALL POWERBASE MAGNETS UNDER THE LOCOS WITH DIESELS AND SMALLER STEAM LOCOS, THIS TAKES ONLY A FEW MINUTES!

## POWERBASE MAGNETS FOR YOUR LOCOMOTIVES.

POWERBASE PACKS COME COMPLETE WITH STANDARD MAGNETS, BUT THERE IS ALSO A RANGE OF MAGNET PACKS THAT SUIT SPECIFIC LOCO TYPES AND SIZES. SEE P 41 OR SEARCH [WWW.DCCCONCEPTS.COM](http://WWW.DCCCONCEPTS.COM)

# POWERBASE

DOUBLE THE PULLING POWER OF MANY LOCOS. SIGNIFICANTLY IMPROVE THE QUALITY AND RELIABILITY OF ELECTRICAL PICKUP.

MAGNETS ARE NOT NEW, BUT THE WAY THAT POWERBASE MAKES THEM WORK FOR YOU TO IMPROVE YOUR LOCO PERFORMANCE DEFINITELY IS!

Many years ago, model railway track was made of steel and the wheels were made of similar material.

Loco bodies were cast in metal and chassis were quite heavy so the grip of the wheels to the rail was good, so they were able to

pull long or heavy trains up hills as well as on the flat.

Over time, things changed. Because steel rusts, brass then nickel silver were adopted for rails.

Wheels also changed, to nickel-silver or similar.

Bodies also became plastic as it let manufacturers make them more detailed.

The problem is, nickel silver is a very slippery alloy, so with lead & heavy metals

removed from chassis and much lighter plastic loco bodies, while locos become nicer too look at, they are very often unable to manage a realistic load, especially on gradients.

With all of the track laid on the flat, things can be OK, but most of our model railway rooms are just not big enough, so gradients or hills really are needed.

This creates a problem...

### PRODUCT RANGE :

### DCCCONCEPTS POWERBASE

#### PRIMARY DESIGN GOALS:

KEEP IT SIMPLE WITHOUT DIFFICULT INSTALLATION, SPECIAL TOOLS OR SPECIFIC SKILLS. MAKE IT POSSIBLE TO HAVE EXCEPTIONAL TRAIN-PULLING PERFORMANCE ON GRADIENTS. IMPROVE THE QUALITY OF RUNNING AND POWER PICKUP FOR ALL LOCOS.

#### APPROPRIATE SCALE USE:

OK WITH MOST SCALES BUT SPECIFICALLY CREATED FOR OO/HO+N

#### USER SKILL REQUIREMENT:

LOW - JUST TAKE YOUR TIME , FOLLOW INSTRUCTIONS CAREFULLY.

#### APPLICATION / SUITABILITY:

ANY PROTOTYPE, ANY FORM OF CONTROL, ANY LAYOUT SIZE. NO NEED TO OPEN UP A LOCO FOR DIFFICULT MODIFICATIONS.

#### TOOLS YOU MIGHT NEED:

GOOD QUALITY PVA-TYPE GLUE, SUPERGLUE, SCISSORS, BLACK PERMANENT MARKER PEN, WEIGHTS TO USE WHILE GLUEING THE PLATES DOWN, PLUS OTHER COMMON HOBBY TOOLS.

# POWERBASE

THE QUICKEST & MOST SIGNIFICANT PERFORMANCE BOOST IMAGINABLE

Unfortunately, to take one track over another they need to be quite steep!

But - add a gradient that is steep enough to do the job & now your locos can only just manage a small train!

As if that was not enough, light locos don't have good contact with the rail any more. This leads to yet another problem. Poor or erratic electrical pickup.

This isn't helped by the fact that while nickel-silver rails corrode less than steel, the tarnishing is mostly copper oxide - the same material that resistors are made of! Added to the light weight of small locos, this leads to erratic performance - even if you conscientiously clean the track regularly.

PowerBase remedies all of these problems at once and it is very easy to install and use.

You DO need to install the PowerBase plates under the track, so its easier on new layouts - however, it is definitely worth taking the time to redo problem areas on existing layouts too.

The process itself is very simple as the "Photo Story" on the left page confirms.

With Powerbase in place, the next step is to add two or 3 PowerBase magnets underneath your locos. Like magic, two things will happen every single time!

Power pickup will improve significantly... because the addition of the magnets to your locos acts just like increasing their weight several times over.

Locos instantly become extremely sure-footed... so while they slipped before with a small or medium load they can now pull realistic trains up all of your gradients.

## POWERBASE PACKS ~ OO/HO

STARTER PACK, VALUE PACK AND ADD-ON POWERBASE PLATE PACKS

**DCX-PBBVP** THE VALUE PACK IS REALLY GOOD VALUE AND A GREAT WAY TO START WITH POWERBASE. CONTAINS 5 METRES OF POWERBASE PLATES, AND 12 STANDARD SIZE SUPER-MAGNETS.



**DCX-PBKit**

JUST WANT TO TRY IT?

THIS "STARTER KIT" CONTAINS 2.5M OF PLATES & 6 MAGNETS.



**DCX-PBB**

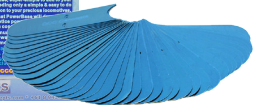

ONCE YOU START USING IT, YOU'LL WANT MORE... THIS "ADD-ON" PACK CONTAINS 5 METRES OF POWERBASE PLATES AT SURPRISINGLY LOW COST.

## POWERBASE PACKS ~ N, HOE/M

STARTER PACK, VALUE PACK AND ADD-ON POWERBASE PLATE PACKS

**DCX-PBBVNP** N SCALE VALUE PACK (5 METRES OF PLATES AND 12 SUPER-MAGNETS)  
**DCX-PBKitN** N SCALE STARTER KIT (2.5 METRES OF PLATES AND 6 SUPER-MAGNETS)

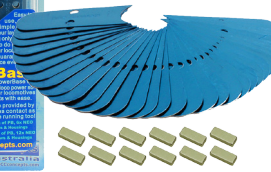

**DCX-PBBN** THE N SCALE ADD-ON PACK. CONTAINS 5 METRES OF POWERBASE PLATES TO LET YOU EXPAND COVERAGE ECONOMICALLY.

## POWERBASE ETCHED HANGERS

A RANGE OF ETCHED BRASS HANGERS TO LET YOU MOUNT MAGNETS CLOSER TO THE RAILS WHEN YOUR LOCOMOTIVES HAVE LARGER WHEELS



**DCX-PBEX** For OO AND HO LOCOS  
 EACH FRET CONTAINS 39 ETCHED HANGERS.  
 HANGER DEPTHS VARY FROM 4MM TO 8MM TO ACCOMMODATE ALL SIZES OF DRIVING WHEELS.



**TIPS:** BEFORE BENDING, IT HELPS TO ANNEAL THE ETCHINGS BY HEATING RED HOT AND THEN QUENCHING IN COLD WATER. ADD SOLDER TO THE BENDS FOR STRENGTH. COLOUR THEM WITH BLACK MARKER PENS.

## POWERBASE "SPECIAL MAGNET PACKS" AND OTHER ITEMS

SPECIAL EXTREME MAGNETS FOR DIESELS AND OTHER INSTALLATIONS, SPECIAL MINI-MAGNETS FOR N SCALE OR SMALLER LOCOMOTIVES



**DCX-PBMXE**  
 A WIDE SELECTION OF LARGER FLAT AND THINNER MAGNETS. THEY ARE IDEAL FOR DIESEL, ELECTRICS OR LOCO'S WITH SMALL WHEELS - ESPECIALLY THOSE WITH POWERED BOGIES WHICH HAVE BASE PLATES THAT ARE SET A LITTLE CLOSER TO THE RAIL-HEAD!



**DCX-PBMXS**  
 A WIDE RANGE OF SMALL, FLAT, DISC AND CYLINDER MAGNETS. THIS RANGE IS IDEAL FOR N-SCALE, SMALLER INDUSTRIAL OR NARROW GAUGE USE. ALSO USEFUL ON COACHES ETC., TO IMPROVE POWER PICKUP.

**DCX-PBM**  
 A 12 PACK OF STANDARD MAGNETS. THIS PACK ALSO INCLUDES SCREWS & A DRILL. THESE ALLOW YOU TO USE THE PACKAGING TO CREATE POCKETS. (INSTEAD OF GLUEING THE MAGNETS ONTO THE LOCO CHASSIS).



## THE COBALT CDU-2 CAPACITOR DISCHARGE UNIT

WHILE COBALT MOTORS ARE ALL MOTOR DRIVEN, THAT DOES NOT MEAN WE FORGOT ABOUT SOLENOIDS OR THE MODELLERS THAT USE THEM - SO THE CDU-2 WAS CREATED TO BE THE BEST CDU EVER MADE!

CDU-2 wired with shared load

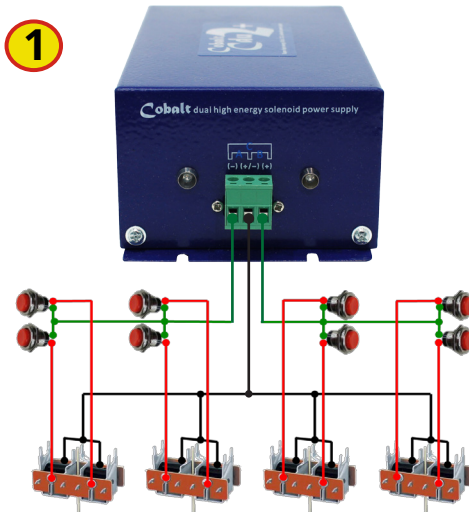

CDU-2 reducing your wiring!

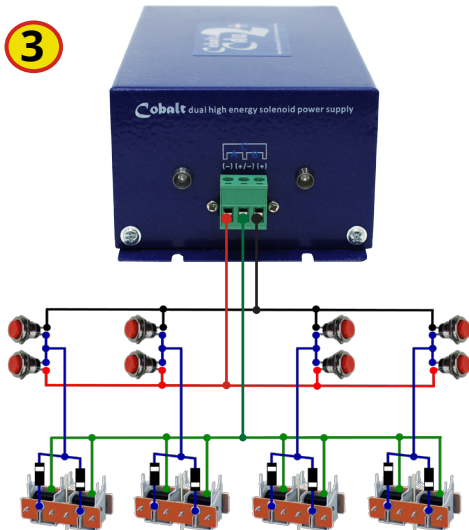

CDU-2 IS THE BEST CHOICE FOR USE WITH DIODE MATRIX SWITCHING!

CDU-2 in Ultra-Power mode

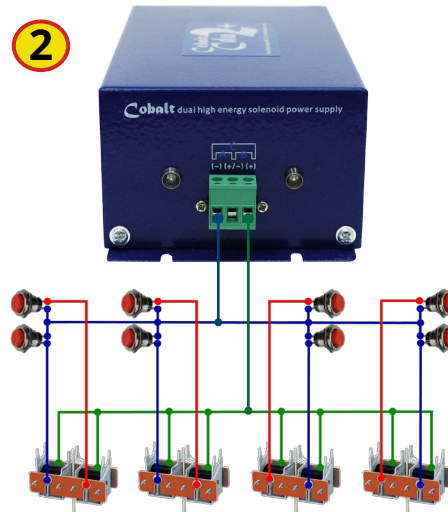

CDU-2 with Kato and LGB etc

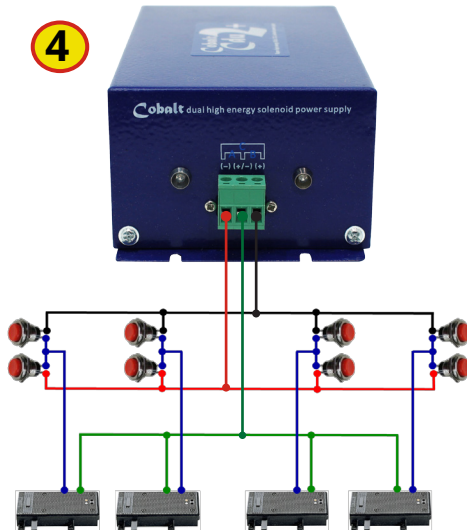

CDU-2 is not currently available in Australia

## COBALT CDU-2

PLUG IN A CDU-2 AND DRAMATICALLY IMPROVE THE WAY YOUR SOLENOIDS PERFORM EVERY TIME!

### WHY MAKE IT THE SAME WHEN WE CAN MAKE IT BETTER?

While we focus very much on smooth, turnout-friendly motor-drive turnout motors, we are also aware that many modellers already own, or may prefer, solenoids. Additionally, some popular brands of track already have solenoids built in to their powered turnouts.

Solenoids always require a little more than the basic power from a controller to work well, and the answer can be a CDU or capacitor discharge unit, which boosts power so that the solenoids get the energy they require. Usually, this needs a transformer and a CDU unit to be bought and connected to the turnouts and the control system.

We do not like to just duplicate what others do, especially when we can clearly see how to make it much better.... so CDU-2 has several features not available elsewhere!

CDU-2 is fantastic value compared to other CDUs. It's ready to use without complex wiring and it is totally complete. It has much more energy than other CDUs. It can be wired conventionally - or it can make it easier for you by using our unique 3-terminal connections to reduce wiring to each solenoid from three wires to only two. That's 33% less wire and fewer connections and soldered joints than you would normally need!

CDU-2 will also improve the performance of 2-wire solenoids such as KATO or LGB!

### EXPLAINING THE CDU-2 PERFORMANCE ADVANTAGE!

- 1 The Cobalt CDU-2 is TWO high power CDUs in one box - and - each CDU is several times more powerful than any other CDU available! Wire like this & you can also share solenoids between them, making sure performance is always at its best!
- 2 Because the two CDUs can be wired together to make one super-high power CDU, there is really NO limit to how many solenoids can be changed - all at the same time. We tested 12 at once and never came close to reaching the limit!
- 3 This lets us reduce the wires needed wires from 3 to 2 by adding diodes to 3-wire motors like Peco, Hornby, Atlas or Seep. This also creates an easy way to directly drive 2-wire DC solenoids like those made by Kato and LGB, as with CDU-2s two internal CDU units linked, it creates a common base wire that is both (+) and (-), with the two outer terminals becoming (+) and (-) in turn.
- 4

## TWISTED POWER BUS WIRE

TWISTING CANCELS INDUCTION AND IMPROVES POWER DELIVERY

Quality pre-tinned copper wire, great prices.

DCW-TW50-3.5 ~ 50M/3.5MM<sup>2</sup> (11GAUGE)

DCW-TW25-3.5 ~ 25M/3.5MM<sup>2</sup> (11GAUGE)

DCW-TW50-2.5 ~ 50M/2.5MM<sup>2</sup> (13GAUGE)

DCW-TW25-2.5 ~ 25M/2.5MM<sup>2</sup> (13GAUGE)

DCW-TW50-1.5 ~ 50M/1.5MM<sup>2</sup> (15GAUGE)

DCW-TW25-1.5 ~ 25M/1.5MM<sup>2</sup> (15GAUGE)

DCW-TW50-1.0 ~ 50M/1.0MM<sup>2</sup> (17GAUGE)

DCW-TW25-1.0 ~ 25M/1.0MM<sup>2</sup> (17GAUGE)



# WIRING & THE LAYOUT

**THE WIRE YOU CHOOSE WILL MAKE A BIG DIFFERENCE TO THE QUALITY OF YOUR LAYOUT PERFORMANCE**

**"LAYOUT WIRE" DOES NOT EXIST!**

We get quite angry when we see shops promoting "layout wire" ...and then selling you 7 x 0.2mm wire which has lower power-delivery ability than fuse wire!

That is because each application on your layout will work at its best only if the right wire is chosen.

Think of wire, electricity & power delivery as being very similar to plumbing or the way that water flows.

Choose wire based on need. If you want to deliver all of the power - the wire (pipe) diameter needs to be big enough. If the wire is too small, pressure (voltage) will need to be increased to get enough at the end.

And... if there are several things attached (like taps) then the whole system needs to be balanced or some of them will not work properly if others are in use!

## DCC CONTROL BUS WIRING

CABLE, CONNECTORS AND PRE-MADE LEADS MADE TO ORDER

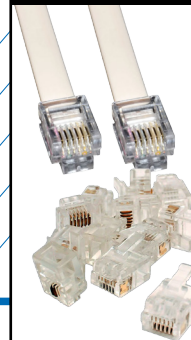

6-core Control bus flat cables and their RJ12 connectors

DCW-6CDPM2 ~ 2 metres

DCW-6CDPM4 ~ 4 metres

DCW-6CD(X) ~ Lead made to order

DCW-6CD50 ~ Roll of 50 metres

DCW-6P6C-12 ~ 12x RJ12 connectors

## SINGLE POWER BUS WIRE

SINGLE WIRES FOR THE POWER BUS FOR THOSE WHO PREFER IT



Available by the metre, but always best value in reels! Of course, in the part #, BK = Black, RD = Red. All sizes are available in either 50 or 25 metre reels.

DCW-BK50-3.5 or BK25-3.5 ~ 3.5MM<sup>2</sup> (11G)

DCW-RD50-3.5 or RD25-3.5 ~ 3.5MM<sup>2</sup> (11G)

DCW-BK50-2.5 or BK25-2.5 ~ 2.5MM<sup>2</sup> (13G)

DCW-RD50-2.5 or RD25-2.5 ~ 2.5MM<sup>2</sup> (13G)

DCW-BK50-1.5 or BK25-1.5 ~ 1.5MM<sup>2</sup> (15G)

DCW-RD50-1.5 or RD25-1.5 ~ 1.5MM<sup>2</sup> (15G)

## PLAITED WIRE FOR SOLENOIDS

KEEPS THE WIRING VERY TIDY & REDUCES COIL-RELEASE INDUCTION

Plaiting the solenoid wires has two very real advantages.

Plaiting keeps your wiring tidy and it wraps the wire around each other in two opposing directions, reducing induction and the very high voltage spike that will be generated every time the coil voltage is released - so your switches will last longer.



## DROPPER WIRE IN 9 COLOURS

WITH 26 STRANDS OF 0.15MM COPPER, THIS IS THE BEST AVAILABLE. 9 COLOURS TO CHOOSE FROM

DCW-DSRED50~Red

DCW-DSBK50~Black

DCW-DSYLW50~Yellow

DCW-DSBLU50~Blue

DCW-DCGRY50~Grey

DCW-DSGRN50~Green

DCW-DSWHT50~White

DCW-DSPNK50~Pink

DCW-DSORG50~Orange

ALSO USEFUL FOR CLEARLY COLOUR CODED GENERAL WIRING CONNECTIONS ALL AROUND YOUR LAYOUT

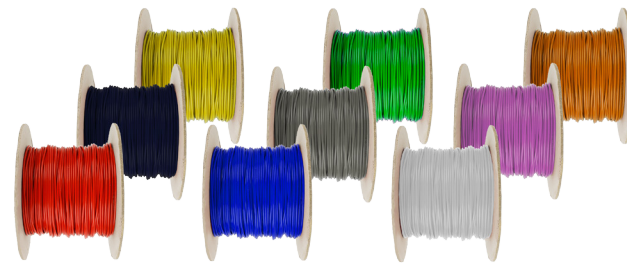

## LAYOUT WIRING ESSENTIALS

USEFUL ACCESSORIES THAT WILL MAKE IT EASIER FOR YOU TO WIRE THE LAYOUT FOR THE BEST RESULTS

Two solid brass power distribution bars with swivel mounting feet

DCC-Bbar2

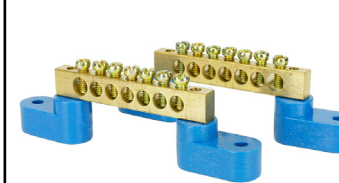

12-way "Pluggable" strip connectors (two pairs)

DCC-Strip

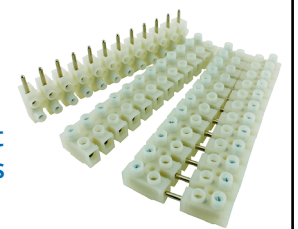

DCC-BT2

2x Bus terminators. Connect to the ends of the power bus to suppress voltage spikes

## POWER BUS WIRING TAGS

THE EASIEST WAY TO SECURE THE BUS AND ATTACH THE DROPPERS

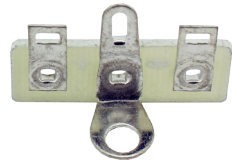

**DCC-TAG25 ~ A PACK OF 25 POWER BUS & DROPPER TAGS**

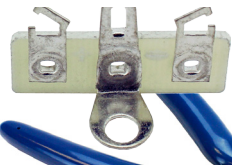

**DCC-TAG50 ~ A PACK OF 50 POWER BUS & DROPPER TAGS**

Easy to use, DCCconcepts Power Bus Tags make the installation of a layout power bus very easy.

**STEP 1:** Cut the eyes of the two outside wiring tags & open them up. We use our DCT-FSC cutters or DCT-FWS strippers for this.



**STEP 2:** Using the DCT-BWS Bus Wire Strippers, separate the insulation on the power bus wherever you need to add droppers (by 7~10mm)



**STEP 3:** Insert the stripped section into the cut eyes of the tags then close them up.

Solder the stripped bus wires to the eye of the tag. They are pre-tinned to make it easy.

**STEP 4:** Pull the bus straight but not too tight and then secure the tag where you wish to fix it with a short screw (we use #6 flat or pan head)

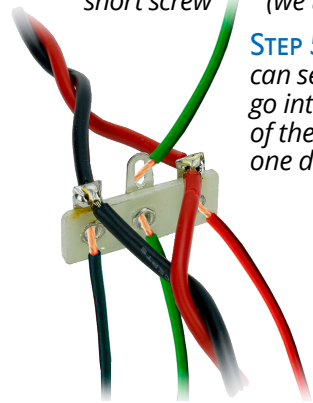

**STEP 5:** Add the droppers. As you can see from the picture these can go into the eyelet holes on each of the tags. You can fit more than one dropper into each of them.

If there are turnouts in the area you can use the centre tag for the frog wires. One wire to the turnout frog and the other to the switch on your Cobalt turnout motor.

## NEEDFUL THINGS... TO HELP YOU WIRE THE LAYOUT

### MAKING LAYOUT CREATION EASIER

Many modellers do not enjoy wiring their layouts.

This is a shame because it is one step that, if you do it correctly, will ensure that you can enjoy consistent and reliable running after all of the hard work is done.

More often than not, this happens because the right techniques aren't explained or understood, or, of course, because the right tools for the job may not be to hand.

We've tried to help with both in this catalog, as we know how easy it all can be when you are properly prepared.

We recommend that you take the time to get it right, and we are quite certain that if you choose the right wire and use the tools offered on this page - it will be easier to do.

(We also invite you to contact us for advice if there are things related to building your layout that still cause you problems)

### FINE WIRE STRIPPERS

A TOOL USED BY PROFESSIONALS TO WORK WITH THE FINEST WIRE

**DCT-FWS ~ Fine Pre-Settable Wire Strippers**



with a set range that goes as low as 0.1mm these strippers are ideal for all fine wiring work.

They have a very sharp cutter between the blades V-Grooves to let you trim wiring precisely.

### BUS WIRE STRIPPERS

SAVE YOURSELF LOTS OF TIME AND FRUSTRATION WITH THIS TOOL!



**DCT-BWS ~ TOP QUALITY ONE-STEP BUS WIRE STRIPPERS.**

There are similar products out there but none are made to this quality... We guarantee them!

Fully adjustable, these strippers cope with wire from dropper-size up to heavy power bus wire.

They can separate insulation in the middle of the wire so you do not ever need to cut the power bus, or just strip the end ready to insert it into a terminal.

A "must have" tool that all modellers will love.

### SUPER-SHARP TRACK CUTTERS

CUT NICKEL SILVER RAIL EASILY AND CLEANLY TIME AFTER TIME

**DCT-XTC Track Cutter** DCCconcepts track cutters cut flush & they are very sharp for a nice clean cut in the rail.



Note the inset image below - this is the correct way to use them



## BASEBOARD ALIGNMENT DOWELS

HYPER-ACCURATE COMPUTER DESIGNED ALIGNMENT DOWELS

**DCB-BDKIT** ~ TWO PAIRS OF DOWELS PLUS THE DRILL BITS THAT YOU WILL NEED TO INSTALL THEM. (ENOUGH FOR TWO BASEBOARDS)

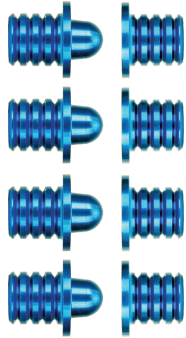
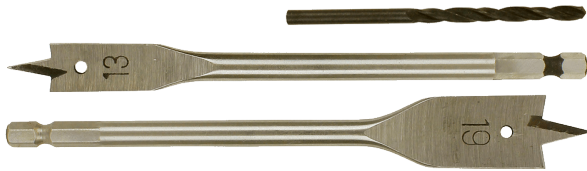
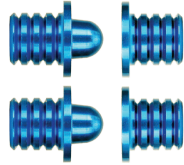

**DCB-DWL** ~ FOUR PAIRS OF DOWELS, ENOUGH TO HELP YOU TO ALIGN THREE BASEBOARDS.

*These Dowels are easier to install accurately than others... They are hard alloy, heavily passivated for zero corrosion and a very long life.*

*Manufacturing tolerances are very fine and there is NO baseboard movement possible once installed.*

*4 pairs will be enough to make two baseboard joints (to join 3 boards)*

## NEEDFUL THINGS... TO HELP YOU BUILD AND MAINTAIN

MORE ITEMS AT [WWW.DCCCONCEPTS.COM](http://WWW.DCCCONCEPTS.COM)

### THE JUMBO TRACK CLEANER

A GREAT VALUE TRACK CLEANER THAT ACTUALLY POLISHES THE RAILS



DCT-TCB Track Cleaner

*It is BIG (more than 8 x larger in area than any other track cleaner).*

*Our TCB track cleaner is also the very best there is as the Aluminium Oxide particles polish the rail without scratching and a pure rubber base means it is easy to wash clean.*

## TRACKWORK RELATED GAUGES

SUPER-ACCURATE TRACK GAUGES TO HELP YOU IMPROVE RESULTS

*You may not need all of these - but look at them all so you are aware they exist, because if there IS a problem, they may well be the tool you need to help you to solve it!*

**BACK-TO-BACK GAUGES** **DCG-BB145** for OO and HO standard wheelsets  
**DCG-BBN** for standard N scale wheelsets



*There are some specialised gauge sizes too - please see our website for the full range.*

**DCG-RGFB100** for standard TRACK ROLLER GAUGES code 100~ OO and HO track

**DCG-RGN9mm** for standard N scale track

*Again, we have them for finer track sizes too - please see our website for the full range.*



**THREE POINT GAUGES** **DCG-TGOO** for most of the 16.5mm OO & HO track types



**DCG-TGOOSF** For those who wish to make their own track to OO-SF standards (*This is also the best choice for those running RTR locos and stock.*)

## ETCHED COPPER-CLAD SLEEPERING

PRE-CUT AND ETCHED SLEEPERS READY TO HOLD THE RAIL ENDS

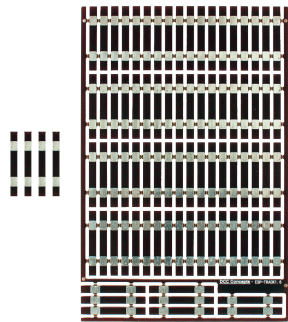

**ESP-TRACK1.6** Etched and pre-cut / pre-tinned sleepers. OO/HO Sleepers for fixing the track down at baseboard ends.

*They are ready to use with no need for you to clean up or cut gaps in the copper.*

*The fret contains 80 sleepers for plain track, each sleeper is 1.6mm thick and 32mm long.*

## CLOSED-CELL LONG LIFE TRACK BED

5MM OR 3MM THICK, SHEET OR STRIP, OO/HO & N SCALE TOO

**DCU-TBH5** ~ HO/OO STRIPS 5MM THICK, 33M IN A BOX

**DCU-TBH3** ~ HO/OO STRIPS 3MM THICK, 33M IN A BOX

**DCU-TBN3** ~ N SCALE STRIPS 3MM THICK, 33M IN A BOX

**DCU-TBS5** ~ SIX SHEETS 5MM THICK, EACH 600x300

**DCU-TBS3** ~ TEN SHEETS 3MM THICK, EACH 600 x 300

*Strips are pre-split on the rear to help you to lay them to a centre-line.*



## LEGACY BALLAST. (EMAIL US, ASK FOR A SAMPLE)

ACCURATELY SIZED, ARTFULLY BLENDED FOR BEST RESULTS



**LB-4BB** OO/HO Brown aged ballast blend

**LB-4SE** OO/HO Shed and Steam Era blend

**LB-4LG** OO/HO Grey newer ballast blend

**LB-2BB** N~2mm Brown aged ballast blend

**LB-2SE** N~2mm Shed and Steam Era blend

**LB-2LG** N~2mm Grey newer ballast blend

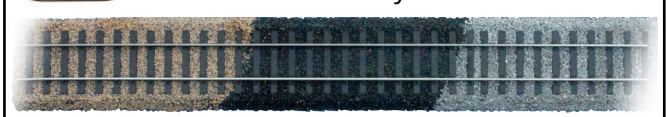

## REMOVING THE PECO SPRINGS...

WHEN USING MOTOR-DRIVE POINT MOTORS LIKE COBALT, THE SPRINGS ARE NO LONGER NEEDED & REMOVING THEM WILL IMPROVE RELIABILITY.

YOUR POINTS WILL ALSO LAST MUCH LONGER WITHOUT THEM!

### How do we know that this is true?

We do this with turnouts used in our Cobalt motor life tests. Reliability matters as tests exceed 200,000 changes.

If we leave the springs in, they often fail during the tests and important parts like blade to tie-bar connections will also tend to fail at around 40,000 change cycles.

This is because of wear from the "Snap Action" and it can happen much earlier if we are testing with solenoids.

But - if we take the springs out and use Cobalt motors which are very gentle, we get a huge lift in reliability.

An extreme example: one Cobalt life-test unit (the one shown top right on page 15 of this catalog) has had the same turnout in place for nearly a million change cycles!

This is a credit to both the gentleness of Cobalt motors AND to the Peco code 75 point fitted to the test unit!

### THIS IS HOW IT IS DONE

(IT IS EASY TO DO AND WILL NOT HARM THE POINT)

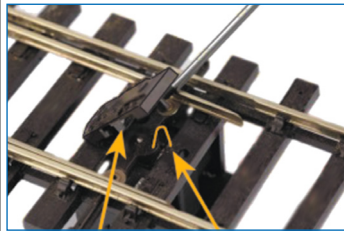

For points with a plastic pin holding the cover on.

- \* Lever up the cover
- \* Remove the spring
- \* Replace the cover

The added arrows will help to make the whole process clearer for you.

For points with metal clips to hold the spring cover on.

- \* Lever up the metal tabs and remove the cover
- \* Remove the spring
- \* Replace the cover

We hope that the arrows will help to make the process quite clear and easy for you.

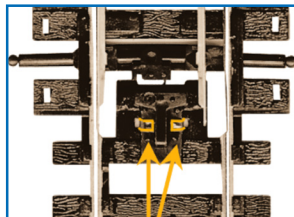

## HELPFUL THINGS...

### THAT EVERY MODELLER SHOULD KNOW

LOTS MORE ADVICE AT [WWW.DCCCONEPTS.COM](http://WWW.DCCCONEPTS.COM)

## MAKE THE MOVE TO CODE 75 RAIL

TRAIN-SETS COME WITH CODE 100 SO MANY CONTINUE IT... BUT IT IS A BIG COMPROMISE IN REALISM WHEN YOU BUILD A LAYOUT.

The picture below tells the story better than words...

Code 100 track is simply far too heavy and with the rails (for OO) already too close together, this heavy look is emphasised, so Code 75 rail just looks so much better.

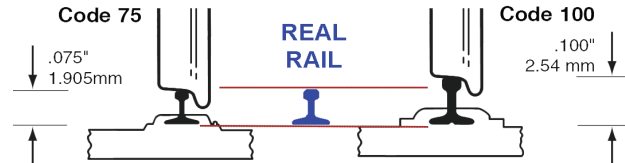

Code 75 is quite robust so if you are building a layout you will see no difference in track life or wear rates.

Flange size of wheels is not an issue and all except very, very old (40 years+) models will run nicely on it.

There are however some things that changing to Code 75 track will make very much easier for you...

\* Code 75 Flex track and rail bend more naturally and they form nicer joints on curves because the rail is less stiff.

\* Code 75 rail has less than 50% of the cross-section of Code 100 so it cuts more cleanly with much less effort.

And... there will be NO waste in making the change. You can relegate the Code 100 to the fiddleyard because joining Code 75 to Code 100 is actually quite easy.

Simply use Peco transition joiners or just file away the top part of the Code 100 rail and solder the Code 75 to it.

## PROPER WIRING FOR ELECTROFROG

AS YOU BUY THEM, PECO POINTS ARE READY TO INSTALL, BUT A FEW MINUTES SPENT RE-WORKING THEM WILL REALLY IMPROVE LONG TERM RELIABILITY BY REMOVING DEPENDENCY ON BLADE-TO-RAIL CONTACT!

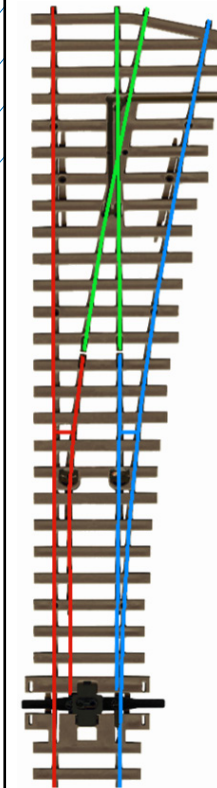

A few minutes making some easy changes to your point-work will guarantee better reliability and running qualities long-term.

The picture to the left shows the result of the changes, and the process is detailed below.

Once done, there will be no more reliance on "Blade-to-rail" contact so trains that stop or stall at points will become a thing of the past.

JOIN the closure rails to the stock rails with small wire links (solder across underneath the rail)

CUT these links to totally isolate the entire frog area from the stock and closure rails

FROG Wire. Connect it to the frog switch on a Cobalt, an ADS Accessory decoder or a similar device with frog-switch ability.

DON'T FORGET to add gaps or insulated rail joiners here when installing the point on the layout.

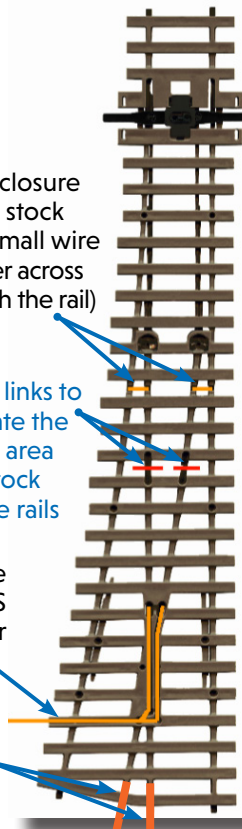

# NEVER HAVE ANOTHER POINT-BASED DERAILMENT!

THE ADDED SWITCHING ON DCC CONCEPTS PRODUCTS SUCH AS COBALT & ADS DECODERS GIVES YOU THE OPPORTUNITY FOR EASY INTERLOCKING OF TRACK POWER SO THAT YOUR YARD USAGE ALL STAYS TOTALLY IN CONTROL

### ADD LEDs TO SHOW THE LIVE TRACK

JUST CONNECT THEM ACROSS EACH LOOP TRACK IN THE EXAMPLE BELOW

The added diode will protect against reverse voltage when wired to DCC. Connect this across the tracks wired as below and only the LIVE track will have an illuminated LED

## SIMPLE INTERLOCKING TO CREATE SAFE POINTWORK & 100% ERROR-FREE OPERATION OF HIDDEN STORAGE YARDS

TRAINS THAT ARE RUN ACROSS POINTWORK SET AGAINST THEM & CONFUSION WITH TRAIN MOVEMENTS IN HARD-TO-SEE AREAS ARE THE CAUSE OF MOST FRUSTRATION, DERAILMENTS AND SHORT CIRCUITS ON ANY LAYOUT. USING THE SWITCHES THAT ARE ALREADY PROVIDED WITH YOUR COBALT IP AND COBALT-SS POINT MOTORS, ADS, COBALT REX OR SIMILAR OTHER DEVICES CAN END THESE PROBLEMS AND IMPROVE YOUR OPERATING QUALITY.

**LEFT side motors allocate the power. RIGHT side motors reconfirm track change and deliver the power.**

You could actually use only the left-side motors to do all this, but for the sake of only four more wires running the length of the yard, you can be 100% certain that the point motors at BOTH ends of the loops have definitely changed before track power turns on.

When wiring this way, please make sure that the 4 long (orange) wires in particular are reasonably large - no less than 32 x 0.2mm or larger wire as they provide the track power.

This is easier than it looks (Think vertically not left & right when you look at track and wires)

We have isolated the TOP rail of each of the tracks in the yard. (Red small arrows).

We control power to that rail by linking it via the point motors that lead to that rail.

The motors will work together to change which loop or track in the yard is active.

We therefore use the switches on the motors to cascade the connection between them.

Effectively the power wire for the top rail runs via the switches which are all in series.

LEFT side motor switches hand the power up or down the yard ladder depending on their position and the RIGHT side motors actually connect it to the track.

On the first 3 left side motors, the options are "Connect or pass on upwards". The top motor switch is not needed

On the first 3 right side motors the options are "connect the rail or leave it turned off".

On the top right hand motor the option is "which of the last two tracks receive power".

Give it a try. You will not be disappointed. You can use this same idea to protect ALL points!

## THINGS TO THINK ABOUT...

THESE COME FROM CUSTOMER SERVICE AND APPLY EQUALLY TO NEW AND EXPERIENCED MODELLERS

More often than not, we can answer customer enquiries or fix the odd problem very simply. In fact, the answer is generally right there all the time & the modeller really only needed us to provide a little guidance.

We are here to help, but some errors can cause damage. Here are a few thoughts that just may save you a little frustration - or prevent the odd "accidental error".

### General problems:

Generally REAL problems with products are very rare, with most users having none at all. However there is a consistent and interesting pattern among the few who DO have them.

*It has nothing to do with being an experienced modeller or not - while half of the problems come from newer modellers, an equal amount are had by those who consider themselves "old hands"!*

*What is more, MOST are simply caused by not following instructions. Perhaps terminology might confuse new modellers and maybe "old hands" just tend to guess or work by habit a little too much. Please DO read the instructions. We do our best to cover all possible issues AND we also write many, many added manuals or diagrams and make them available online to help you.*

*We are also delighted to help on the phone or by email of course, so do not hesitate - and DO let us know if you want more: we enjoy talking to you and want to give good customer service.. and if needed will even create new or special help for you via a PDF diagram or special "how to" video.*

### Not all wires or power supplies are the same...

Of all cases we see of failure or where results are not as expected... more than 95% can be directly traced back to inadequate wiring or problems with power supplies.

- *Modellers have a fixation on 12 Volts but the interesting thing is, it has never been a 12 volt hobby! Measure any DC controller output and the DC terminals labelled 12V will really be 16 or 17 volts... while the 15V AC terminals will inevitably be nearly 19 volts!*
- *Use an appropriate voltage: You will often find suitable regulated power supplies left over from other things in your bottom drawer... many will be in useful lower voltages (3 to 9 volts)*

*Please STOP thinking any old power supply is OK - it is not! As a general guide:*

- *Forget AC totally for all digital control or DCC devices.*
- *A Regulated DC power supply will always be the best possible choice to power anything digital.*
- *DO consider power supply load: Just because it says 5 Amps on the label does not mean you can load it to that level all of the time.. think about - how long would your car or any tool last if you operated them at their limits constantly. An hour or two before failing perhaps?*

We recommend that you do not load ANY power supply constantly beyond 75% loading!

### Accessory Decoder addressing problems:

A common cause of "Accessory addressing confusion" is using the WRONG instructions! Please always use the instructions from the "creators" of the product you are setting up.

*This may sound obvious, but many modellers try to use their DCC controller instructions to set things like "other brand" digital point motors or accessory decoders.*

*DCC may well be made to operate with standards, but ONLY the company who makes the item you want to address actually know how it should be set up - your controller manufacturer does not!*

## THE NICEST 4MM SCALE RAIL-BUILT BUFFER STOP THERE IS!

THIS SEEMED AN APPROPRIATE PLACE TO PUT OUR ILLUMINATED BUFFER STOP - AT THE END OF THE LINE!

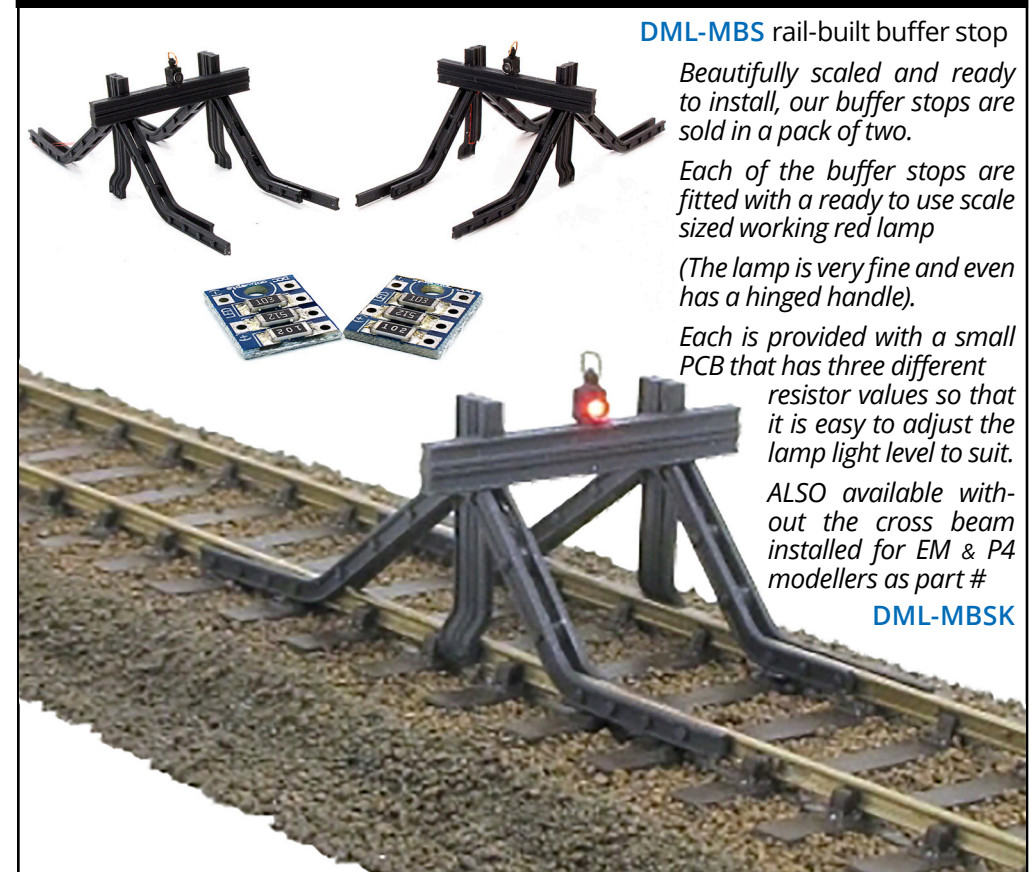

### DML-MBS rail-built buffer stop

*Beautifully scaled and ready to install, our buffer stops are sold in a pack of two.*

*Each of the buffer stops are fitted with a ready to use scale sized working red lamp*

*(The lamp is very fine and even has a hinged handle).*

*Each is provided with a small PCB that has three different resistor values so that it is easy to adjust the lamp light level to suit.*

*ALSO available without the cross beam installed for EM & P4 modellers as part #*

**DML-MBSK**