

Da: Accurascale <support@accurascale.co.uk>
Inviato: mercoledì 1 maggio 2024 14:51
A: news_in@modellismoferroviario.it
Oggetto: Stocktake find - 37s In Extremely Limited Numbers

accurascale

Stocktake find - 37s In Extremely Limited Numbers



accurascale

After completing a customer order audit and stock take we have found a handful (and we do mean handful) of our award winning Class 37s in stock and have now put them back on sale on the website.

Most are 1x of each running number, so you will need to be fast if you want it!

Check out what we have below.



37001

[Shop now](#)



37602

[Shop now](#)



37605

[Shop now](#)



37606

[Shop now](#)



37607

[Shop now](#)



37609

[Shop now](#)



D6704

[Shop now](#)

Accurascale
60 Windsor Avenue
Dalton House
London
SW19 2RR
United Kingdom

[Unsubscribe](#)

© 2024 Accurascale

Da: Accurascale <support@accurascale.co.uk>
Inviato: venerdì 17 maggio 2024 18:24
A: news_in@modellismoferroviario.it
Oggetto: Our Act Of Pure Defiance; 50149 unveiled

accurascale

Our Act Of Pure Defiance; 50149 unveiled



accurascale

Recently we were able to show you the first decorated samples of our all new Class 50 main range of locomotives. Many of you did ask if we could reveal the Accurascale Exclusive pair of 50007 and 50149, so here is the first, 50149!

Before reading on, please note that this is a well used test sample which will have lots of corrections made on the production models

that modellers will receive, including paint application, printing and general fit and finish. These include;

- That gap*
- Translucent Rf General logo*
- Marker lights should be opaque, tail lights should be red*
- Pick ups will be chemically blackened*



accurascale

50149 History

The second half of the 1980s saw a potential new direction for the Class 50s as passenger work began to dry up. While 1987 brought sad news with the first three examples switched off, Plymouth's Laira depot also outshopped the former 50049 Defiance in the stunning new Railfreight General livery with re-gear CP7 bogies and new 50149 number.



accurascale

The sole member of the Class 50/1 sub class, it was primarily used in the South West on china clay and Speedlink wagonload duties before the project was cancelled. This was partially due to poor wheelslip protection and lack of sanding equipment, both ironically removed during refurbishment and considered too expensive to reinstate. It was returned to standard condition in February 1989 and repainted in the revised NSE scheme.

Anyway, onto the pics!



accurascale



accurascale



accurascale

50149 is due in stock along with the rest of the first production batch of the Class 50s at the end of this year. We still have a limited supply of DC/DCC Ready and DCC sound fitted locomotives left available on pre-order, so if you fancy one make sure you get the order in soon to avoid disappointment.

Looking for an Accurascale train to match? Then check out our ECC CDAs, due later this year and sits perfectly behind Defiance!



BR Class 50 - Railfreight
General - 50149
'Defiance' - Exclusive

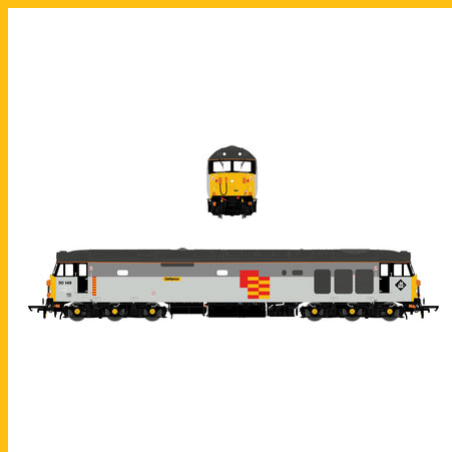

BR Class 50 - Railfreight
General - 50149
'Defiance' - Exclusive -
DCC Sound Fitted

Shop now

Shop now



CDA China Clay - ECC
Blue - Pack A

Shop now



CDA China Clay - ECC
Blue - Pack B

Shop now



CDA China Clay - ECC
Blue - Pack C

Shop now



CDA China Clay - ECC
Blue - Pack D

Shop now



CDA China Clay - ECC
Blue - Pack E

[Shop now](#)

Accurascale
60 Windsor Avenue
Dalton House
London
SW19 2RR
United Kingdom

[Unsubscribe](#)

© 2024 Accurascale

Da: Accurascale <support@accurascale.co.uk>
Inviato: lunedì 20 maggio 2024 14:15
A: news_in@modellismoferroviario.it
Oggetto: 21 tonner stunners - Check out our BR classic mineral wagons

accurascale

21 tonner stunners - Check out our BR classic mineral wagons



accurascale

Our range of 21 ton mineral wagons have been hugely popular since they debuted in our range a couple of years ago.

Since then we have done a whole new production run with all new running numbers and variants.



BR 21T MDO Mineral
Wagon BR Grey Pre-
TOPS - Pack F

[Shop now](#)



BR 21T MDO Mineral
Wagon BR Grey Pre-
TOPS - Pack G

[Shop now](#)



BR 21T MDO Mineral
Wagon BR Grey TOPS -
Pack H

[Shop now](#)



With an additional run of the distinctive Coil A steel carrying wagons too there is plenty for operational interest and all wagons make perfect companions for our first run of early Class 37s along with our forthcoming Class 31s in green and blue, along with railfreight with the MDWs and later coil As.



BR 21T MDW Mineral
Wagon TOPS Bauxite -
Pack A

[Shop now](#)



BR 21T MDW Mineral
Wagon TOPS Bauxite -
Pack B

[Shop now](#)



BR Coil A/SFV Steel
Wagon TOPS Bauxite -
Pack D

[Shop now](#)

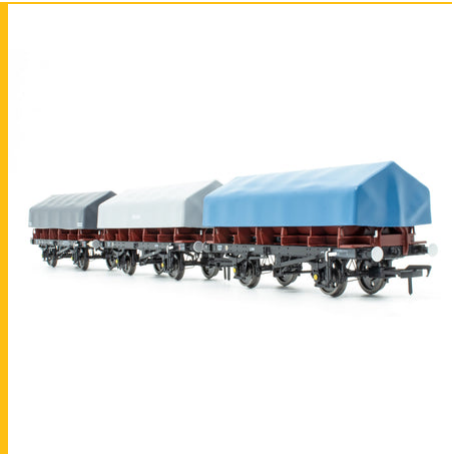

BR Coil A/SFW Steel
Wagon TOPS Bauxite -
Pack E

[Shop now](#)

Priced at just £74.95 per triple pack, with 10% off when you buy two or more packs and an additional 3% cash back with our loyalty points system, they also make perfect sense from a modelling budget point of view. As we always say; realistic models at realistic prices.

Order yours today.



BR 21T MDV Mineral
Wagon Pre-TOPS
Bauxite - Pack F



BR 21T MDV Mineral
Wagon TOPS Bauxite -
Pack G

[Shop now](#)



BR 21T MDV Mineral
Wagon TOPS Bauxite -
Pack H

[Shop now](#)

[Shop now](#)



BR 21T MDW Mineral
Wagon TOPS Bauxite -
Pack A

[Shop now](#)



BR 21T MDW Mineral
Wagon TOPS Bauxite -
Pack B

[Shop now](#)

Accurascale
60 Windsor Avenue
Dalton House

London
SW19 2RR
United Kingdom

[Unsubscribe](#)

© 2024 Accurascale

news_in@modellismoferroviario.it

Da: Accurascale <support@accurascale.co.uk>
Inviato: martedì 21 maggio 2024 14:01
A: news_in@modellismoferroviario.it
Oggetto: Class 66 Driver Packs Now In Stock

accurascale

Class 66 Driver Packs Now In Stock



The ship carrying our first container of Class 66 locomotives has just docked, and we are currently getting unloaded before completing the customs process and heading for our warehouse in the coming days.

Another item that has arrived in stock are our Class 66 drivers, produced in the UK by Modelu.



We have two packs to choose from which can be purchased below for £9.95 per pack. Made specifically for our shed, they are the perfect little detail back to elevate your loco to that next level of realism.

Shop now!



Class 66 Crew -
Driver/Driver -
Privatisation

Shop now



Class 66 Crew -
Driver/Secondman -
Privatisation

Shop now

Accurascale
60 Windsor Avenue
Dalton House
London
SW19 2RR
United Kingdom

[Unsubscribe](#)

© 2024 Accurascale

Da: Accurascale <support@accurascale.co.uk>
Inviato: giovedì 23 maggio 2024 13:55
A: news_in@modellismoferroviario.it
Oggetto: The Class 66 Has Arrived

accurascale

The Class 66 Has Arrived!



accurascale

Great news! The first of our two 40ft containers full of Class 66s has arrived at our warehouse. For a minute we thought it was 66587! It turns out though it was just full of Class 66s.



Unloading is now underway, and we will get right to it for our standard breakdown, checks, picking, packing and shipping in the coming days.



As you can imagine; 2 40ft containers = A LOT of Class 66s, so please as ever afford us some patience to get through them all and get them out to you.

If you have yet to pay for your 66 we advise you do so in the coming days to ensure prompt delivery and no missing out on these beautiful models.

In the meantime, check out some of our in stock wagons below if you want to build your train for your new Class 66! Two packs or more get 10% off, with 5 packs netting you 15% off, along with free UK postage and packaging and 3% cashback with our loyalty points!



MHA - DB - Pack 1

[Shop now](#)



MHA - DB - Pack 2

[Shop now](#)



MHA - EWS - Pack 1

[Shop now](#)



MHA - EWS - Pack 2

[Shop now](#)



FNA-D 'New Generation'
Nuclear Flask Carrier -
Teal - Twin Pack D

[Shop now](#)



PFA - DRS LLNW - 2031
Container Pack 4

[Shop now](#)

FNA-D 'New Generation'
Nuclear Flask Carrier -
Teal - Twin Pack E

[Shop now](#)



PFA - DRS LLNW - 2031
Container Pack 5

[Shop now](#)

Accurascale
60 Windsor Avenue
Dalton House
London
SW19 2RR
United Kingdom

[Unsubscribe](#)

© 2024 Accurascale

Da: Accurascale <support@accurascale.co.uk>
Inviato: venerdì 24 maggio 2024 13:52
A: news_in@modellismoferroviario.it
Oggetto: New Announcement; Finally, the HTO and HTV 21 Tonners In OO/4mm

accurascale

New Announcement; Finally, the HTO and HTV 21 Tonners In OO/4mm



accurascale

There has been a rather large 21 ton hopper shaped hole in our "Powering Britain" range of coal wagons across the history of the railways, and indeed in the British ready-to-run market in OO/4mm market in general.

So, we have pulled our fingers out and now present to you the most requested wagons we have been asked for over the last 24 months; the BR HTO and HTV hopper wagons in original and rebodied formats!

History

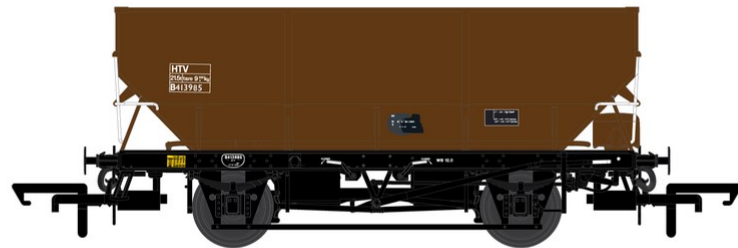
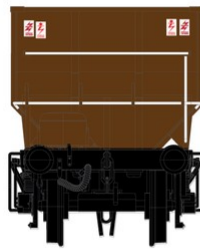
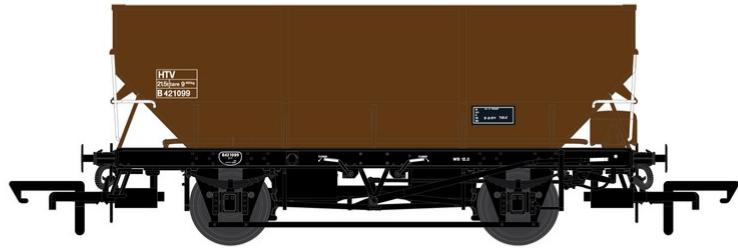
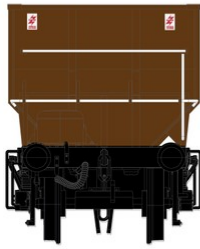

Check out our history blog by Project Manager Steve Purves as he details the history of these widespread wagons, from their LNER origins to their services throughout the BR system all the way into the 1980s, repurposing for departmental use and private owner industrial use by clicking the button below!

[History of the HTO/HTV Wagons](#)

The Model



accurascale

Our first release of this much requested wagon covers the Diagram 1/146 5-rib hoppers in their unfitted guise and the 1/147 and 1/149 rebuilt 2-rib bodies both with and without vacuum braking.

Our tooling suite means we have the ability to fit 4 different styles of axle box to match the prototype wagons, either plate or cast grease 'boxes and SKF or Timken roller bearings.

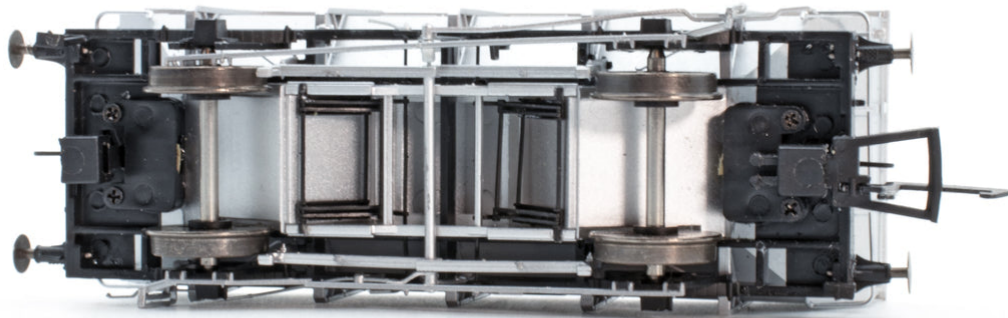

accurascale

In our first release of this much requested wagon, we will cover the Diagram 1/146 5-rib hoppers in their unfitted guise and the 1/147 and 1/149 rebuilt 2-rib bodies both with and without vacuum braking. Their tooling suite means we have the ability to fit 4 different styles of axle box to match the prototype wagons, either plate or cast grease 'boxes and SKF or Timken roller bearings.

Each wagon features a wealth of separately applied detail, from handrails on the diecast chassis and hopper ends to the intricate brake gear and hopper operating mechanism underneath, all museum quality detail and prototypical accuracy modellers now come to expect from our wagons and which is now our standard specification.

When To Expect Them And New "Mega Bundle" Deal



accurascale

With the first engineering prototype models in hand for assessment for some time now, feedback has been drawn up and sent back to the factory, with improved samples with full decoration due in the coming weeks. Delivery of the models to customers is currently estimated at Q3 2025.

The wagons are available in a variety of our now familiar triple packs, featuring both BR freight grey and bauxite liveries, with various running numbers and individual markings as modelled from real photographs of each wagon, allowing modellers to build a prototypical rake. Each pack is priced at £99.95 and we're operating their usual 10% off when you buy two packs or more, along with a new offer of 15% when you buy 5 or more packs direct from their website. That means each wagon just costs £27.47 when you factor in loyalty points rewards and postage and packaging being free!

Pre-order yours today via your local stockist, or no money down below!

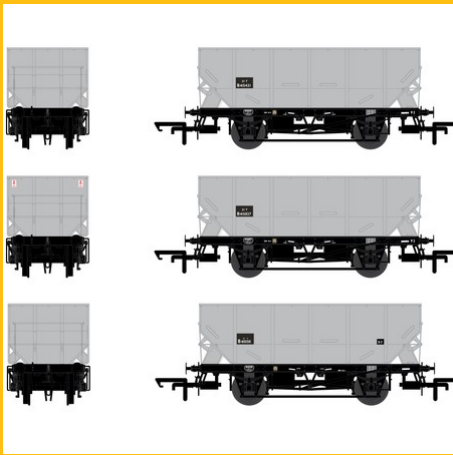

21t - BR Grey - Pack A

Shop now

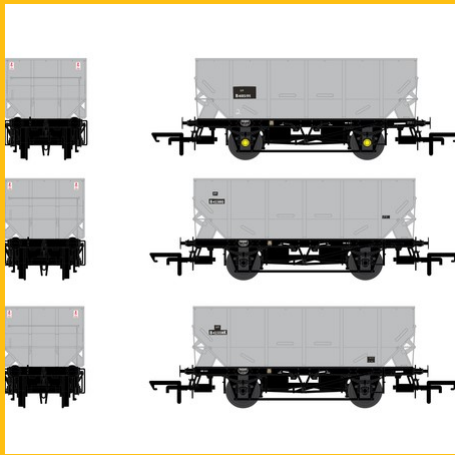

21t - BR Grey - Pack B

Shop now



HOP21 - BR Grey - Pack C

Shop now



HOP21 - BR Grey - Pack D

Shop now



HTO - BR Grey - Pack E



HTO - BR Grey - Pack F

Shop now



HTV - BR Bauxite - Pack
H

Shop now



HTV - BR Bauxite - Pack
J

Shop now

Shop now



HTV - BR Bauxite - Pack
I

Shop now



HTV - BR Bauxite - Pack
K

Shop now



HTV - BR Bauxite - Pack
L

[Shop now](#)



HTV - BR Grey - Pack G

[Shop now](#)

Accurascale
60 Windsor Avenue
Dalton House
London
SW19 2RR
United Kingdom

[Unsubscribe](#)

© 2024 Accurascale

Da: Accurascale <support@accurascale.co.uk>
Inviato: venerdì 31 maggio 2024 14:49
A: news_in@modellismoferroviario.it
Oggetto: Class 66 Accurascale Exclusives Including Charity Fundraiser Now In Stock And Selling Fast

accurascale

Class 66 Accurascale Exclusives Now In Stock And Selling Fast!



accurascale

Great news! Our latest locomotive, the Class 66 has now arrived and we are currently shipping out pre-orders.

In even better news, we have our surplus exclusives, including 66415 "You Are Never Alone" in Freightliner livery, now available to buy exclusively on our website.

Proceeds from the sale of each 66415 goes to the Samaritans, so your new loco purchase also benefits others as well as being a loco you can enjoy for many years to come!

Order below while stocks last!



Class 66 - EWS Maroon
- 66001

[Shop now](#)



Class 66 - EWS Maroon
- 66001 - DCC Sound
Fitted

[Shop now](#)



Class 66 - Freightliner
Orange - 66415

[Shop now](#)



Class 66 - Freightliner
Orange - 66415 - DCC
Sound Fitted

[Shop now](#)

Accurascale
60 Windsor Avenue
Dalton House
London
SW19 2RR
United Kingdom

[Unsubscribe](#)

© 2024 Accurascale