

**Da:** Accurascale <support@accurascale.co.uk>  
**Inviato:** giovedì 1 febbraio 2024 12:03  
**A:** news\_in@modellismoferroviario.it  
**Oggetto:** A Very Manor-ly Birthday

accurascale

## A Very Manor-ly Birthday



accurascale

It's a special day here at Accurascale, as we celebrate our 6th birthday! On Feb 1st, 2018, we revealed our first model, our OO gauge HVO wagons into the market, along with revealing who we are at the same time.

A lot has happened in that time, with four locomotives, two coach types and a staggering 20 different wagons across two scales,

along with commissions for others and accessories delivered in that time, with even more on the way!

One of those locomotives is our beautiful 78xx Manors, which we first revealed on this day three years ago! Delivered last year, we are immensely proud of our first steam loco, and it seems you love it too! We have less than 5% of the total production run left in stock now, so they are becoming an endangered species.

It has also lead to more GWR focused models, such as our Siphon G and Pannier tanks.

So, if you want to see what the fuss is, or don't want to miss out, get your order in below. Remember, all locos are covered by our lifetime "accuracare" warranty along with 3% cashback when you buy direct.

Shop below!



7810 – 'Draycott Manor '  
BR Manor Class

[Shop now](#)



7814 – 'Fringford Manor '  
BR Manor Class

[Shop now](#)



7818 – 'Granville Manor'  
GWR 7800

Shop now



7819 – 'Hinton Manor'  
GWR 7800

Shop now



7824 – 'Iford Manor ' BR  
Manor Class

Shop now



Accurathrash GWR  
'Manor' Loksound DCC  
Sound Decoder

Shop now



GWR 'Manor' Crew -  
Driver/Fireman - BR

Shop now

GWR 'Manor' Crew -  
Driver/Fireman - GWR

Shop now

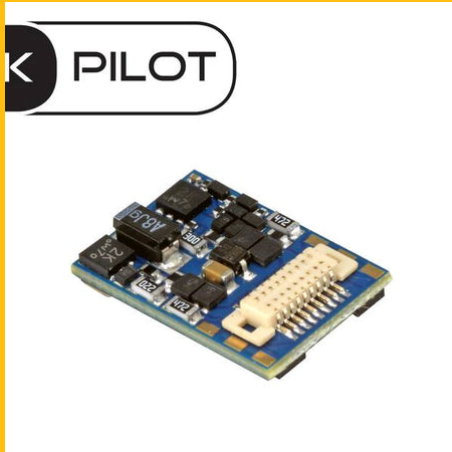

GWR 'Manor' Lokpilot  
DCC Decoder

Shop now



Siphon G - Dia. O.33 -  
BR Carmine Red:  
W2938W

Shop now



Siphon G - Dia. O.33 -  
BR Carmine Red:  
W2977W

Shop now



Siphon G - Dia. O.33 -  
GWR Brown: 2789

[Shop now](#)



Siphon G - Dia. O.33 -  
GWR Brown: 2924

[Shop now](#)



Siphon G - Dia. O.59 -  
BR Maroon: W2982

[Shop now](#)



Siphon G - Dia. O.59 -  
Transitional BR (in GWR  
Brown): W2780

[Shop now](#)

**Pre-Order Your Pannier Here**



5700 Class - 5741 -  
GWR Green

[Shop now](#)

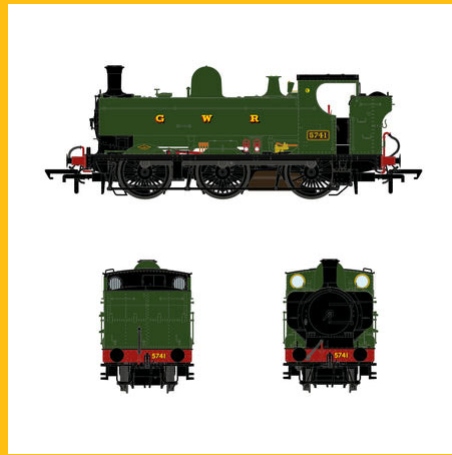

5700 Class - 5741 -  
GWR Green - DCC  
Sound Fitted

[Shop now](#)



5700 Class - 5754 -  
Great Western Green

[Shop now](#)



5700 Class - 5754 -  
Great Western Green -  
DCC Sound Fitted

[Shop now](#)



5700 Class - 7714 -  
Early Emblem Black

[Shop now](#)



5700 Class - 7714 -  
Early Emblem Black -  
DCC Sound Fitted

[Shop now](#)

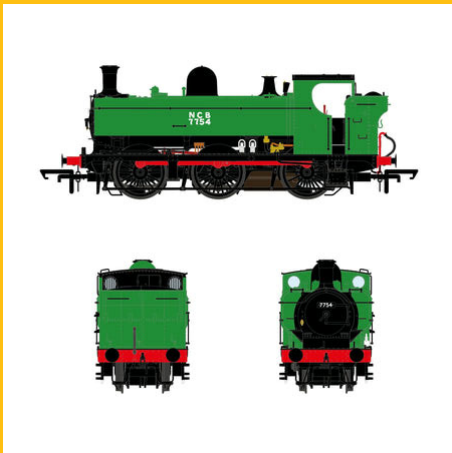

5700 Class - 7754 - NCB  
Green

[Shop now](#)

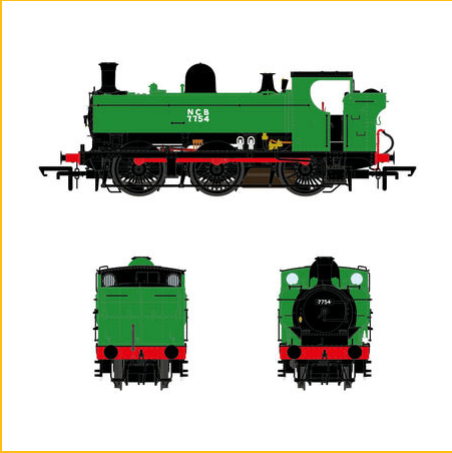

5700 Class - 7754 - NCB  
Green - DCC Sound  
Fitted

[Shop now](#)



5700 Class - 7755 -  
Shirtbutton Green

[Shop now](#)



5700 Class - 7755 -  
Shirtbutton Green - DCC  
Sound Fitted

[Shop now](#)



6700 Class - 6743 -  
Great Western Green

[Shop now](#)



6700 Class - 6743 -  
Great Western Green -  
DCC Sound Fitted

[Shop now](#)





8750 Class - 8763 -  
Early Emblem Lined  
Black

[Shop now](#)

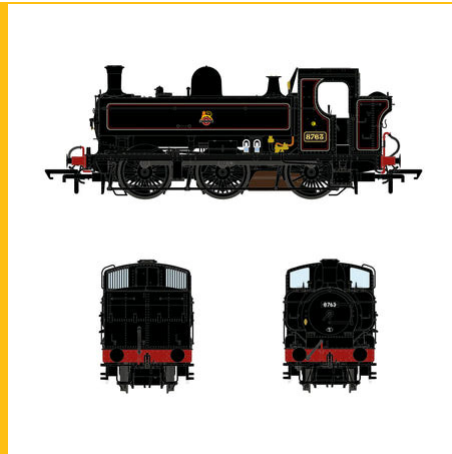

8750 Class - 8763 -  
Early Emblem Lined  
Black - DCC Sound  
Fitted

[Shop now](#)



8750 Class - 9681 - Late  
Crest Black

[Shop now](#)

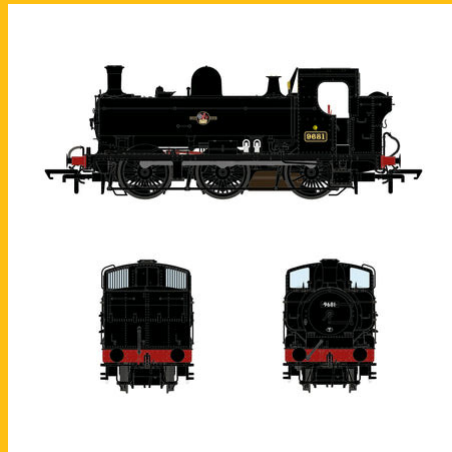

8750 Class - 9681 - Late  
Crest Black - DCC  
Sound Fitted

[Shop now](#)



8750 Class - 9741 -  
British Railways Green

[Shop now](#)



8750 Class - 9741 -  
British Railways Green -  
DCC Sound Fitted

[Shop now](#)

**Accurascale**  
60 Windsor Avenue  
Dalton House  
London  
SW19 2RR  
United Kingdom

---

[Unsubscribe](#)

© 2024 Accurascale

**Da:** Accurascale <support@accurascale.co.uk>  
**Inviato:** venerdì 2 febbraio 2024 12:03  
**A:** news\_in@modellismoferroviario.it  
**Oggetto:** Accurathrash Speakers Back In Stock

accurascale

## Accurathrash Speakers Back In Stock!



accurascale

Great news! Our much loved 4 ohm "Accurathrash" speaker is now back in stock! We also have both lokpilot and DCC sound decoders for our Deltics, Manors and Class 37s in stock too.

So, if you're looking for a simple upgrade of your Accurascale DCC Ready locomotive, check out our range below. With simple plug and play, and easy access, switching your loco to full fat digital sound is a doddle!

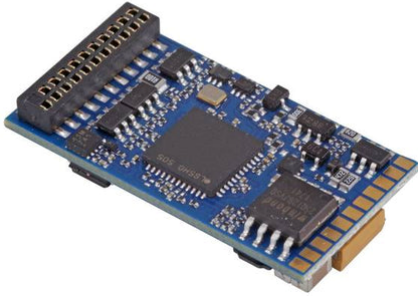

Accurathrash Class 37  
Loksound 'Original' DCC  
Sound Decoder

[Shop now](#)



Accurathrash Class 37  
Loksound 'Refurbished'  
DCC Decoder

[Shop now](#)



Accurathrash Class 37  
Speaker Retaining Clips  
(Pack of 2)

[Shop now](#)



Accurathrash Class 55  
'Deltic' Loksound DCC  
Sound Decoder

[Shop now](#)



Accurathrash Class 55  
Speaker Retaining Clips  
(Pack of 2)

[Shop now](#)



Accurathrash DCC  
Sound Speaker (Pack of  
1)

[Shop now](#)



Accurathrash GWR  
'Manor' Loksound DCC  
Sound Decoder

[Shop now](#)

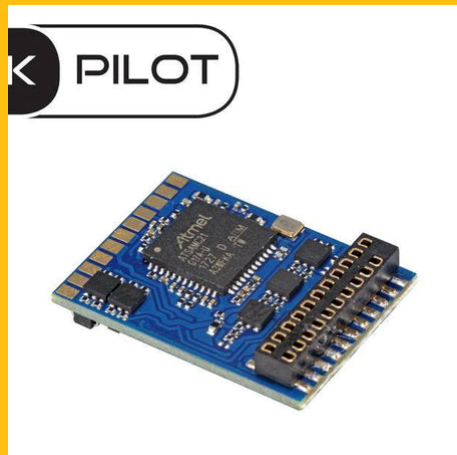

Class 37 Lokpilot DCC  
Decoder

[Shop now](#)

← PILOT

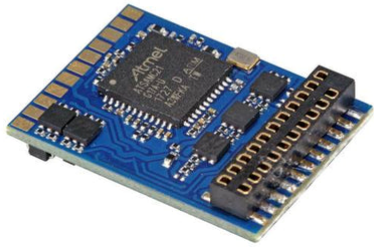

Class 55 'Deltic' Lokpilot  
DCC Decoder

[Shop now](#)

← PILOT



Class 92 Lokpilot DCC  
Decoder

[Shop now](#)

← PILOT

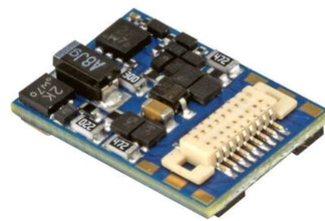

GWR 'Manor' Lokpilot  
DCC Decoder

[Shop now](#)

**Accurascale**  
60 Windsor Avenue  
Dalton House  
London  
SW19 2RR  
United Kingdom

Unsubscribe

© 2024 Accurascale

**Da:** Accurascale <support@accurascale.co.uk>  
**Inviato:** lunedì 5 febbraio 2024 14:04  
**A:** news\_in@modellismoferroviario.it  
**Oggetto:** Rainbow Rustons - Decorated Samples Of Our First O Loco Are Here!

accurascale

## Rainbow Rustons - Decorated Samples Of Our First O Loco Are Here!



accurascale

We first revealed our debut O gauge locomotive at the 2023 GETS show last October, and it certainly raised some eyebrows!

"Accurascale not doing a large mainline diesel? Good heavens!"

Indeed!

The large diesel sector of the O gauge market is very well catered



for, and as a small market, the 7mm side is likely to not withstand two companies competing on the same class of loco. It's also quite new to us, so we said we would go small, cater for layouts large and small, from the sidings of the large empires to the fun shunting planks in the spare rooms around the country and go small, cute and colourful.

Our little Ruston 88DS gives us just that.



accurascale

We're delighted to say that our first decorated samples have arrived for assessment, with one complete model for further testing, and a collection of fully decorated bodyshells to give you a flavour of what's coming soon!



accurascale

As with any product development process, there is a lot to like, and some changes that are required!

So, what do we like so far?

Tampo and overall body paint colours across all liveries are very pleasing.

Some of the highlights include W.M.J.E.A No.1 with its lining and Ruston crest on the cab sides. Our BR Green, and two tone Rowntree Mackintosh lined green and shadowed lettering are also pretty highlights!

Sticking with our green theme, the Bowaters Northfleet 88DS in its Opaline Green and running gear in red, which really stands out and looks very striking.



accurascale



accurascale

The cab interiors are very pleasing, with nice, detailed cab desks. We're also delighted with the weight! They are very, very solid and have a real quality feel to them, with excellent haulage capacity for a locomotive of their size as you will see when we demonstrate them in the coming weeks.



accurascale

Of course, there are areas we can further improve on and correct too. For instance, the yellow that has been applied across the Wasp Stripes and Warning panels is a bit 'thin' on these samples, so the density needs to be increased.

Masking also needs to be improved, but both these issues are normal at this stage and something we have encountered on our OO locomotives at this stage of the process, being fully corrected on the production models customers receive.



accurascale

In places, the excellent fit of the parts has led to that fit being adversely affected by the paint layers; notably on the removable engine panel that covers the PCB which is now too tight and the Donkey Engine panels, which do not sit as flush as they should. Again, this is easily remedied.



accurascale

The glazing panels also suffer from not being cleaned up diligently, which is a common problem on EPs/Deco Samples. Again, this will be corrected for production models. Buffers, Drawhooks and Wheels have not received their chemical blackening, which is normal for this stage, but which does look odd even so. The Panhard Red used on the Tottenham Gas Works 88DS is wrong, but a definitive colour swatch has now been sent, and the red will be adjusted accordingly.



accurascale

Overall, our little Rustons are progressing very well indeed through the design process and are bang on schedule. Sound recording for our digital sound fitted models will commence in the coming weeks and we will look forward to bringing you some footage of the finished sound files once we have them prepared. Delivery is anticipated for Q1 2025.

Pre-order your O Gauge Ruston and Hornsby 88DS today via your local retailer, or direct for no money down via our website by clicking below!

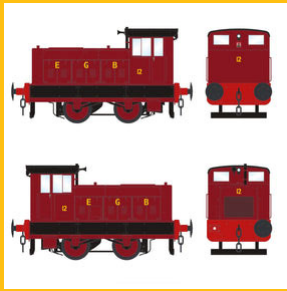

245033/1947 -  
Eastern Gas  
Board -  
Tottenham No.  
12 - Dark Red

Shop now

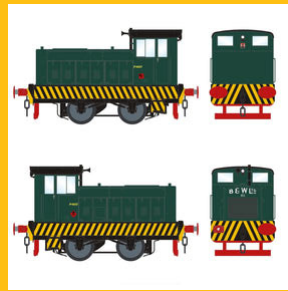

245034/1947 -  
Babcock &  
Wilcox No.  
P4937 -  
Industrial  
Green, with  
Wasp Stripes

Shop now

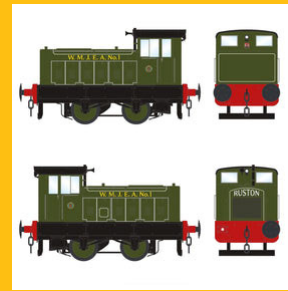

262997/1949 -  
West Midlands  
Joint Electricity  
Authority No. 1  
- Ruston Works'  
Green

Shop now



338413/1953 -  
National Coal  
Board No. 63-  
000-352 - BR  
Rail Blue

Shop now



408493/1957 -  
British Rail No.  
20 - BR Rail  
Blue

Shop now



408496/1957 -  
NEI-Clark  
Chapman -  
Lined Blue, with  
Arrows

Shop now

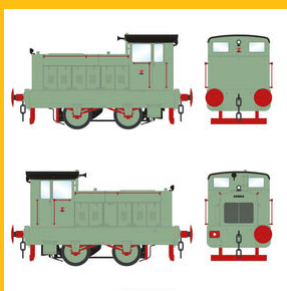

412427/1957 -  
Bowaters  
Northfleet -

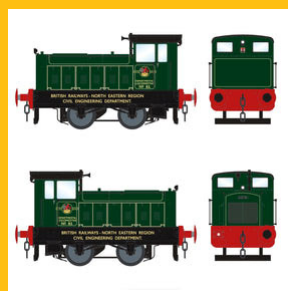

432477/1959 -  
British Railways

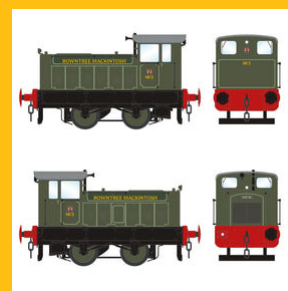

441934/1960 -  
Rowntree

Industrial Pale  
Green

Shop now

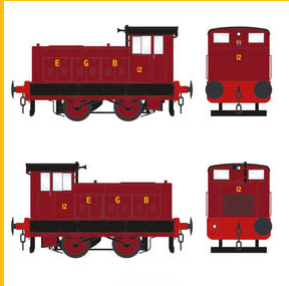

245033/1947 -  
Eastern Gas  
Board -  
Tottenham No.  
12 - Dark Red -  
DCC Sound  
Fitted

Shop now

No. 83 - BR  
Green

Shop now

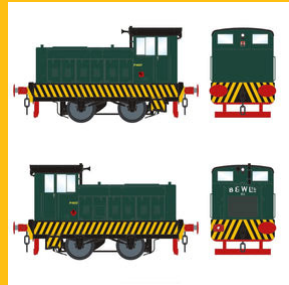

245034/1947 -  
Babcock &  
Wilcox No.  
P4937 -  
Industrial  
Green, with  
Wasp Stripes -  
DCC Sound  
Fitted

Shop now

Macintosh No.  
3 - Lined Green

Shop now

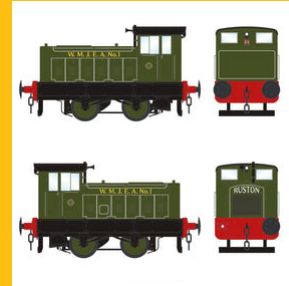

262997/1949 -  
West Midlands  
Joint Electricity  
Authority No. 1  
- Ruston Works'  
Green - DCC  
Sound Fitted

Shop now

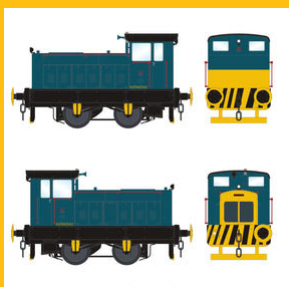

338413/1953 -  
National Coal  
Board No. 63-  
000-352 - BR  
Rail Blue - DCC  
Sound Fitted

Shop now



408493/1957 -  
British Rail No.  
20 - BR Rail  
Blue - DCC  
Sound Fitted

Shop now



408496/1957 -  
NEI-Clark  
Chapman -  
Lined Blue, with  
Arrows - DCC  
Sound Fitted

Shop now



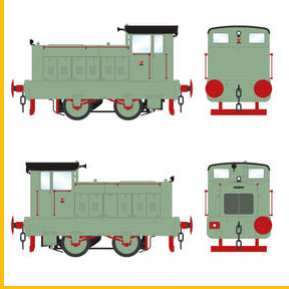

412427/1957 -  
Bowaters  
Northfleet -  
Industrial Pale  
Green - DCC  
Sound Fitted

[Shop now](#)

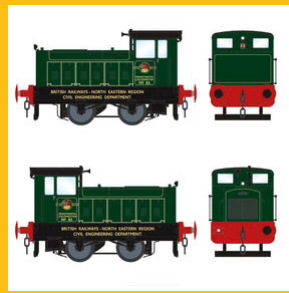

432477/1959 -  
British Railways  
No. 83 - BR  
Green - DCC  
Sound Fitted

[Shop now](#)



441934/1960 -  
Rowntree  
Macintosh No.  
3 - Lined Green  
- DCC Sound  
Fitted

[Shop now](#)

**Accurascale**  
60 Windsor Avenue  
Dalton House  
London  
SW19 2RR  
United Kingdom

---

[Unsubscribe](#)

© 2024 Accurascale

**Da:** Accurascale <support@accurascale.co.uk>  
**Inviato:** martedì 6 febbraio 2024 17:30  
**A:** news\_in@modellismoferroviario.it  
**Oggetto:** We Take On Some Hattons Originals Favourites - Warwells, P and Andrew Barclay Tanks

accurascale

## We Take On Some Hattons Originals Favourites - Warwells, P and Andrew Barclay Tanks



Our hobby has been rocked by the news that Hattons Model Railways, a stalwart in the industry since the 1940s, has decided to close their doors for the last time. The familiar parcels wrapped in twine that many of us remember for many years have gone, along with one of the absolute pioneers of British retail with mail order, online sales and an eye for a shrewd deal along the way.

We may only be around for 6 years now, so we only had the

pleasure of working for Hattons in their very final years. But, what a pleasure that has been, and a relationship that has educated us as well as helped us to preach the gospel that is Accurascale to even more modellers. From top to bottom, they have been fantastic to deal with and we hope that their staff and management go on to have great success in new roles and careers.

But, some of Hattons will live on, and we are delighted and privileged to be able to play a small role in securing their legacy.



accurascale

As you may already know, we acquired the tooling of the Hattons Originals Class 66 locomotives and announced a whole new run with some added Accurascale ingredients at Model Rail Scotland 2023. The production is now almost complete on those locomotives and they ship in mid February.

Utilising that existing relationship with Hattons, we have also been able to secure the future of other "Hattons Originals" toolings, beginning with the OO gauge Warwell wagons, The P Class 0-6-0 tank engine and the Andrew Barclay 0-4-0 tank locomotive. These three models will now join the Accurascale range forevermore! All three models are currently in different stages of production, with Hattons taken pre-orders on all three projects before they closed.

We will update you on each project separately in future, but for now the current status of each project is below;

### **OO Warwells**



The Warwells are complete and will leave the factory in China just after Chinese New Year in late February, landing in stock with us in April 2024. The price of these will be maintained the same as the Hattons price of £25 each. Our bundle deal of 10% if you buy two or more applies along with free UK Postage and Packaging and 3% cashback on all orders. Our new "Accuracare" lifetime warranty will apply to these wagons too!

Trains4u will receive their special limited edition commission as planned. Please contact them for further details on those.

### **Andrew Barclay 0-4-0 ST**

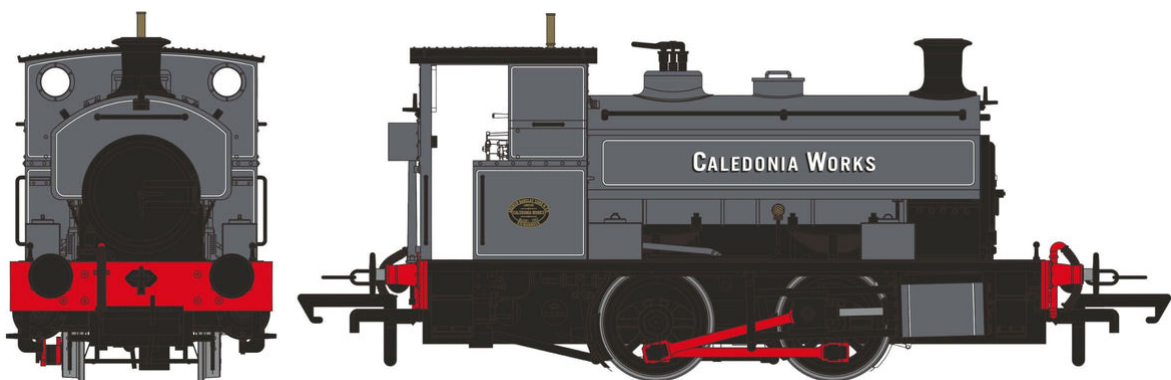

We're delighted to report that these locomotives are at decoration stage which we will reveal in the coming weeks. Production is slated to begin after the Chinese New Year break and delivery will be in Q4 2024.

Unfortunately, with rising costs, the original price of £85 was impossible to maintain, so these locomotives are now priced at £99.95 each. However, with free postage and packaging and 3% cashback on all orders we can still soften the increase with some added value. They will also be covered by our new lifetime "Accuracare" warranty.

### **P Class**



These locomotives are also at the decoration stage which we will also reveal very soon. Production is also slated to begin post Chinese New Year with delivery also in Q4 of 2024. These are likely to arrive after the Andrew Barclay tanks.

As per the Andrew Barclay tanks, the P will also see an increase in price to £99.95, but with free postage and packaging and 3% cashback on all orders we can still soften that increase, along with covering them with our new lifetime "Accuracare" warranty.

### **Your Hattons Pre-Orders**



So, if you have pre-ordered Warwells, P or Andrew Barclay, what happens next?

Hattons will contact you asking if you have any objections with them moving your pre-orders to us. If you do not, then we will need you to register an account on our website and log your payment details for your pre-order. This is so we can safeguard your pre-order so you do not miss out.

If you do not register after 2 weeks, we will consider your pre-order cancelled and we will offer the model for sale to other customers.

### **Next Steps And Placing Pre-Orders**

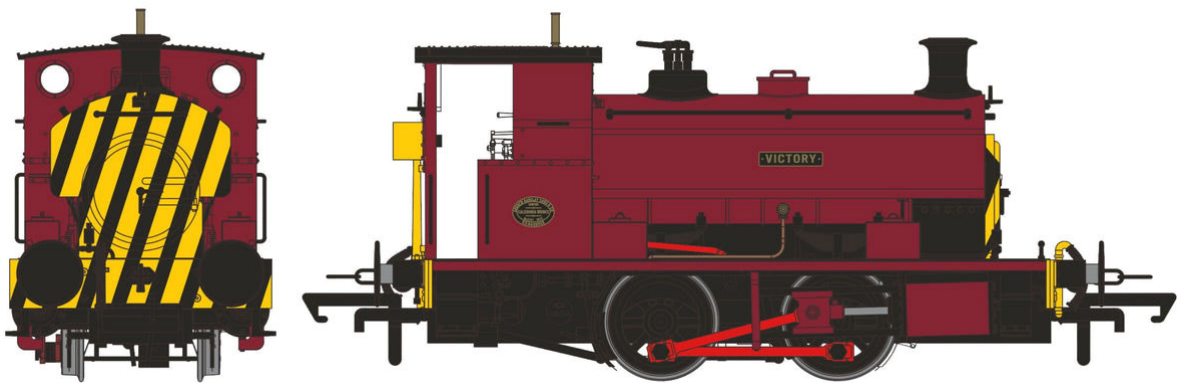

As we are so deep into the production process on the P Class and the Andrew Barclay tank locos we cannot add any further locomotives to the production run, or make any further changes such as offering DCC Sound Fitted options. The specification will remain the same as Hattons originally specified when they first announced this new production run of locomotives. These models will be for sale exclusively on our website only in order to protect historic pre-orders and keep prices as low as we can in line with Hattons.

As mentioned earlier, the commission of Warwells by Trains4u will remain in place and will be delivered to Trains4u in April as planned. Please see them for more information about those models.

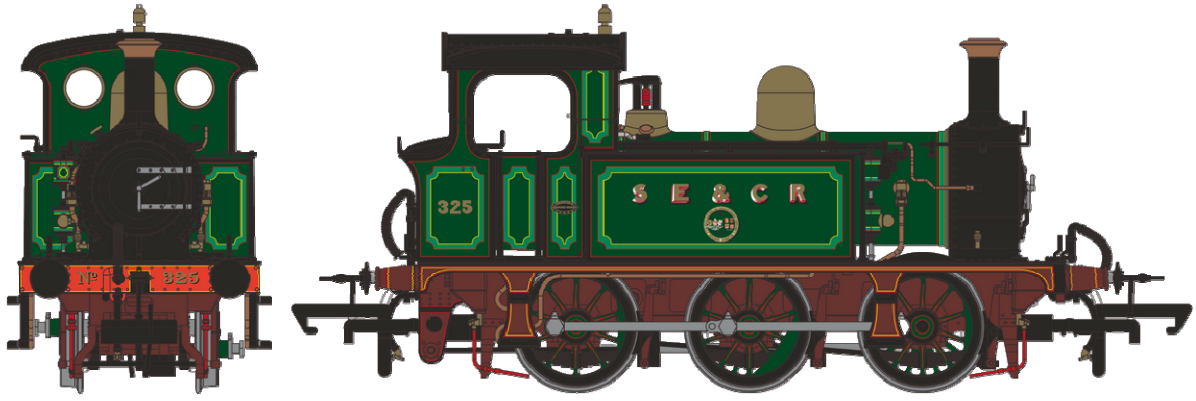

And finally, the question many of you may be asking; what other Hattons Originals models have joined our line up? Well, you will have to keep an eye on us for future announcements later this year and beyond to find out!

[Pre-Order Your OO Gauge Warwell](#)

[Pre-Order Your Andrew Barclay Tank](#)

[Pre-Order Your P Class Tank](#)

**Accurascale**  
60 Windsor Avenue  
Dalton House  
London  
SW19 2RR  
United Kingdom

---

[Unsubscribe](#)

© 2024 Accurascale

**Da:** Accurascale <support@accurascale.co.uk>  
**Inviato:** mercoledì 7 febbraio 2024 13:46  
**A:** news\_in@modellismoferroviario.it  
**Oggetto:** Accurascale Mark 2b Coach Arrival Imminent

accurascale

## Accurascale Mark 2b Coach Arrival Imminent!



Great news! The ship carrying our Mark 2b coaches finally docks this Friday! After taking the long way round due to the unrest caused by Houti rebels, the ship has taken a couple of weeks longer than usual, but finally they are within touching distance of the UK.



Our Mark 2 coaches for sister brand IRM have already arrived in stock and have been met with rave reviews so far, so there is plenty to be excited about.



Our Accurascale coaches are due in our warehouse early next week and dispatch will begin late next week after checks and packing commences.

These have been hugely popular on pre-order, so it will take several days to ship out all orders. We will also have some stock to go back on sale, so make sure you keep an eye on our website in the coming week after pre-order dispatch has begun.

With these now close to delivery, the factory has turned their attention to the Mark 2c variants. These have been in production before Chinese New Year and we will have an update on their progress when the factory goes back to work in the coming weeks.

Many thanks for your patience, and we hope you enjoy these coaches!

[Browse the Accurascale Mark 2b Range Here](#)

**Accurascale**  
60 Windsor Avenue  
Dalton House  
London  
SW19 2RR  
United Kingdom

---

[Unsubscribe](#)

© 2024 Accurascale

**Da:** Accurascale <support@accurascale.co.uk>  
**Inviato:** venerdì 9 febbraio 2024 12:10  
**A:** news\_in@modellismoferroviario.it  
**Oggetto:** Boy From The Black Stuff - Tarmac Ruston 88DS Latest Accurascale Exclusive

accurascale

## Boy From The Black Stuff - Tarmac Ruston 88DS Latest Accurascale Exclusive



accurascale

With our main range of decorated O gauge Ruston and Hornsby 88DS locomotives unveiled earlier this week, we can now unveil our "Accurascale Exclusive" special edition model; 655/29/38 in Tarmac livery!



accurascale

### **The Prototype**

Ruston Works No. 518494 was the last 88DS to be built by the firm, leaving Boultham Works on November 29th 1967 bound for Tarmac Roadstone Holdings Ltd's Southern Division Plant at Hayes, where it was allocated the number 655/29/38 and painted into Tarmac's in-house livery of Olive, with the Tarmac legend and Seven Ts logo being added. There, it joined a 4wDM Hibberd 'Planet', FH3765, which had been at the site since 1956.



accurascale

When the layout at Hayes was revised in June 1967 due to a need to handle increased stone traffic, the 88DS was purchased as FH3765 was not powerful enough for the increased loadings. During the late 1980's, stone began to be delivered in large block trains and the need to shunt wagons ceased. Laid up for a period, 655/29/38 went to the Swanage Railway for preservation on June 29th 1990.



accurascale

The Tarmac numbering scheme is interesting, as the first three digits show the Depot Number, followed by a two digit 'type' number (29 for locomotive in this case) and then the final two digits are the Fleet number. Tarmac's Olive livery remained unchanged between 1966 and 1996 and has been reproduced on the model with help from Tarmac Roadstone Ltd's own Andy Howdle.



### The Model

As outlined in our recent update on the Ruston 88DS range, we are delighted with how our first O gauge locomotive is progressing so far. Naturally, there are a few improvements to be made at this point, including Of course, there are areas we can further improve such as the yellow that has been applied across the Wasp Stripes and Warning panels is a bit 'thin' on these samples, so the density needs to be increased. The buffers, drawhooks and wheels have not received their chemical blackening, which is normal for this stage and will be done on the finished models.



accurascale

Sound recording for our digital sound fitted models will commence in the coming weeks and we will look forward to bringing you some footage of the finished sound files once we have them prepared. Delivery is anticipated for Q1 2025, with this Tarmac model available direct only through the Accurascale website in both DC/DCC Ready and DCC Sound Fitted formats, each coming in the now famous special presentation packaging.

Click on the link below to pre-order yours for no money down today!



518494/1967 - Tarmac  
Roadstone No.  
655/29/38 - Tarmac  
Yellow Olive



518494/1967 - Tarmac  
Roadstone No.  
655/29/38 - Tarmac

[Shop now](#)

Yellow Olive - DCC  
Sound Fitted

[Shop now](#)

## Browse The Rest Of The Ruston Range



245033/1947 - Eastern  
Gas Board - Tottenham  
No. 12 - Dark Red

[Shop now](#)



245033/1947 - Eastern  
Gas Board - Tottenham  
No. 12 - Dark Red - DCC  
Sound Fitted

[Shop now](#)



245034/1947 - Babcock  
& Wilcox No. P4937 -



245034/1947 - Babcock  
& Wilcox No. P4937 -



Industrial Green, with  
Wasp Stripes

Shop now



262997/1949 - West  
Midlands Joint Electricity  
Authority No. 1 - Ruston  
Works' Green

Shop now

Industrial Green, with  
Wasp Stripes - DCC  
Sound Fitted

Shop now



262997/1949 - West  
Midlands Joint Electricity  
Authority No. 1 - Ruston  
Works' Green - DCC  
Sound Fitted

Shop now



338413/1953 - National  
Coal Board No. 63-000-  
352 - BR Rail Blue

Shop now



338413/1953 - National  
Coal Board No. 63-000-  
352 - BR Rail Blue -  
DCC Sound Fitted

Shop now



408493/1957 - British Rail No. 20 - BR Rail Blue

[Shop now](#)



408493/1957 - British Rail No. 20 - BR Rail Blue - DCC Sound Fitted

[Shop now](#)



408496/1957 - NEI-Clark Chapman - Lined Blue, with Arrows

[Shop now](#)



408496/1957 - NEI-Clark Chapman - Lined Blue, with Arrows - DCC Sound Fitted

[Shop now](#)



412427/1957 - Bowaters  
Northfleet - Industrial  
Pale Green

[Shop now](#)



412427/1957 - Bowaters  
Northfleet - Industrial  
Pale Green - DCC  
Sound Fitted

[Shop now](#)



432477/1959 - British  
Railways No. 83 - BR  
Green

[Shop now](#)



432477/1959 - British  
Railways No. 83 - BR  
Green - DCC Sound  
Fitted

[Shop now](#)



441934/1960 - Rowntree  
Macintosh No. 3 - Lined  
Green

[Shop now](#)



441934/1960 - Rowntree  
Macintosh No. 3 - Lined  
Green - DCC Sound  
Fitted

[Shop now](#)

**Accurascale**  
60 Windsor Avenue  
Dalton House  
London  
SW19 2RR  
United Kingdom

---

[Unsubscribe](#)

© 2024 Accurascale

**Da:** Accurascale <support@accurascale.co.uk>  
**Inviato:** martedì 13 febbraio 2024 12:04  
**A:** news\_in@modellismoferroviario.it  
**Oggetto:** Well, Well, Well - A First Look At The Warwells In OO

accurascale

## Well, Well, Well - A First Look At The Warwells In OO



accurascale

Following on from the rather exciting news last Tuesday that we had taken on a number of the Hattons Originals toolings, beginning with the Warwells in OO, The Wainwright P Class and the Andrew Barclay tank engines, we can now bring you the first update on these projects.

We will have news of the Wainwright P Class and Andrew Barclay

tanks in the coming weeks, but first let's look at the production samples of the Warwell wagons in OO gauge!



accurascale

As reported in our announcement blog last week, production of these models is already complete and the models had already been signed off by the Hattons team. We are now responsible for the delivery of these models to market, with any Hattons pre-orders having been transferred over to us and is now logged on our system.

If you have not heard from Hattons, or from us and you do have a Warwell pre-order, please get in touch with us immediately so we can safeguard it for you.



accurascale

We can report that the fit and finish, along with the decoration on these wagons is excellent, and a credit to the Hattons Originals team, making these distinctive wagons really stand out.



accurascale

We can now confirm that these wagons will leave the factory next week for their trip from the Far East to our warehouse in the UK. We envisage them landing with us in April, depending on the continued unrest and shipping disruption in the Middle East.



accurascale

Although some of the running numbers are now sold out, we still have a selection which you can pre-order via our website for £25 per wagon. Click on the link below if you fancy adding some to your fleet, and be sure to check out [Trains4u](#) who have also commissioned two Warwell Wagons in this production run.

*(Please note that this production run is only available direct only from Accurascale to safeguard Hattons Pre-Orders and maintain their original price point of £25, apart from the Trains4u commissioned run)*





50t 'Warwell' military flat with diamond frame bogies in WD livery (LMS variant) - No.57

[Shop now](#)

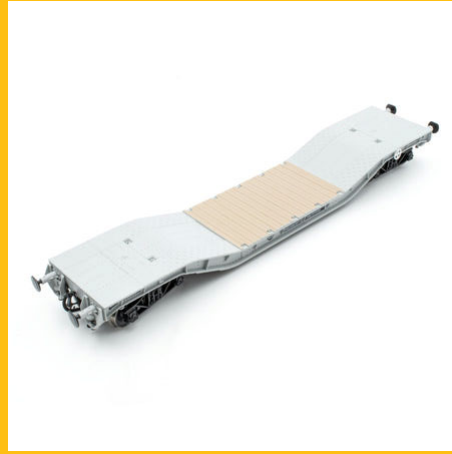

50t 'Warwell' military flat with diamond frame bogies in BR grey - M360335

[Shop now](#)



50t 'Warwell' military flat with diamond frame bogies in BR brown - M360332

[Shop now](#)

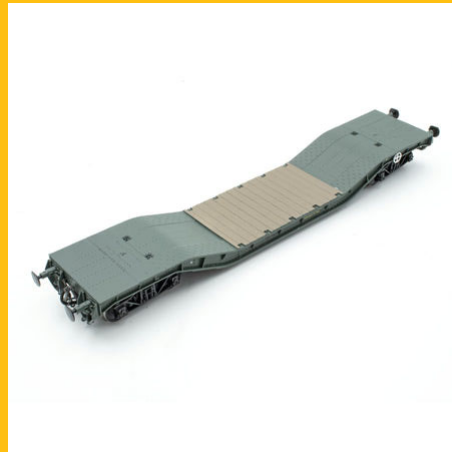

50t 'Warwell' military flat with diamond frame bogies in MOD 1960s green - 83020

[Shop now](#)

**Accurascale**  
60 Windsor Avenue  
Dalton House  
London

SW19 2RR  
United Kingdom

---

[Unsubscribe](#)

© 2024 Accurascale

**Da:** Accurascale <support@accurascale.co.uk>  
**Inviato:** mercoledì 14 febbraio 2024 12:03  
**A:** news\_in@modellismoferroviario.it  
**Oggetto:** Select Class 37s Back On Sale - Move Fast Or Miss Out

accurascale

## Select Class 37s Back On Sale - Move Fast Or Miss Out!



Great news! We have the very last of our first run of Class 37 locomotives back on sale!

Select Class 37/0s and DRS Class 37/6 locos are now available to purchase in very limited quantities, including our Accurascale Exclusive D6703 in special presentation packaging.

Still at the same great price of £169.99 DC/DCC ready and £259.99 DCC sound fitted, along with free UK shipping and 3% cash back,

they also come with Accuracare lifetime warranty like all other past, present and future Accurascale models.

Shop below!



37001

[Shop now](#)



37602

[Shop now](#)



37605

[Shop now](#)



37606

[Shop now](#)



D6702

[Shop now](#)



D6703

[Shop now](#)



D6703 - DCC Sound Fitted

[Shop now](#)



D6704

[Shop now](#)

**Accurascale**  
60 Windsor Avenue  
Dalton House  
London  
SW19 2RR  
United Kingdom

---

[Unsubscribe](#)

© 2024 Accurascale



**Da:** Accurascale <support@accurascale.co.uk>  
**Inviato:** giovedì 15 febbraio 2024 12:13  
**A:** news\_in@modellismoferroviario.it  
**Oggetto:** Andrew Barclay Saddle Tank Decorated Samples Revealed

accurascale

## Andrew Barclay Saddle Tank Decorated Samples Revealed!



accurascale

It's been a colourful few days here at Accurascale Towers, as we have been assessing and evaluating the decorated samples of the Andrew Barclay tank engines which we have taken over following the closure of Hattons.

Following on from our colourful reveal last week of our O gauge Ruston 88DS decorated samples, we're thinking of selling sunglasses so you can cope with this kaleidoscope of colour!



accurascale

Overall, they're excellent and will certainly be up to the very best standards that the Hattons Originals err... original (!) releases were. However, there are some minor corrections that need implementing to get them to those high standards once again.



accurascale



We noted on the NCB locomotive that the buffer shanks need to be black instead of red, and the handbrake centre section should be blue, not black. On the Caledonia Works locomotive, the lining on the cylinders does not extend to the full length of the cylinder, so this will be corrected too. "Efficient" also has some lining quirks which need correcting, including placement on the tank sides, the thickness and again around the cylinder ends.



accurascale



accurascale

On "Victory", the factory have created a sample with the wrong cab windows, the motion bracket is incorrectly painted black and the base of the buffer shanks should be black. We will also be tweaking the shade.

One further change we are looking to make is adjusting the three link chain couplings to give them a slightly more realistic appearance.



accurascale

Overall, these are very minor tweaks required to ready these locomotives for full production, which will now kick off in the coming weeks! This means that the delivery date to customers will be late Q4 of 2024.



accurascale

We are locked into the production run size that Hattons specified with the factory, so there is only a finite amount still available to pre-order. Anyone who has previously placed a pre-order for these locomotives with Hattons can rest assured that their pre-order is safe and has been transferred to us, unless they requested otherwise.

Pre-order yours today, with no money down, directly via the Accurascale website below, for £99.95 per loco.



Andrew Barclay 0-4-0ST  
14" 'Carbon' in NCB lined  
maroon



Andrew Barclay 0-4-0ST  
14" 'Efficient' in lined  
green

Shop now



Andrew Barclay 0-4-0ST  
14" 2201 'Victory' in plain  
maroon with wasp  
stripes

Shop now



Andrew Barclay 0-4-0ST  
14" in Caledonia Works  
lined grey - unnumbered

Shop now

Shop now

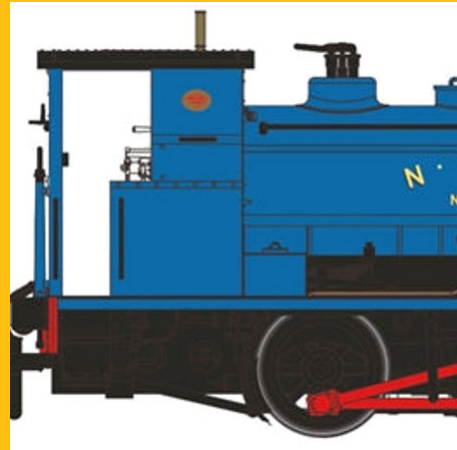

Andrew Barclay 0-4-0ST  
14" 47 in NCB blue

Shop now

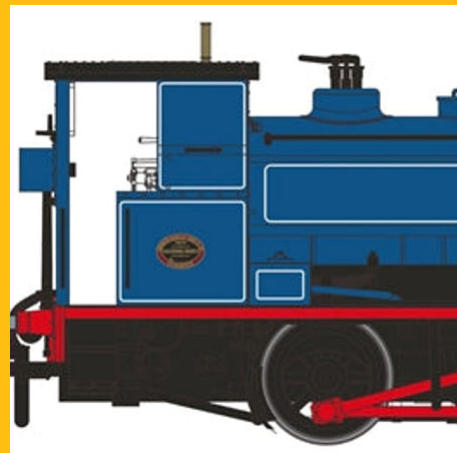

Andrew Barclay 0-4-0ST  
14" in lined light blue -  
unnumbered

Shop now

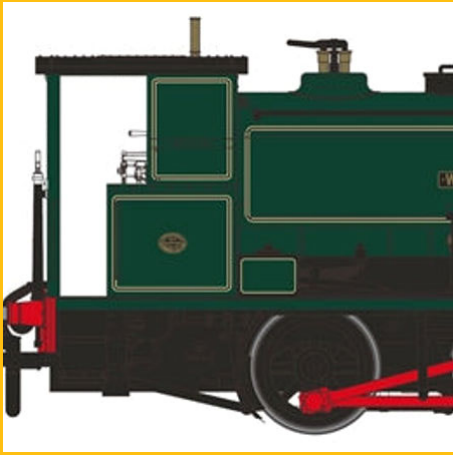

Andrew Barclay 0-4-0ST  
16" 2266 'Wallace' in  
lined green

[Shop now](#)

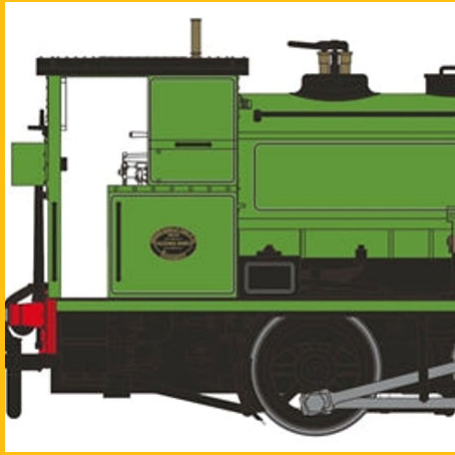

Andrew Barclay 0-4-0ST  
16" in lined apple green -  
unnumbered

[Shop now](#)

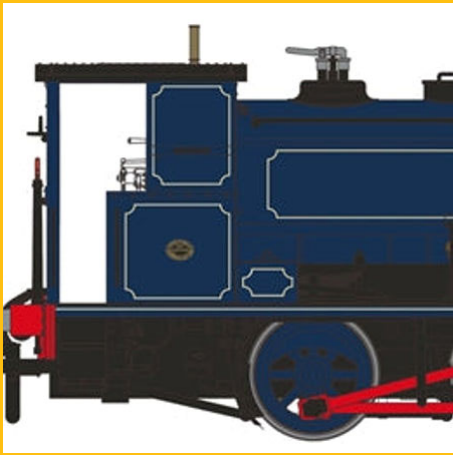

Andrew Barclay 0-4-0ST  
16" in lined dark blue -  
unnumbered

[Shop now](#)

**Accurascale**  
60 Windsor Avenue  
Dalton House  
London  
SW19 2RR  
United Kingdom

Unsubscribe

© 2024 Accurascale

**Da:** Accurascale <support@accurascale.co.uk>  
**Inviato:** venerdì 16 febbraio 2024 13:04  
**A:** news\_in@modellismoferroviario.it  
**Oggetto:** Class 55 Deltic Run 2 Update February 2024 - Decorated Samples Revealed

accurascale

## Class 55 Deltic Run 2 Update February 2024 - Decorated Samples Revealed!



accurascale

It was "55 for 5" this time last year as we announced our second run of Class 55 Deltics to mark our 5th birthday in February 2023.

The mighty Deltic was of course our first Accurascale locomotive, and one that proved to be unwaveringly popular among modellers, with models selling out in record time and a huge demand in place for a second production run.



accurascale

While feedback on the locomotives was resoundingly positive, there was some excellent constructive feedback too relating to some fit and finish problems some modellers had encountered with their models. This centred around some extra detailing parts around the fuel tanks becoming dislodged in transit, the end had rails sticking too far out, our large "Accurathrash" speaker hitting the roof of the locomotive as it powered up on some models and of course, those infamous brake chains on each bogie.

Of course, always wanting to do better, we announced that we would go back to the drawing board with this feedback, and try to do better.





accurascale

All these small issues have now been addressed, with parts being more securely attached with bigger recesses for these parts, the brake chains will now have a new attachment arrangement which makes them more simple to attach and take off for locomotive maintenance, the speaker is now mounted in a lower position in the chassis frame and the handles have been adjusted.

On these decorated samples, the handrails are still too far out, which we have fed back to the factory who will correct them.



accurascale

Overall, these new decorated samples, featuring these small tweaks are looking very impressive indeed! They have once again been hugely popular on pre-order, with many who missed out first time round coming back and bagging a mighty Deltic for themselves, as well as those looking to increase their fleet of these mighty beasts.



accurascale

We are delighted to share these decorated samples with you of the six running numbers that make up run two, including a much demanded return for Porterbrook Purple 9016! Yes, we know plenty hate it, but plenty of others love it too judging by the sales of this stand out member of the class!



accurascale

The Deltics had been originally penciled in to arrive next month, but with the demand for this production run (far beyond what we originally envisaged) and all the production team currently finishing the Class 66 and 37 production runs, they have been delayed slightly. Production is well underway and delivery will now be in Q3 of 2024. We apologise for this delay, but we wanted to make sure that everyone who wanted a Deltic in this production run gets one!

Some Deltics are still available to pre-order, but are close to selling out. Pre-order yours today via the link below, or from your local stockist for the four main range locomotives!

## DCC Sound Fitted



55004 - BR Blue - DCC  
Sound Fitted

Shop now



55013 - BR Blue w/Silver  
- DCC Sound Fitted

Shop now



55020 - BR Blue - DCC  
Sound Fitted

Shop now



9016 - Porterbrook  
Purple - DCC Sound  
Fitted

Shop now



D9018 - BR Green -  
DCC Sound Fitted

Shop now

## DC/DCC Ready



55004 - BR Blue

Shop now



55020 - BR Blue

Shop now



9016 - Porterbrook  
Purple



D9000 - BR Green  
w/cantrail (VXC)

[Shop now](#)

[Shop now](#)

**Accurascale**  
60 Windsor Avenue  
Dalton House  
London  
SW19 2RR  
United Kingdom

---

[Unsubscribe](#)

© 2024 Accurascale

**Da:** Accurascale <support@accurascale.co.uk>  
**Inviato:** lunedì 19 febbraio 2024 15:41  
**A:** news\_in@modellismoferroviario.it  
**Oggetto:** BR Blue and NSE Class 50 Deco Samples Revealed

accurascale

## BR Blue and NSE Class 50 Deco Samples Revealed



accurascale

Great news! We can reveal further decorated samples of our Class 50 have showed up from the factory for assessment. We have now received BR Blue, BR Blue Large Logo with grey roof, and original Network South East liveries.

These arrived with the Hanson and Hall and BR Large Logo with black roof we previewed before Christmas but we've only got around to photographing them now!

As ever, some fit and finish issues are apparent on these samples, such as the headcode glass on D423 and the body to chassis fit on some examples, but these will be corrected on production models that you receive.

Enough talking, more pics!



accurascale





accurascale



accurascale



accurascale



accurascale



accurascale



accurascale



accurascale

As per our previous update, production is now underway with a delivery date of Q4 of 2024 envisaged.

Order via your local stockist, or direct below. Please note that there is limited stock remaining across all running numbers as production is now in full swing!

## DCC Sound Fitted



BR Class 50 - BR Blue -  
50006 'Neptune' - DCC  
Sound Fitted



BR Class 50 - BR Blue -  
D423 - DCC Sound  
Fitted

Shop now



BR Class 50 - GWR  
Green - 50007 'Sir  
Edward Elgar' -  
Exclusive - DCC Sound  
Fitted

Shop now



BR Class 50 - Large  
Logo w/grey roof &  
orange cantrail stripe -  
50021 'Rodney' - DCC  
Sound Fitted

Shop now

Shop now

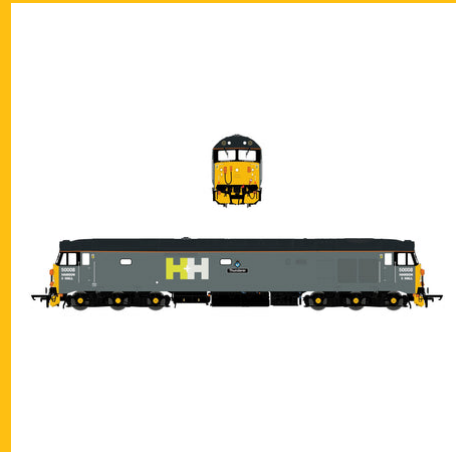

BR Class 50 -  
Hanson+Hall/Rail  
Adventure - 50008  
'Thunderer' - DCC Sound  
Fitted

Shop now

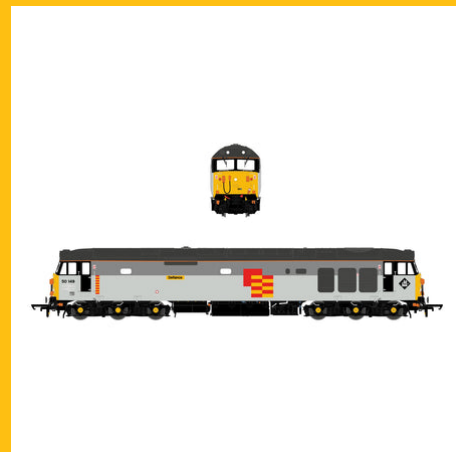

BR Class 50 - Railfreight  
General - 50149  
'Defiance' - Exclusive -  
DCC Sound Fitted

Shop now

## DC/DCC Ready Locos



BR Class 50 - BR Blue -  
50006 'Neptune'

[Shop now](#)

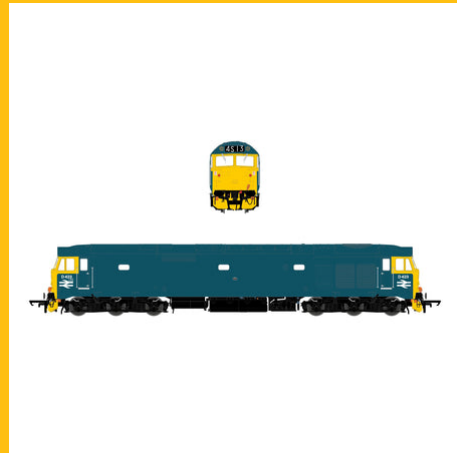

BR Class 50 - BR Blue -  
D423

[Shop now](#)



BR Class 50 - GWR  
Green - 50007 'Sir  
Edward Elgar' -  
Exclusive

[Shop now](#)

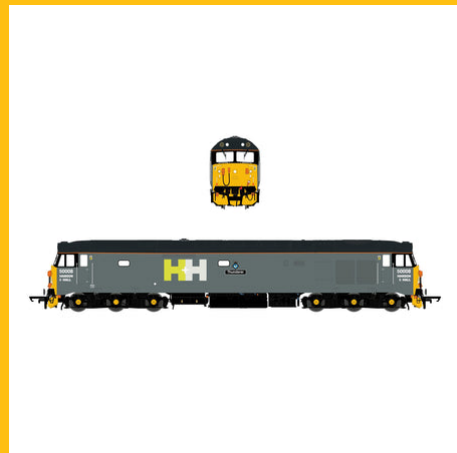

BR Class 50 -  
Hanson+Hall/Rail  
Adventure - 50008  
'Thunderer'

[Shop now](#)

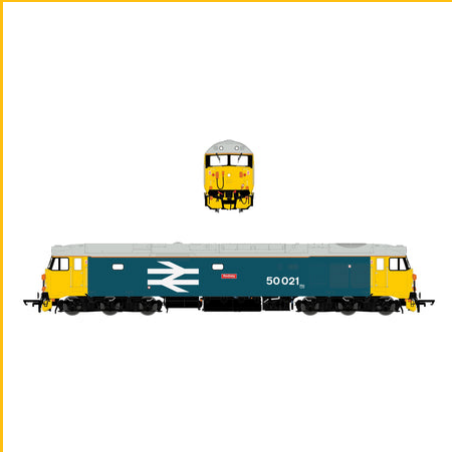

BR Class 50 - Large  
Logo w/grey roof &  
orange cantrail stripe -  
50021 'Rodney'

[Shop now](#)



BR Class 50 - Original  
NSE - 50017 'Royal Oak'

[Shop now](#)

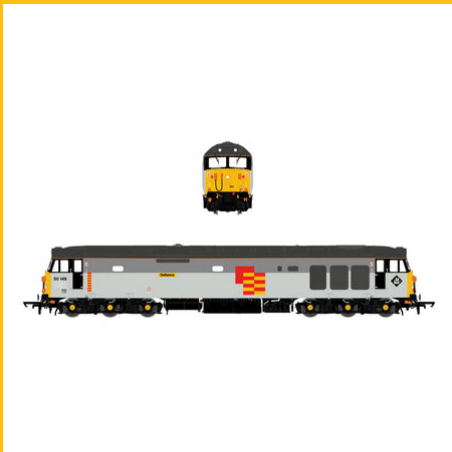

BR Class 50 - Railfreight  
General - 50149  
'Defiance' - Exclusive

[Shop now](#)

**Accurascale**  
60 Windsor Avenue  
Dalton House  
London

SW19 2RR  
United Kingdom

---

[Unsubscribe](#)

© 2024 Accurascale



**Da:** Accurascale <support@accurascale.co.uk>  
**Inviato:** martedì 20 febbraio 2024 12:04  
**A:** news\_in@modellismoferroviario.it  
**Oggetto:** Black Diamond To Technicolour - NER 20T Hopper Decorated Samples

accurascale

## Black Diamond To Technicolour - NER 20T Hopper Decorated Samples!



accurascale

Time for yet another decorated sample update! This time it's one of our wagon projects that has somewhat flown under the radar - The NER 20t coal hoppers, which form an integral part of our "Powering Britain" range of coal carrying wagons across the ages of the railway.



accurascale

Announced just over a year ago our NER hoppers were going great guns until a factory closure derailed (pardon the pun!) progress on these wagons. But, now that the upheaval of swapping factories is passed us, we can now back on track (again, apologies for the pun!) and we now bring you decorated samples of this rather vast range of detail differing wagons.

So, onto the images!



accurascale



accurascale



accurascale



accurascale



accurascale



accurascale



accurascale

Production on these hoppers is now underway and making swift progress following the factory closure and move to another of our factories. Current timeline for delivery is now Q4 2024. We apologise for this slight delay but we were undone by this issue that was completely beyond our control.

Pre-order your NER 20t hopper family today, whether it be NER, LNER, BR or a multitude of industrial liveries via your local stockist or below direct from our website!

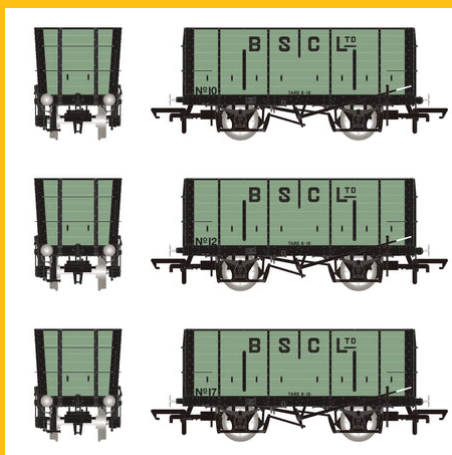

BSC (Internal User)  
Hopper - Pale Green,  
with black ironwork -  
Triple Pack

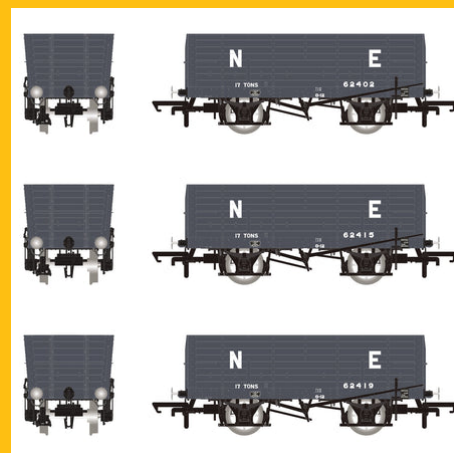

DGM 11 (ex-P6) Hopper  
- LNER Grey - Triple  
Pack

Shop now

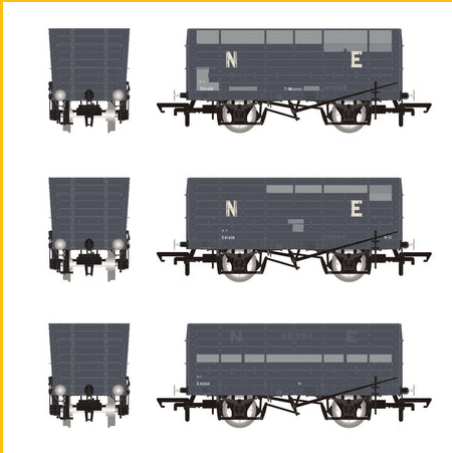

DGM 12 Hopper - BR  
Grey - Triple Pack

Shop now

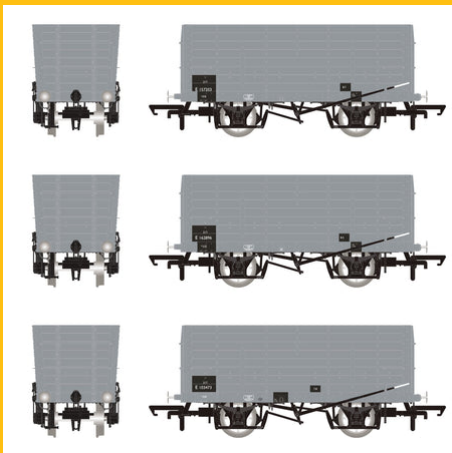

DGM 12 Hopper - BR  
Grey, with black panels -  
Triple Pack

Shop now

Shop now

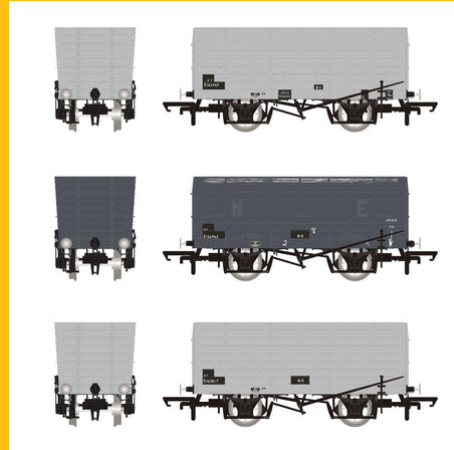

DGM 12 Hopper - BR  
Grey, with black panels -  
Triple Pack

Shop now

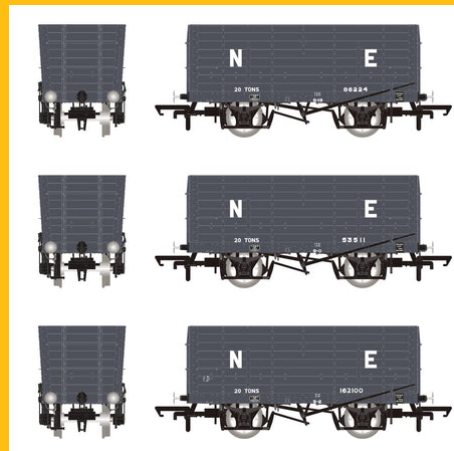

DGM 12 Hopper - LNER  
Grey - Triple Pack

Shop now



DGM 12 Hopper - United Steel Company Grey - Triple Pack

Shop now

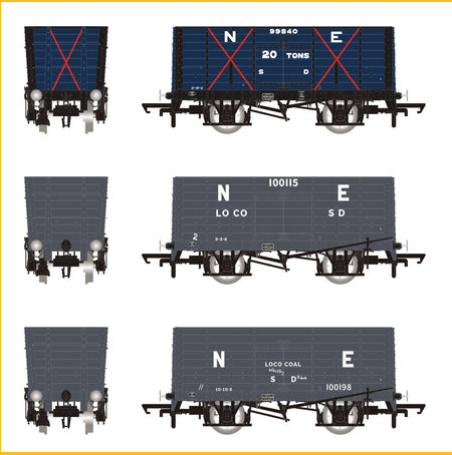

Mixed Q3 Hopper - Grouping transition period: 1910-22 NER Blue/1923-37 LNER Grey - Triple Pack

Shop now

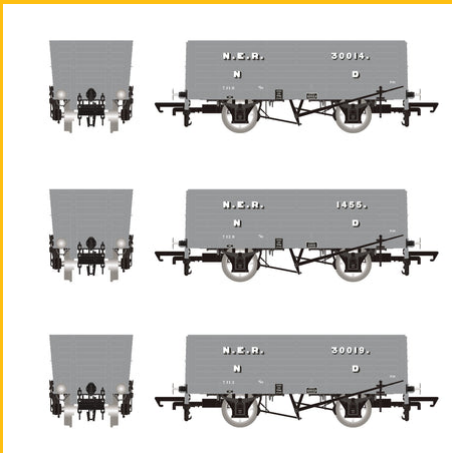

P6 Hopper - 1901-1904 Pre-Grouping: NER Grey - Triple Pack

Shop now



P7 Hopper - 1904-1910 Pre-Grouping: NER Grey - Triple Pack

Shop now



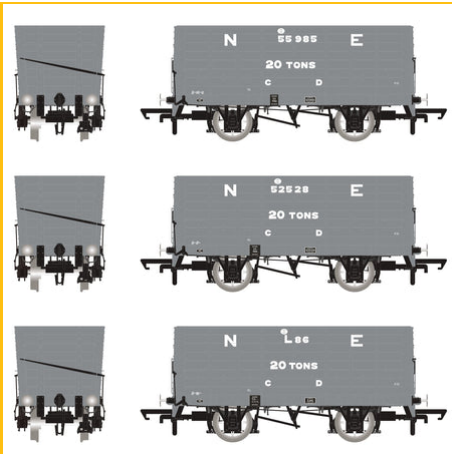

P7 Hopper - 1911-1922  
Pre-Grouping: NER Grey  
- Triple Pack

Shop now

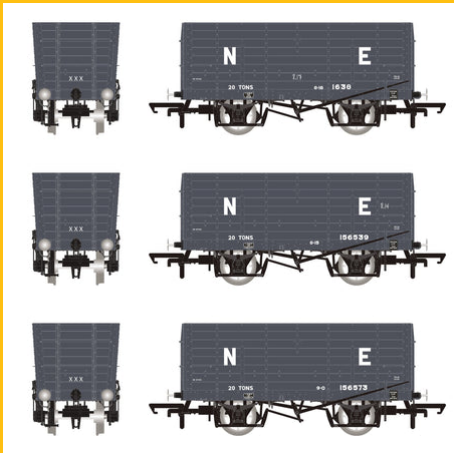

P7 Hopper - LNER Grey  
- Triple Pack

Shop now



P7 Hopper - NCB  
(Brodsworth) Black, with  
white planks - Triple  
Pack

Shop now



P7 Hopper - NCB  
Ashington: NCB Red -  
Triple Pack

Shop now

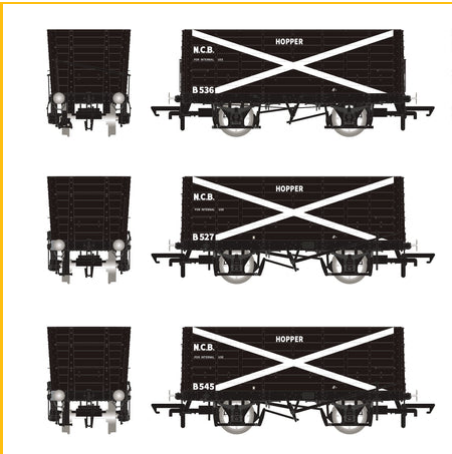

P7 Hopper - NCB Black,  
with white cross - Triple  
Pack

[Shop now](#)

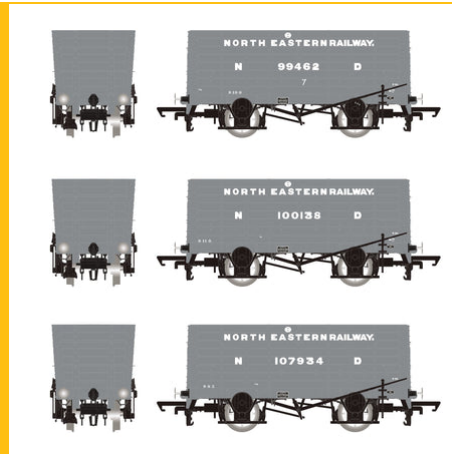

P8 Hopper - 1904-1910  
Pre-Grouping: NER Grey  
- Triple Pack

[Shop now](#)

**Accurascale**  
60 Windsor Avenue  
Dalton House  
London  
SW19 2RR  
United Kingdom

---

[Unsubscribe](#)

© 2024 Accurascale

**Da:** Accurascale <support@accurascale.co.uk>  
**Inviato:** mercoledì 21 febbraio 2024 12:04  
**A:** news\_in@modellismoferroviario.it  
**Oggetto:** New Announcement: Mark 1 Subs In Maroon Unveiled

accurascale

## Mark 1 Subs In Maroon Unveiled!



accurascale

Great news! As our first production run of our stunning new Mark 1 Suburban coaches nears completion, and due to intensive popular demand, we have decided to follow up quickly for the missing link when it comes to liveries for these essential suburban coaches.

So, it gives us great pleasure to present the maroon livery on our BR Mark 1 Subs!

# The Real Coaches



Looking to see if you can justify some maroon Mark 1 marvels on your layout? Check out our blog, where we outline the history of our non-gangwayed stock in our latest blog. Click on the button below to read more!

[Maroon Mark 1 Sub History](#)

## The Model



accurascale

Initially launched in the summer of 2022 after a long development period behind the scenes, our tooling suite of Mark 1 suburban coaches allow modellers to recreate an authentic rake of these workhorses for the first time in ready-to-run format and offered a 21st century rendition of these essential vehicles. Featuring an exquisite level of detail and an unbeatable specification including full interior lighting, fully detailed interior and a museum quality finish, they were offered in BR all-over carmine and BR all-over rail blue.

Only one thing was missing from our launch range; maroon!



accurascale

Thankfully, with the first batch of carmine and blue coaches nearing completion at the factory and are due in stock with us in Q2 of this year, we can turn our attention to the maroon coaches almost straight away.

First up, we have the Midland Region BS, C, S and SO in Maroon, without and without lining. The lined Midland vehicles typically carried their lining lower than the BR spec, to match against the lined Stanier stock.

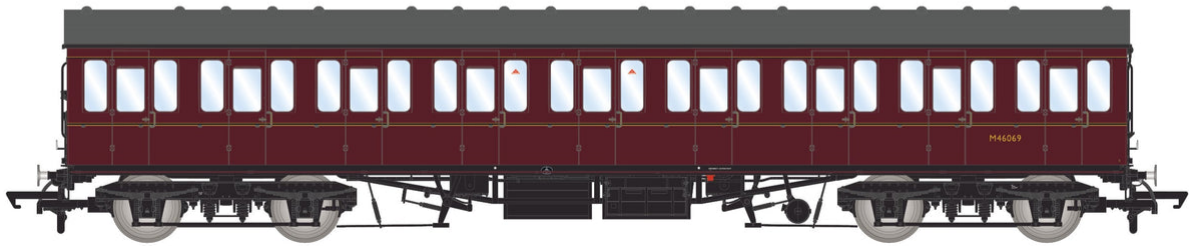
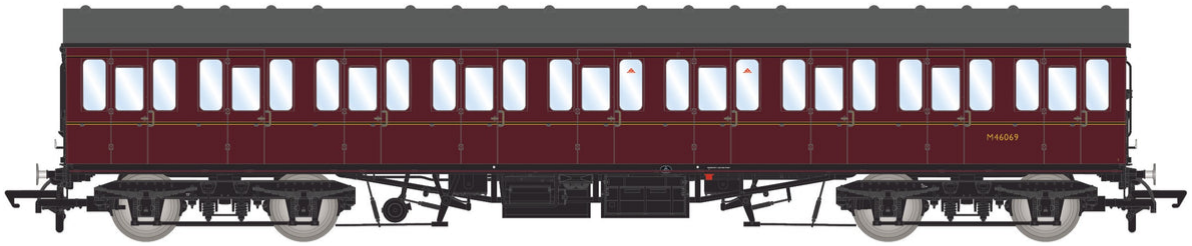
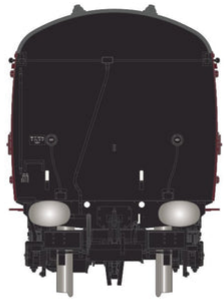

We will also be covering the Scottish Region, with a BS, C and S in Maroon, all lined, but in BR and Stanier positions. Being based on circa 1962 photos, the First Class yellow stripe has now appeared.



## Prices And Availability

Production of these coaches begins shortly, with the decorated samples above provided when we first received samples from the blue and carmine production run (explaining the wobbly foot boards, which will be corrected on production models to be arrow straight!) and delivery will be in Q1 2025. Price will be the same as the first production run at £64.95 each.

Pre-order via your local stockist, or direct via the Accurascale website below, where you can get 10% off when you order two or more coaches!





BR Mk1 57' Non-Gangway Coach - BS - Lined Maroon (Low position) M43235

[Shop now](#)

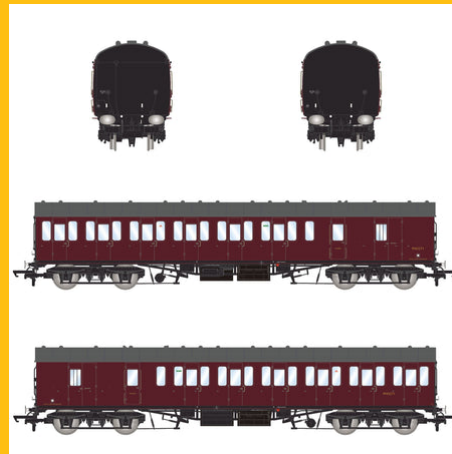

BR Mk1 57' Non-Gangway Coach - BS - Plain Maroon M43271

[Shop now](#)



BR Mk1 57' Non-Gangway Coach - C - Plain Maroon M41000

[Shop now](#)



BR Mk1 57' Non-Gangway Coach - C - Plain Maroon M41001

[Shop now](#)

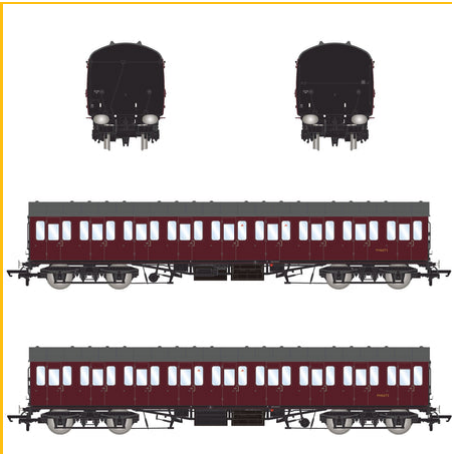

BR Mk1 57' Non-Gangway Coach - S - Lined Maroon (Low position) M46069

[Shop now](#)

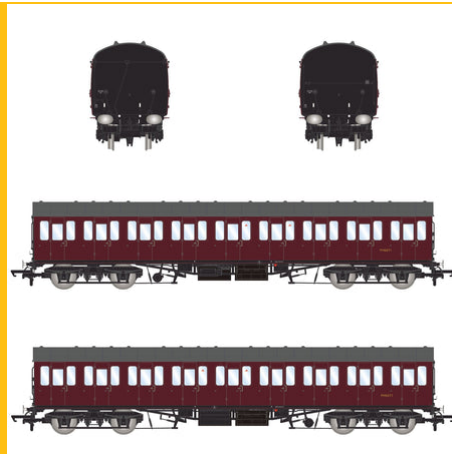

BR Mk1 57' Non-Gangway Coach - S - Lined Maroon (Low position) M46071

[Shop now](#)



BR Mk1 57' Non-Gangway Coach - SO - Plain Maroon M48038

[Shop now](#)



BR Mk1 57' Non-Gangway Coach - SO - Plain Maroon M48042

[Shop now](#)

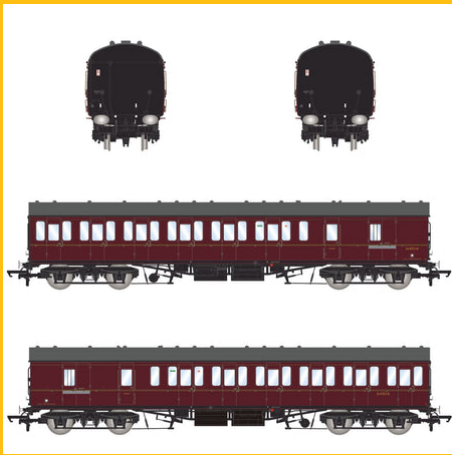

BR Mk1 57' Non-Gangway Coach - BS - Sc43216

[Shop now](#)

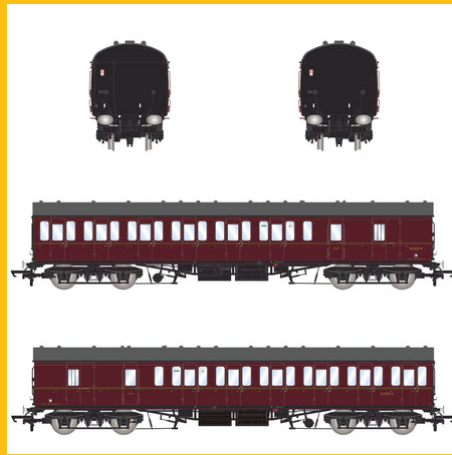

BR Mk1 57' Non-Gangway Coach - BS - Sc43314

[Shop now](#)

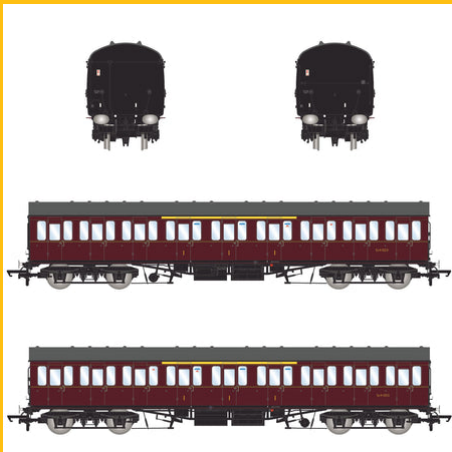

BR Mk1 57' Non-Gangway Coach - C - Sc41023

[Shop now](#)



BR Mk1 57' Non-Gangway Coach - S - Sc46175

[Shop now](#)

**Accurascale**  
60 Windsor Avenue  
Dalton House  
London  
SW19 2RR  
United Kingdom

Unsubscribe

© 2024 Accurascale