

Da: Accurascale <support@accurascale.co.uk>
Inviato: lunedì 6 novembre 2023 12:01
A: news_in@modellismoferroviario.it
Oggetto: 21 Ton Mineral Wagons In Stock And Shifting Fast

accurascale

21 Ton Mineral Wagons In Stock And Shifting Fast!



accurascale

Stalwarts of the BR standard wagon fleet, the 21 ton mineral wagons (TOPS cods MDO and MDV) were unsung workers on the network from the 1950s all the way into the early '90s and once a familiar sight across the rail network.



accurascale

Following the very quick selling out of our first run of these wagons, never before offered in high quality, Ready-To-Run format, we are back with an all new run, with new running numbers and featuring the MDW variant for the first time.



accurascale

These wagons are now in stock direct with us, and currently landing with local stockists. Despite price rises from our competitors, we are able to keep these beautiful wagons at the same brilliant value as the first run, priced at just £74.95 per triple pack and 10% off when you order two packs or more direct!

Order below!

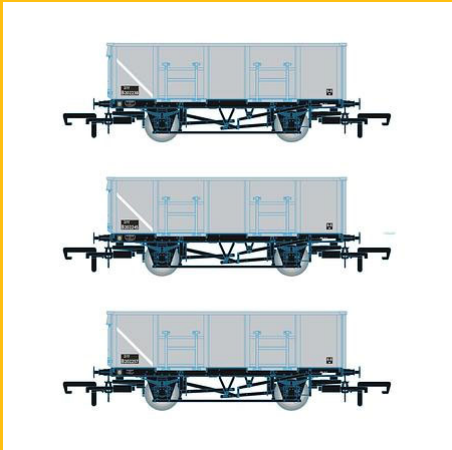

BR 21T MDO Mineral
Wagon BR Grey Pre-
TOPS - Pack F

[Shop now](#)



BR 21T MDO Mineral
Wagon BR Grey Pre-
TOPS - Pack G

[Shop now](#)



BR 21T MDO Mineral
Wagon BR Grey TOPS -
Pack H

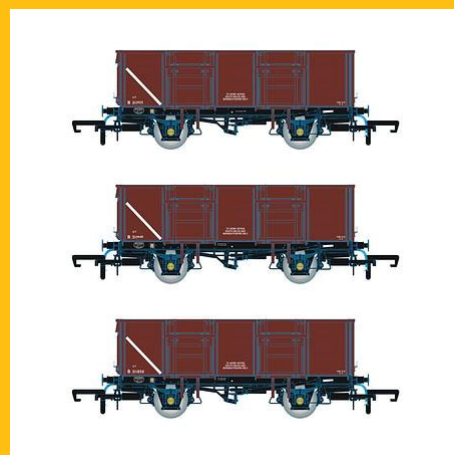

BR 21T MDV Mineral
Wagon Pre-TOPS
Bauxite - Pack F

Shop now



BR 21T MDV Mineral
Wagon TOPS Bauxite -
Pack G

Shop now



BR 21T MDW Mineral
Wagon TOPS Bauxite -
Pack A

Shop now

Shop now

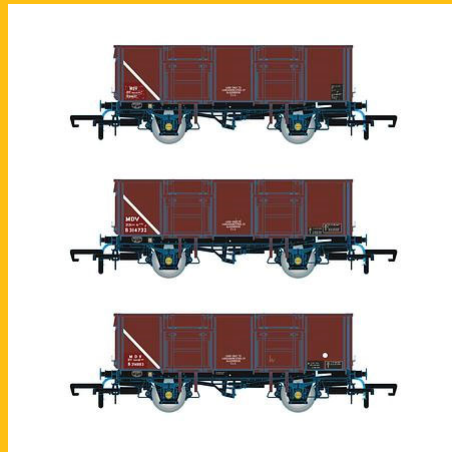

BR 21T MDV Mineral
Wagon TOPS Bauxite -
Pack H

Shop now

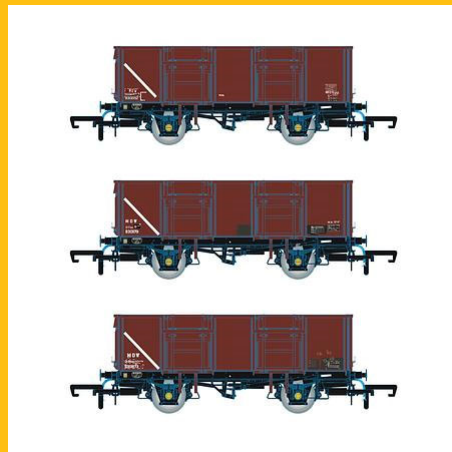

BR 21T MDW Mineral
Wagon TOPS Bauxite -
Pack B

Shop now

Accurascale
60 Windsor Avenue
Dalton House

London
SW19 2RR
United Kingdom

[Unsubscribe](#)

© 2023 Accurascale

Da: Accurascale <support@accurascale.co.uk>
Inviato: martedì 7 novembre 2023 13:38
A: news_in@modellismoferroviario.it
Oggetto: More Manors Now In Stock In Limited Numbers

accurascale

More Manors Now In Stock In Limited Numbers!



Great news! The rest of our 78xx Manor locomotives have arrived and pre-orders and retailer stock has been shipped.

We have a limited amount of these locomotives available for sale on our website, so make sure you grab them quickly before they go.

Dont forget your DCC decoders and driver packs too if you wish to upgrade your model, now all back in stock too!

Shop below!



7801 –
'Anthony
Manor' GWR
7800

Shop now



7808 –
'Cookham
Manor' GWR
7800

Shop now



7814 –
'Fringford
Manor ' BR
Manor Class

Shop now



7818 –
'Granville
Manor' GWR
7800

Shop now



7824 – 'Iford
Manor ' BR
Manor Class

Shop now



Accurathrash
GWR 'Manor'
Loksound DCC
Sound Decoder

Shop now

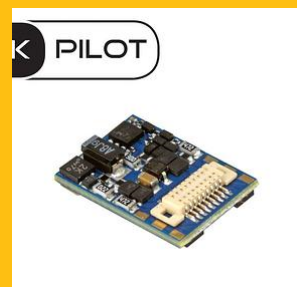
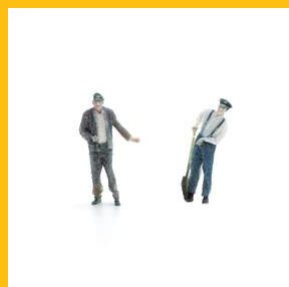

GWR 'Manor'
Crew -
Driver/Fireman
- BR

[Shop now](#)

GWR 'Manor'
Crew -
Driver/Fireman
- GWR

[Shop now](#)

GWR 'Manor'
Lokpilot DCC
Decoder

[Shop now](#)

Accurascale
60 Windsor Avenue
Dalton House
London
SW19 2RR
United Kingdom

[Unsubscribe](#)

© 2023 Accurascale

Da: Accurascale <support@accurascale.co.uk>
Inviato: mercoledì 8 novembre 2023 12:03
A: news_in@modellismoferroviario.it
Oggetto: BR Green and Blue 37s Shipping - Last Call For DRS 37/6s

accurascale

BR Green and Blue 37s Shipping - Last Call For DRS 37/6s



Great news! Our final batch of Class 37s from run one, the BR green originals and BR Blue 37001, along with our D6700 limited edition for Locomotion Models, are shipping out to customers and retailers as we speak! We have several thousand orders to process, so we estimate that they will take just over a week to complete. Keep an eye on your inbox for tracking information from us if you bought direct and updates from your retailer if you bought from them.



accurascale

For those who missed out, keep an eye on our Retailers for spare stock or you can click the 'notify me if item becomes available' button on our website as additional stock will be added to our website once our pre-orders are cleared!

Register Your Class 37 Interest



Meanwhile, we are down to the very last stocks of our lovely Class 37/6 variants. So, if BR green and early TOPS blue is a bit early for your tastes, or you just fancy seeing what all the fuss is about, check out our small remaining Class 37 stocks below, and recreate awesome scenes like Colwick Park above!



37602

[Shop now](#)



37605

[Shop now](#)



37606

[Shop now](#)



37607

[Shop now](#)

Accurascale

60 Windsor Avenue
Dalton House
London
SW19 2RR
United Kingdom

[Unsubscribe](#)

© 2023 Accurascale

Da: Accurascale <support@accurascale.co.uk>
Inviato: venerdì 10 novembre 2023 12:03
A: news_in@modellismoferroviario.it
Oggetto: Going, Going, Gone - Accurascale Locomotives About To Sell Out

accurascale

Going, Going, Gone - Accurascale Locomotives About To Sell Out!



Pondering your next locomotive purchase? Have your eye on a particular livery or locomotive and debating if you should take the plunge?

Well, it might be time to make that final call, as some of our locos are very close to selling out completely.

Our Class 37, 92 and 78xx Manors were voted 1st, 2nd and 3rd in the 2023 Hornby Magazine awards. If you're keen to see what the fuss is, or you would like to add another one of these locos to your

existing fleet, then perhaps it's time to pick one up, as once they're gone, they're gone.

Order below!



37602

[Shop now](#)



37606

[Shop now](#)



7801 – 'Anthony Manor'
GWR 7800

[Shop now](#)



7814 – 'Fringford Manor'
BR Manor Class

[Shop now](#)



92009 - 'Marco Polo'

[Shop now](#)



92038

[Shop now](#)

Accurascale
60 Windsor Avenue
Dalton House
London
SW19 2RR
United Kingdom

[Unsubscribe](#)

© 2023 Accurascale

Da: Accurascale <support@accurascale.co.uk>
Inviato: martedì 14 novembre 2023 12:03
A: news_in@modellismoferroviario.it
Oggetto: Last Of Our Manors Now In Stock

accurascale

Last Of Our Manors Now In Stock!



accurascale

Great news! The last two remaining 78xx Manors from our first run, 7810 Draycott Manor and 7819 Hinton Manor are now in stock and available to purchase on our website!

Looking splendid in BR lined green and GWR livery respectively, both locomotives are available in straight up DC/DCC ready and DCC sound fitted in limited numbers.



accurascale

In further good news, we have very, very limited amounts of other Manor locomotives previously sold out back in stock. So, if you previously missed out, here is your last chance to grab one before they sell out completely!

Price at just £169.99 DC/DCC ready and £259.99 DCC sound fitted for a large tender locomotive of mostly diecast construction and featuring a wealth of detail, our Manors represent once again unbeatable value for money.

Order below, and do not forget your drivers and decoders should you need some!



7810 – 'Draycott Manor'
BR Manor Class

Shop now



7819 – 'Hinton Manor'
GWR 7800

Shop now



7818 – 'Granville Manor'
GWR 7800

Shop now



7820 – 'Dinmore Manor'
BR Manor Class

Shop now



7808 – 'Cookham Manor'
GWR 7800

Shop now



7801 – 'Anthony Manor'
GWR 7800

Shop now





7814 – 'Fringford Manor '
BR Manor Class

[Shop now](#)



7824 – 'Iford Manor ' BR
Manor Class

[Shop now](#)



GWR 'Manor' Crew -
Driver/Fireman - GWR

[Shop now](#)



GWR 'Manor' Crew -
Driver/Fireman - BR

[Shop now](#)



GWR 'Manor' Lokpilot
DCC Decoder

[Shop now](#)



Accurathrash GWR
'Manor' Loksound DCC
Sound Decoder

[Shop now](#)

Accurascale
60 Windsor Avenue
Dalton House
London
SW19 2RR
United Kingdom

[Unsubscribe](#)

© 2023 Accurascale

Da: Accurascale <support@accurascale.co.uk>
Inviato: mercoledì 15 novembre 2023 12:03
A: news_in@modellismoferroviario.it
Oggetto: Accurascale Exclusive ZDV Back In Stock In Limited Numbers

accurascale

Accurascale Exclusive ZDV Back In Stock In Limited Numbers



accurascale

Great news! Now that our pre-orders of our new batch of MDO/MDV and MDW wagons are clear, we can put the remaining stocks of our Accurascale Exclusive wagon, our ZDV no LDB311717 back on sale on the website!

Used by the Electrification Engineers for collecting scrap metal during the latter stages of the Birmingham Cross City Electrification

scheme between Lichfield and Redditch between May 1991 and June 1993, it was a real survivor, becoming allocated to contractor Fastline at Doncaster and hung on well into the 2000s.

Priced at just £24.95 and coming in special presentation packaging, this limited edition model is only available via our website. Order below!



BR 21T ZDV Engineers Wagon TOPS Bauxite -
LDB311717 - Exclusive

[Shop now](#)

Fancy A Rake Of 21 Tonners?



BR 21T MDO Mineral
Wagon BR Grey Pre-
TOPS - Pack F

[Shop now](#)



BR 21T MDO Mineral
Wagon BR Grey Pre-
TOPS - Pack G

[Shop now](#)



BR 21T MDO Mineral
Wagon BR Grey TOPS -
Pack H

[Shop now](#)



BR 21T MDV Mineral
Wagon Pre-TOPS
Bauxite - Pack F

[Shop now](#)



BR 21T MDV Mineral
Wagon TOPS Bauxite -
Pack G

[Shop now](#)



BR 21T MDV Mineral
Wagon TOPS Bauxite -
Pack H

[Shop now](#)



BR 21T MDW Mineral
Wagon TOPS Bauxite -
Pack A

[Shop now](#)



BR 21T MDW Mineral
Wagon TOPS Bauxite -
Pack B

[Shop now](#)

Accurascale
60 Windsor Avenue
Dalton House
London
SW19 2RR
United Kingdom

Unsubscribe

© 2023 Accurascale

Da: Accurascale <support@accurascale.co.uk>
Inviato: giovedì 16 novembre 2023 13:03
A: news_in@modellismoferroviario.it
Oggetto: New Announcement - ECC CDAs In OO Gauge

accurascale

New Announcement - ECC CDAs In OO Gauge



accurascale

Great news! Do to a deluge of requests from modellers, and to mark the recent withdrawal from service of the real wagons, we are delighted to announce an all new run of our beautiful CDA hopper wagons in the iconic English China Clay (ECC) livery as they first appeared in service in early 1988.

Can it get any more classic Cornwall than these? Join us as we

look at the history of these icons of railfreight as well as our stunning models below!

History of the ECC CDAs

Our Model



accurascale

As you can see in the photos above, our CDA wagons feature a wealth of detail and crispness which signifies 'The Accurascale Way'. A diecast chassis, brass bearings and 26mm pinpoint axles means smooth running and excellent performance on your layout.

Particular attention has been paid to the detail differences over the traditional HAA wagons these were based on, such as the equipment at the wagon end, holes in the bodyside on one side, the underframe and of course, the hood/canopy.

Given the flexibility of our tooling we can also cater for those wagons as built as CDAs from new, as well as those converted from HAA hoppers, giving the modellers a true variety in their wagon rake.

Price And Availability



accurascale

Tempted? At a price of just £79.95 for 3 wagons, and 10% off when you order two packs or more, why wouldn't you be? Remember, you can pre-order direct for no money down, or spread the cost between now delivery via our monthly payment plans via [partial.ly](https://www.partial.ly) for no extra cost!

As you can see, the decoration samples are complete and have been signed off, allowing for production to get underway.

Pre-order yours via your local stockist, or direct below for a Q3 2024 delivery.



CDA China Clay - ECC
Blue - Pack A

[Shop now](#)



CDA China Clay - ECC
Blue - Pack B

[Shop now](#)



CDA China Clay - ECC
Blue - Pack C

[Shop now](#)



CDA China Clay - ECC
Blue - Pack D

[Shop now](#)



CDA China Clay - ECC
Blue - Pack E

[Shop now](#)



CDA China Clay - ECC
Blue Debranded - Pack
G

[Shop now](#)

CDA China Clay - ECC
Blue Debranded - Pack F

[Shop now](#)



CDA China Clay - ECC
Blue Debranded - Pack
H

[Shop now](#)

Accurascale
60 Windsor Avenue
Dalton House
London
SW19 2RR
United Kingdom

[Unsubscribe](#)

© 2023 Accurascale

Da: Accurascale <support@accurascale.co.uk>
Inviato: venerdì 17 novembre 2023 12:03
A: news_in@modellismoferroviario.it
Oggetto: Excited By Our ECC CDA Wagons? Maybe Consider Our New Class 50 To Haul Them

accurascale

**Excited By Our ECC CDA Wagons? Maybe
Consider Our New Class 50 To Haul Them**



The launch of Our ECC CDA wagons went down a storm yesterday, with almost 10% of the envisaged run already pre-ordered showing a huge demand for these China Clay icons.

As you know, we love to offer complete trains here at Accurascale, so we can certainly see a Cornish Class 37 in our future, and indeed our Class 50s are also perfect for these wagons, with 50149 in particular being famously paired with the then new hoppers in its sensational Railfreight triple grey livery in the late 1980s.

We have an exciting Class 50 update coming up within the next week, so keep an eye out for it.

50149 is an Accurascale Exclusive model, and available only direct via our website. Our allocation on this model and some of the other classmates are filling fast, so we recommend getting your pre-order in soon to avoid disappointment. It is no money down, after all!

Pre-order your 1980s Class 50 to match your CDAs below!

DCC Sound Fitted

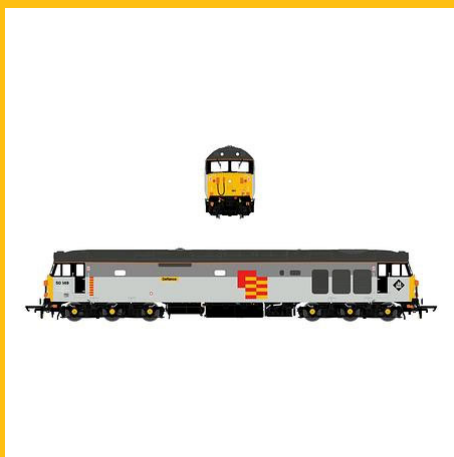

BR Class 50 - Railfreight
General - 50149
'Defiance' - Exclusive -
DCC Sound Fitted

[Shop now](#)



BR Class 50 - GWR
Green - 50007 'Sir
Edward Elgar' -
Exclusive - DCC Sound
Fitted

[Shop now](#)

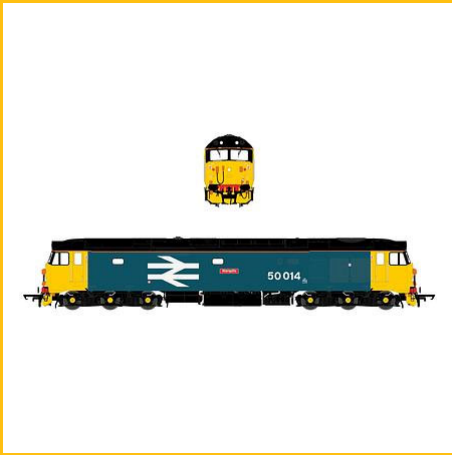

BR Class 50 - Large
Logo w/black roof -
50014 'Warspite' - DCC
Sound Fitted

[Shop now](#)

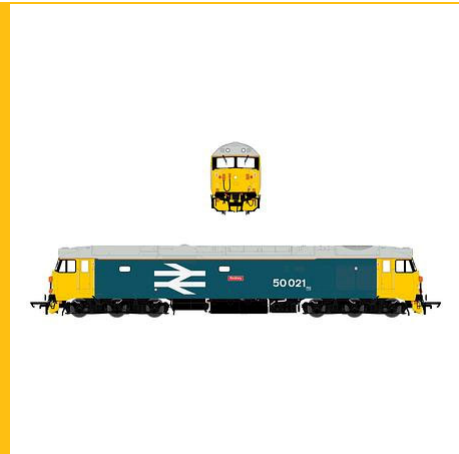

BR Class 50 - Large
Logo w/grey roof &
orange cantrail stripe -
50021 'Rodney' - DCC
Sound Fitted

[Shop now](#)



BR Class 50 - Original
NSE - 50017 'Royal Oak'
- DCC Sound Fitted

[Shop now](#)

DC/DCC Ready

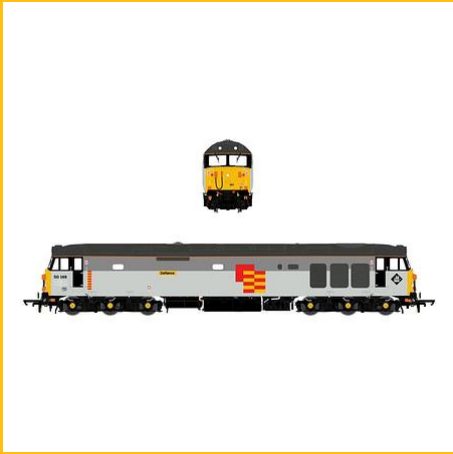

BR Class 50 - Railfreight
General - 50149
'Defiance' - Exclusive

[Shop now](#)



BR Class 50 - GWR
Green - 50007 'Sir
Edward Elgar' -
Exclusive

[Shop now](#)

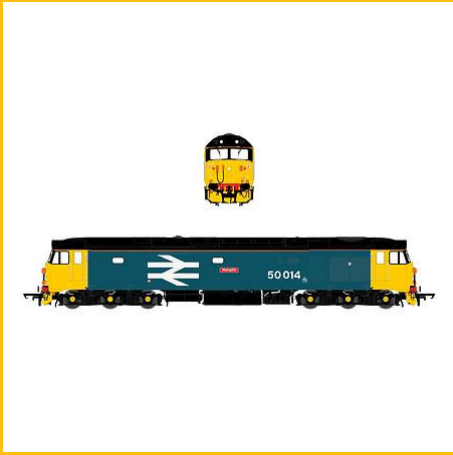

BR Class 50 - Large
Logo w/black roof -
50014 'Warspite'

[Shop now](#)

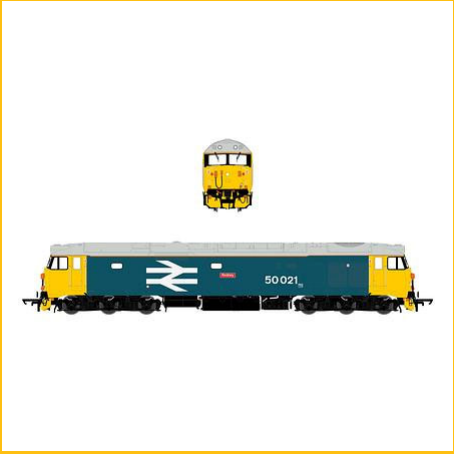

BR Class 50 - Large
Logo w/grey roof &
orange cantrail stripe -
50021 'Rodney'

[Shop now](#)



BR Class 50 - Original
NSE - 50017 'Royal Oak'

[Shop now](#)

Don't Forget Those CDAs



CDA China Clay - ECC
Blue - Pack A

[Shop now](#)



CDA China Clay - ECC
Blue - Pack B

[Shop now](#)



CDA China Clay - ECC
Blue - Pack C

[Shop now](#)



CDA China Clay - ECC
Blue - Pack D

[Shop now](#)



CDA China Clay - ECC
Blue - Pack E

[Shop now](#)



CDA China Clay - ECC
Blue Debranded - Pack F

[Shop now](#)



CDA China Clay - ECC
Blue Debranded - Pack
G

[Shop now](#)

CDA China Clay - ECC
Blue Debranded - Pack
H

[Shop now](#)

Mark 2c Coaches; Also Perfect For Your 50



Mark 2c BFK 17132

[Shop now](#)



Mark 2c TSO(T) 6500

[Shop now](#)



Mark 2c BSO 9446

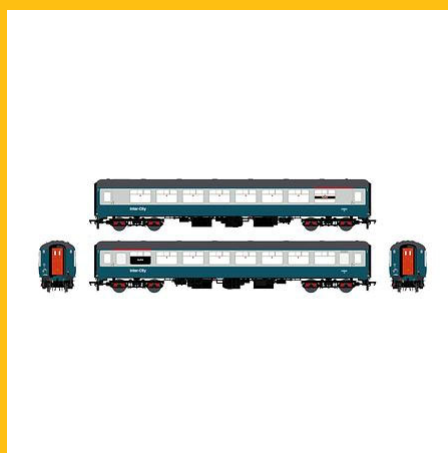

Mark 2c TSO(T) E6522

[Shop now](#)

[Shop now](#)

Accurascale
60 Windsor Avenue
Dalton House
London
SW19 2RR
United Kingdom

[Unsubscribe](#)

© 2023 Accurascale

Da: mthelectrictrains.activehosted.com@mail-42-236.acems1.com per conto di MTH Electric Trains
<sales@mth-railking.com>
Inviato: venerdì 17 novembre 2023 13:02
A: giuliano
Oggetto: MTH Electric Trains Special Announcement - November 17, 2023

[Click here to see a web copy of this email](#)

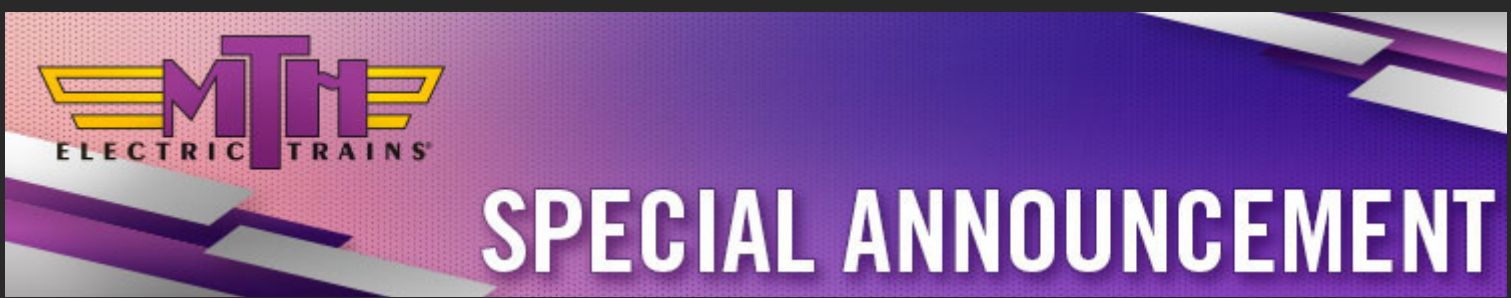

[MTH Home](#)

[My MTH](#)

[Product Locator](#)

[MTH News](#)

[MTH Service](#)

[Contact Us](#)

Uncataloged RailKing O Gauge Southern 4-Bay Cylindrical Hopper Cars Announced



November 17, 2023 - M.T.H. Electric Trains has announced an exclusive RailKing O Gauge 4-Bay Cylindrical Hopper Car in a distinctive Southern "map" livery scheme for exclusive distribution for M.T.H. Authorized Retailer [The Train Loft](#). The cars will be produced in two car numbers in extremely limited quantities. They will be available for delivery beginning in February 2024.

[30-75741](#) Southern 4-Bay Cylindrical Hopper Car
Car No. 1960



M.T.H. Electric Trains will be releasing the 2024 O Gauge RailKing 50' Double Door Plugged Box Car in five different liveries next Spring. Each of these offerings will be available in limited quantities and is expected to begin shipping to M.T.H. Authorized Retailers in April 2024.

Check out each of these offerings [HERE](#).

These items are available to order from your local [M.T.H. Authorized Retailer](#).

Pre-Order Price: \$69.95

Download The Order Form: [HERE](#) to purchase from Train Loft.

[30-75742](#) Southern 4-Bay Cylindrical Hopper Car

Car No. 1970

Pre-Order Price: \$69.95

Download The Order Form: [HERE](#) to purchase from Train Loft.

ABOUT THE O GAUGE 4-BAY CYLINDRICAL HOPPER CAR

Until the advent of the covered hopper, bulk commodities like grain and cement were packed in sacks and loaded into boxcars. Loading and unloading was a tedious, time-consuming affair. In the 1930s, a few railroads took the basic coal hopper design and added a roof with loading hatches, enabling bulk commodities to be loaded from the top and unloaded from the bottom. In 1953, Pullman-Standard's 70-ton PS-2 became the first mass-produced covered hopper to be widely owned by U.S. railroads.

But these pioneering covered hoppers had one problem: Like other cars of their time, they were built on a frame with a center sill, or support beam, that ran down the middle. Some of the load would cake or collect on the beam, making it difficult to fully unload the cars. In 1961, American Car and Foundry solved the problem with the first center-flow covered hopper, with its support beams on the outside of the frame and unobstructed, full-width unloading doors. Today's cylindrical hoppers are all descended from that ACF innovation. Our model represents a modern 100-ton, 4-bay car designed for lighter-density loads like grains and plastic pellets; denser commodities are generally shipped in 2- or 3-bay cars.

EXCLUSIVELY AVAILABLE THRU

[The Train Loft](#)

4007-B Country Club Road

Winston-Salem, North Carolina 27104

336-760-9817

www.trainloft.com

JKonc52032@aol.com



M.T.H. Electric Trains will be releasing the 2024 O Scale Premier Gondola Car w/LCL Containers in five different liveries next Spring. Each of these offerings will be available in two car numbers in limited quantities and is expected to begin shipping to M.T.H. Authorized Retailers in June 2024.

Check out each of these offerings [HERE](#).

These items are available to order from your local [M.T.H. Authorized Retailer](#).



Follow Us On



© 2023 M.T.H. Electric Trains
6660 Santa Barbara Road - Suite 20, Elkridge, MD 21075 (410)381-2580

Sent to: news_in@modellismoferroviario.it

[Unsubscribe](#)

MTH Electric Trains, 6660 Santa Barbara Road Suite 20, Elkridge, MD 21046, USA

Da: Accurascale <support@accurascale.co.uk>
Inviato: martedì 21 novembre 2023 12:02
A: news_in@modellismoferroviario.it
Oggetto: Original BR Green and Rail Blue Class 37s Back In Stock On Our Website And Selling Fast

accurascale

Original Class 37s Back In Stock On Our Website And Selling Fast



Great news! The last batch of our first production run of award winning Class 37s, representing the original 5 locomotives and consisting of D6702 in BR Green with small yellow panel, D6704 in BR Green with full yellow panel and 37001 in BR Blue are now in stock and back on sale on our website in limited numbers.

Don't miss out! D6703 is already fully sold out as are some sound variants. We will soon have our Accurathrash DCC sound speakers

back in stock too should you wish to upgrade your model to full fat sound with our original sound decoders.

Shop below!



37001

Shop now



D6702

Shop now



D6704

Shop now

Don't Forget Our Class 37 Accessories



Accurathrash
Class 37
Loksound
'Original' DCC
Sound Decoder

Shop now



Accurathrash
Class 37
Speaker
Retaining Clips
(Pack of 2)

Shop now



Class 37 Crew -
Driver/Secondman
- BR

Shop now



Class 37 - EM /
18.2mm Gauge
Drop-In Wheel
Sets

[Shop now](#)



Class 37 - P4 /
18.83 mm
Gauge Drop-In
Wheel Sets

[Shop now](#)



Class 37 Crew -
Driver/Driver -
Privatisation

[Shop now](#)

Looking For A More Modern Class 37? Check Out Our DRS Class 37/6 Locos



37602

[Shop now](#)



37605

[Shop now](#)



37607

[Shop now](#)

Accurascale
60 Windsor Avenue
Dalton House
London
SW19 2RR
United Kingdom

Unsubscribe

© 2023 Accurascale

Da: Accurascale <support@accurascale.co.uk>
Inviato: giovedì 23 novembre 2023 12:12
A: news_in@modellismoferroviario.it
Oggetto: New Announcement - The 57xx Pannier Tank Family in 00/4mm

accurascale

Holy Duck - It's An AccuraPannier!



accurascale

Following the recent success and reaction to our GWR 78xx Manor Class locomotives, and the feedback following the launch of our GER Buckjumpers, we thought we would combine the love for GWR prototypes with our new found knowledge of tank engines.

This delicious recipe will bring you the ultimate model of one of the most iconic tank locomotives of them all, the GWR 57xx, 67xx and 8750 Class Pannier Tanks!

Why Pannier Tanks?



accurascale

Before anyone says the 'D' word (and we don't mean Duck!), we need to explain where our Pannier Tanks differ to what has gone before.

Like our class 37 project, amongst others, we have done our Panniers in "The Accurascale Way", with lots of variations and detail differences. We have started by 'filling the gaps' and cover variants never before offered in ready-to-run format. This means locomotives with backplate feed (not top feed fitted) feature heavily in our launch range. Another striking variation amongst the contractor built locomotives was the use of rivets for constructing the tanks. Later modifications like the large "8750" cab is also included as is the 67xx sub class that were built without steam heat or vacuum brakes – with relevant pipes and equipment missing from the model as per prototype.

Learn all about the different detail differences on our model, and see the full specification in our launch blog and video by clicking the button below!

Price And Availability



As you can see from our lovely pics, the locomotive is now fully tooled, with first samples being on display on our stand at the 2023 Warley MRC Exhibition at the NEC in Birmingham this weekend. These samples are currently undergoing testing and evaluation by our technical team before they progress to the decoration and production stages.

It's anticipated that the locomotives will arrive in stock in Q1, 2025. Our Pannier Tanks are priced at £139.95 for DC/DCC Ready models, and £239.95 for DCC Sound Fitted models. Locomotives can be pre-ordered via our website for no money down or via monthly instalments at no extra cost, or via our network of local stockists.

A further announcement of an "Accurascale Exclusive" model, available exclusively via the Accurascale website only, will take place in the coming months.

Pre-Order DCC Sound Fitted Locomotives



5700 Class -
7755 -
Shirtbutton
Green - DCC
Sound Fitted

[Shop now](#)



5700 Class -
5754 - Great
Western Green
- DCC Sound
Fitted

[Shop now](#)



5700 Class -
7714 - Early
Emblem Black -
DCC Sound
Fitted

[Shop now](#)



5700 Class -
5741 - GWR
Green - DCC
Sound Fitted

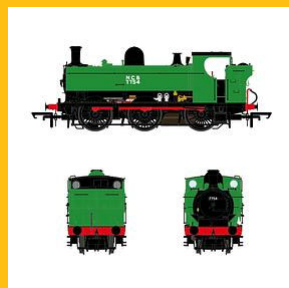

5700 Class -
7754 - NCB
Green - DCC
Sound Fitted



6700 Class -
6743 - Great
Western Green
- DCC Sound
Fitted

Shop now



8750 Class -
8763 - Early
Emblem Lined
Black - DCC
Sound Fitted

Shop now

Shop now



8750 Class -
9681 - Late
Crest Black -
DCC Sound
Fitted

Shop now

Shop now



8750 Class -
9741 - British
Railways Green
- DCC Sound
Fitted

Shop now

Pre-Order DC/DCC Ready Locomotives



5700 Class -
5741 - GWR
Green

Shop now



5700 Class -
5754 - Great
Western Green

Shop now

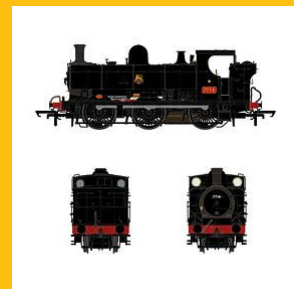

5700 Class -
7714 - Early
Emblem Black

Shop now



5700 Class -
7754 - NCB
Green

[Shop now](#)



5700 Class -
7755 -
Shirtbutton
Green

[Shop now](#)



6700 Class -
6743 - Great
Western Green

[Shop now](#)



8750 Class -
8763 - Early
Emblem Lined
Black

[Shop now](#)



8750 Class -
9681 - Late
Crest Black

[Shop now](#)



8750 Class -
9741 - British
Railways Green

[Shop now](#)

Learn More About Panniers



Intrigued by our Panniers and want to find out more about these attractive machines? Then join our Project Manager Steve Purves as he details the history of these beauties in our "History File" which you can read via the button below!

[Learn More About the 57xx Pannier Tank Family](#)

Accurascale
60 Windsor Avenue
Dalton House
London
SW19 2RR
United Kingdom

[Unsubscribe](#)

© 2023 Accurascale

Da: Accurascale <support@accurascale.co.uk>
Inviato: giovedì 23 novembre 2023 17:04
A: news_in@modellismoferroviario.it
Oggetto: Class 50 Update - First Decorated Samples Arrive

accurascale

Class 50 Update - First Decorated Samples Arrive



accurascale

It's been all go here at Accurascale Towers, with the final batch of Class 37s, 21 ton mineral wagons and Manors arriving into stock, the first batch of Class 31s in production along with other goodies too and of course, Warley this weekend!

But what about our Warley announcement from last year, the Class 50? Well, it's long overdue an update, and we are delighted to announce that the first of our decorated samples have arrived ahead of the show this weekend, and how fine they look too!



accurascale

Our first two decorated samples to land especially for the Warley show are 50014 "Warspite" in BR Large Logo livery with black roof, and 50008 "Thunderer" in her current and rather attractive Hanson and Hall grey scheme.



accurascale

As ever, fit and finish of these early samples requires some improvement, but our Accurahoover is shaping up very well indeed and it is always wonderful to reach the decorated milestone to see how paint sits on a locomotive. It also helps to show the depth to detail and mouldings. That removable roof panel needs to sit lower though, and will be addressed on the final models that will land on your layouts! The copper coloured pick ups behind the bogie frames will also be darkened on the final models, and the body will sit right on the chassis!



Our Class 50 will follow in the footsteps of our Class 31 and feature a fully operational roof fan powered by a separate motor. It also looks the part, which always helps!



We will have these pair of beauties on our stand at Warley for a closer look this coming weekend, and the other decorated samples for run one are will be with us in the next couple of weeks for assessment and we will bring you plenty of snaps of them too.

Of course, we are 12 months on from our initial Class 50 announcement and had hoped to be further advanced with deliveries landing about now, but the ongoing semi-conductor shortage coupled with factory backlogs in completing production of other locomotives has slowed our pace somewhat. This has impacted the Class 50s but we are now at a stage where production can commence and will do shortly, once these samples are signed off, with a slot at the factory booked. This means that the revised delivery date for the Class 50 is now Q3 2024. We apologise for this delay but it has been beyond our control.



accurascale

With the Class 50 production slot now booked and quantities finalised there is only limited stock available left for sale as we cannot now increase the size of the production run. So, if you fancy one, make sure you place your pre-order with your local stockist, or direct via our website very soon before they sell out. Don't forget about our couple of very tasty Accurascale Exclusives too, along with limited editions for Rails of Sheffield and The Fifty Fund.

DCC Sound Fitted



BR Class 50 - BR Blue -
D423 - DCC Sound
Fitted

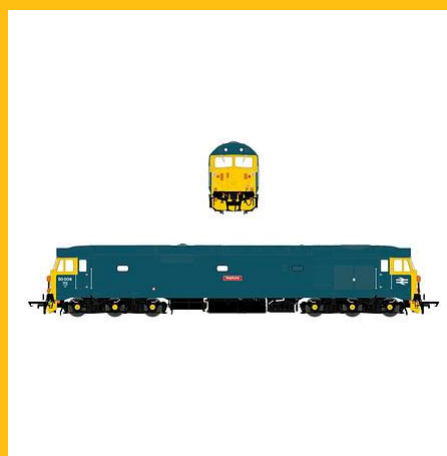

BR Class 50 - BR Blue -
50006 'Neptune' - DCC
Sound Fitted

Shop now



BR Class 50 - GWR
Green - 50007 'Sir
Edward Elgar' -
Exclusive - DCC Sound
Fitted

Shop now

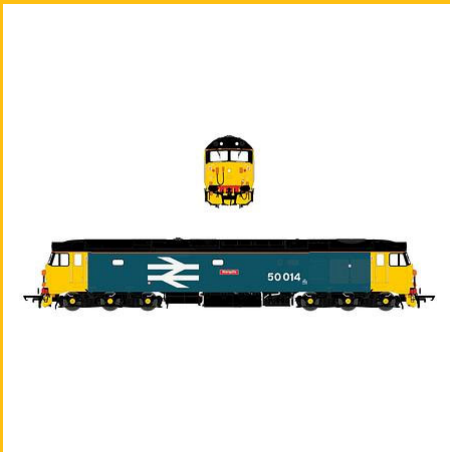

BR Class 50 - Large
Logo w/black roof -
50014 'Warspite' - DCC
Sound Fitted

Shop now

Shop now

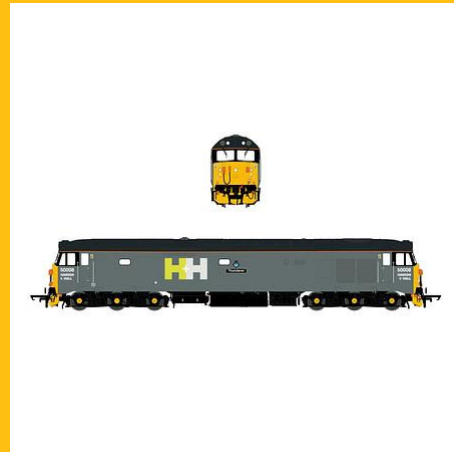

BR Class 50 -
Hanson+Hall/Rail
Adventure - 50008
'Thunderer' - DCC Sound
Fitted

Shop now

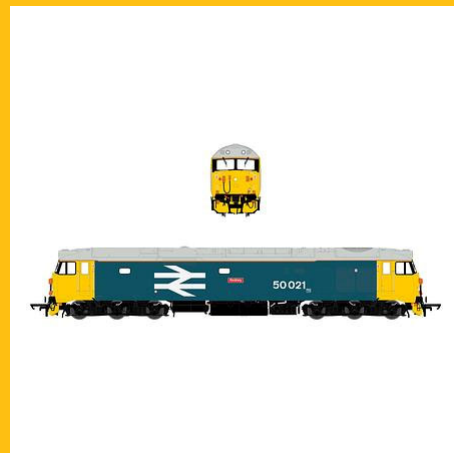

BR Class 50 - Large
Logo w/grey roof &
orange cantrail stripe -
50021 'Rodney' - DCC
Sound Fitted

Shop now



BR Class 50 - Original
NSE - 50017 'Royal Oak'
- DCC Sound Fitted

[Shop now](#)

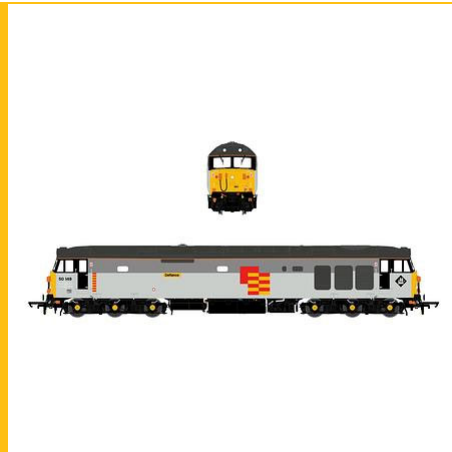

BR Class 50 - Railfreight
General - 50149
'Defiance' - Exclusive -
DCC Sound Fitted

[Shop now](#)

DC/DCC Ready Locomotives



BR Class 50 - BR Blue -
D423

[Shop now](#)

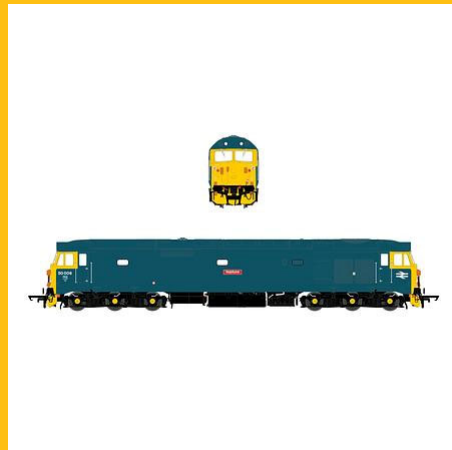

BR Class 50 - BR Blue -
50006 'Neptune'

[Shop now](#)



BR Class 50 - GWR
Green - 50007 'Sir
Edward Elgar' -
Exclusive

[Shop now](#)

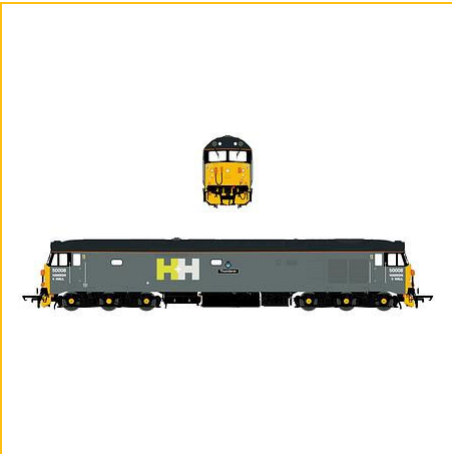

BR Class 50 -
Hanson+Hall/Rail
Adventure - 50008
'Thunderer'

[Shop now](#)

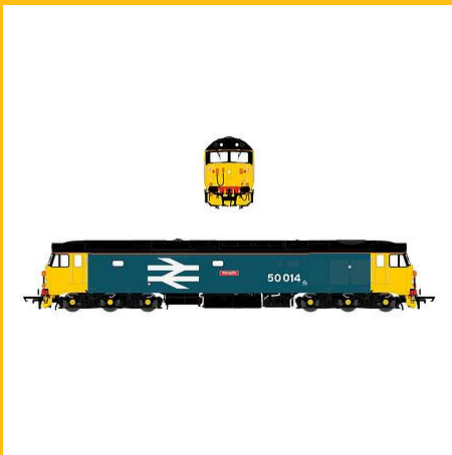

BR Class 50 - Large
Logo w/black roof -
50014 'Warspite'

[Shop now](#)

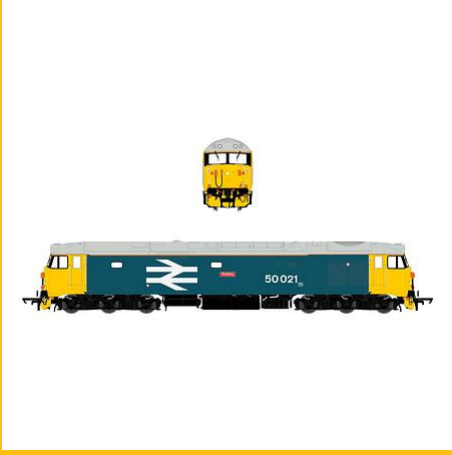

BR Class 50 - Large
Logo w/grey roof &
orange cantrail stripe -
50021 'Rodney'

[Shop now](#)



BR Class 50 - Original
NSE - 50017 'Royal Oak'

[Shop now](#)

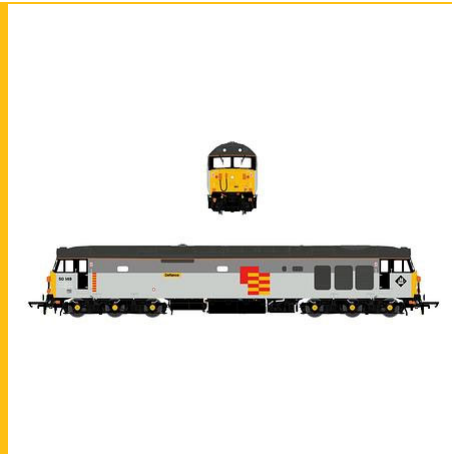

BR Class 50 - Railfreight
General - 50149
'Defiance' - Exclusive

[Shop now](#)

Accurascale
60 Windsor Avenue
Dalton House
London
SW19 2RR
United Kingdom

[Unsubscribe](#)

© 2023 Accurascale

Da: RAILNSCALE <donotreply@wordpress.com>
Inviato: giovedì 23 novembre 2023 19:03
A: news_in@modellismoferroviario.it
Oggetto: [New post] Collectibles: Mercedes-Benz 200 Strich-8



RAILNSCALE

Collectibles: Mercedes-Benz 200 Strich-8



RAILNSCALE

Nov 23





N5393C - Mercedes-Benz 200 - Light blue (N 1:160) ► [SHOP](#)

N5393M - Mercedes-Benz 200 - Maroon (N 1:160) ► [SHOP](#)

COLLECTIBLES

Mercedes-Benz 200 (W115) (Era IV)

In 1968, Mercedes-Benz introduced the 200-280 series (W115), also known as the 'Strich-8' (slash 8). This scale N car model is an exact replica of the original and has many special details. Characteristic of this car is its sleek lines and great solidity. The diesel models in particular can handle very high mileage and were therefore popular as taxis.

RAILNSCALE Collectibles are hand painted and highly detailed finished models.

Mercedes-Benz 200 Strich-8 (Epoche IV)

Im Jahr 1968 stellte Mercedes-Benz die Baureihe 200-280 (W115) vor, auch bekannt als „Strich-8“. Dieses Automodell im Spur N ist eine exakte Nachbildung des Originals und verfügt über viele besondere Details. Charakteristisch für dieses Auto sind seine schlanken Linien und seine große Solidität. Vor allem die Dieselmotoren bewältigen eine sehr hohe Laufleistung und waren daher als Taxi beliebt.

Bei den RAILNSCALE Collectibles handelt es sich um handbemalte und hochdetaillierte Fertigmodelle.



RS292C - Mercedes-Benz 200 (W115) - Light blue
Hand painted finished model

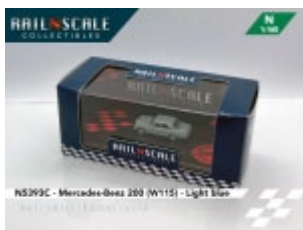

RS292C - Mercedes-Benz 200 (W115) - Light blue



RS292C - Mercedes-Benz 200 (W115) - Light blue
Hand painted finished model

■ Mercedes-Benz 200 (W115) (Epoque IV)

En 1968, Mercedes-Benz a présenté la série 200-280 (W115), également connue sous le nom de « Strich-8 » (barre 8). Ce modèle de voiture à l'échelle N est une réplique exacte de l'original et présente de nombreux détails spéciaux. La caractéristique de cette voiture réside dans ses lignes épurées et sa grande solidité. Les modèles diesel en particulier peuvent supporter des kilomètres très élevés et étaient donc populaires comme taxis.

Les RAILSCALE Collectibles sont des modèles finis peints à la main et très détaillés.



RS293M - Mercedes-Benz 200 (W115) - Maroon
Hand painted finished model



RS293M - Mercedes-Benz 200 (W115) - Maroon



Mercedes-Benz 200 (W115) (Tijdperk IV)

In 1968 introduceerde Mercedes-Benz de 200-280 serie (W115), die ook wel bekend staat als de 'Strich-8' (streep 8). Dit N-schaal automodel is een exacte replica van het origineel en heeft vele bijzondere details. Kenmerkend aan deze auto is zijn strakke lijnvoering en grote degelijkheid. Met name de dieselmotoren kunnen zeer hoge kilometerstanden aan en waren mede daarom populair als taxi. RAILNSCALE Collectibles zijn met de hand beschilderde en zeer gedetailleerd afgewerkte modellen.



14+ Not suitable for children under the age of 14.
Nicht geeignet für Kinder unter 14 Jahren.
Ne convient pas aux enfants de moins de 14 ans.
Niet geschikt voor kinderen onder 14 jaar.

[Manage](#) your email settings or unsubscribe.

Trouble clicking? Copy and paste this URL into your browser:

<http://railnscale.com/2023/11/23/collectibles-mercedes-benz-200-strich-8/>



Get the Jetpack app to use Reader anywhere, anytime

Follow your favorite sites, save posts to read later, and get real-time notifications for likes and comments.



 **WordPress.com**

Automattic, Inc. - 60 29th St. #343, San Francisco, CA 94110

Da: Accurascale <support@accurascale.co.uk>
Inviato: venerdì 24 novembre 2023 13:05
A: news_in@modellismoferroviario.it
Oggetto: Class 89 Update November 2023

accurascale

Class 89 Update November 2023



We've been busy delivering a lot of new models in recent weeks and months, but what about the next projects?

Well, one of those is the Class 89, our rather wonderful one-off prototype electric model that we are producing in association with Rails of Sheffield.



Back in the summer we showed off the first decorated samples of our Badger, and they certainly got the modelling public salivating at the prospect of one gracing their layout or collection in the near future.

We did at the time outline one particular difficult area that we needed to nail in order to sign off on this model and that was the DCC sound file. The real locomotive is unique as we know, but this extends to its innards, and the 89 as a result sounds like nothing else on the rails.



We had hoped that the real locomotive would be back together and that we could record it in time, but this sadly has not been the case, despite the amazing skills and dedication to the people who are working on her.

As a result of this, we had hung on as long as we can, but now we must defer to historical recordings to replicate the sound for our model. This is easy enough done, but waiting for the real locomotive to be repaired resulted in us missing our production slot at the factory. We also had some work to do with the pantograph, which sits higher than the Class 92s so some fettling was also required which came up in the testing phase.



The good news is that these issues are no longer halting progress of our model, and it is now in production. However, this does mean there has been a further delay, with the finished models now due in stock in Q3, 2024. We sincerely apologise for this delay, but we really wanted the best sound file to match this unique locomotive to really take it to the next level. We're delighted that the sound file we are preparing will sound fantastic though, and will demonstrate it in the new year.



In the meantime production has commenced and we can no longer add any more capacity to the production lines, so remaining stock is limited. If you fancy an 89, now is the time to place your pre-order to avoid disappointment. Order via our friends at Rails of Sheffield, or below!



BR Class 89 -
89001 - GNER
(Gold Lettering)

Shop now



BR Class 89 -
89001 - GNER
(White
Lettering)

Shop now



BR Class 89 -
89001 -
InterCity
Executive

Shop now



BR Class 89 -
89001 -
InterCity
Swallow
(Original)

[Shop now](#)



BR Class 89 -
89001 -
InterCity
Swallow
(Present Day)

[Shop now](#)

Accurascale
60 Windsor Avenue
Dalton House
London
SW19 2RR
United Kingdom

[Unsubscribe](#)

© 2023 Accurascale

Da: Accurascale <support@accurascale.co.uk>
Inviato: sabato 25 novembre 2023 12:03
A: news_in@modellismoferroviario.it
Oggetto: Bargain of The Year? Our Class 92 This Weekend Only

accurascale

Bargain of The Year? Our Class 92 This Weekend Only!



What is the true meaning of value?

We believe that it is the most bang for your buck. So, how about this for amazing value?

Our Class 92, with TWIN DCC operated pantographs, stay alive capacitor pack, Accurathrash speaker in all models, comprehensive lighting packages, amazing smooth and powerful drive system and a wealth of separately applied parts for **JUST £152.00 DC/DCC Ready or £223.99 DCC Sound Fitted!**

Now, that's simply astonishing value. This weekend only until 6pm, Monday, November 27th while stocks last!

Order Below!



92009 - 'Marco Polo'

[Shop now](#)



92036 - 'Bertolt Brecht'

[Shop now](#)



92038

[Shop now](#)



92042

[Shop now](#)



92043 – 'Debussey'

[Shop now](#)



Class 92 - Stobart -
92017 'Bart the Engine'

[Shop now](#)

Accurascale
60 Windsor Avenue
Dalton House
London
SW19 2RR
United Kingdom

[Unsubscribe](#)

© 2023 Accurascale

Da: Accurascale <support@accurascale.co.uk>
Inviato: domenica 26 novembre 2023 12:04
A: news_in@modellismoferroviario.it
Oggetto: Amazing Wagon At Amazing Prices This Black Friday Sale Weekend

accurascale

Amazing Wagon At Amazing Prices This Black Friday Sale Weekend



Our annual Black Friday sale is back, this weekend until 6pm on Monday, November 27th at 6pm or while stocks last!

Get 20% off on selected wagon triple packs, while still getting an additional 10% off when you buy two packs or more, along with FREE UK postage and packaging and 3% CASH BACK on every purchase!

Amazing value on high quality, award winning wagons.

Shop below.



MHA - DB -
Pack 1

[Shop now](#)



MHA - DB -
Pack 2

[Shop now](#)



MHA - EWS -
Pack 1

[Shop now](#)



MHA - EWS -
Pack 2

[Shop now](#)



HBA - Loadhaul
- Pack 1

[Shop now](#)



HBA -
Railfreight Red
- Pack 1

[Shop now](#)



HCA - EWS -
Pack 1



HCA - Freight
Brown - Pack 1



HMA - Mainline
blue - Pack 1

Shop now



PFA - British Fuels Coal Containers I

Shop now

Shop now



PFA - DRS LLNW - 2031 Container Pack 4

Shop now

Shop now



PFA - DRS LLNW - 2031 Container Pack 5

Shop now



PFA - DRS LLNW - 2031 Container Pack 6

Shop now



VTG Castle Cement - T

Shop now



VTG Castle Cement - U

Shop now



Rawie Friction Bufferstop -



Rawie Friction Bufferstop -



Rawie Friction Bufferstop -

Coupler Pocket
- Twin Pack

Shop now



Chaldron
Wagon Harton
Colliery - Pack
O

Shop now

LED - Coupler
Pocket

Shop now



Chaldron
Wagon
Seaham
Harbour - Pack
M

Shop now

Standard - Twin
Pack

Shop now



Chaldron
Wagon
Throckley
Colliery - Pack
N

Shop now



Hetton Colliery
Chaldron Pack

Shop now



North Eastern
Railway
Chaldron -
Pack L

Shop now



Pontop and
Jarrow
Chaldron Pack

Shop now



Stella Coal
Company
Chaldron Pack

[Shop now](#)



Vane /
Londonderry
Chaldron Pack

[Shop now](#)



Wearmouth
Coal Co.
Chaldron Pack

[Shop now](#)

Accurascale
60 Windsor Avenue
Dalton House
London
SW19 2RR
United Kingdom

[Unsubscribe](#)

© 2023 Accurascale

Da: Accurascale <support@accurascale.co.uk>
Inviato: lunedì 27 novembre 2023 11:03
A: news_in@modellismoferroviario.it
Oggetto: Biggest O Gauge Bargain Around? Sale Ends Today 6pm

accurascale

Biggest O Gauge Bargain Around? Sale Ends Today 6pm



O gauge fans! How about some high quality wagons with HUGE savings?

Pick up our HUO/24.5 Ton hopper wagons that are **17% off**, with an **additional 20% off today until 6pm**, AND a further **10% off**

when you buy two or more, **FREE UK postage and packaging AND 3% cash back** off a future purchase.

How many savings? All of them!

This means that our HUO hoppers are **reduced to £39.92** each with the further 10% off when you buy 2 or more, reduced from an RRP of £59.99 each.

Incredible savings that you can avail of by ordering below!



BR 24.5T HOP24/HUO
Coal Hopper - I -
B334997

[Shop now](#)



BR 24.5T HOP24/HUO
Coal Hopper - J -
B335236

[Shop now](#)



BR 24.5T HOP24/HUO
Coal Hopper - K -
B337135N



BR 24.5T HOP24/HUO
Coal Hopper - L -
B333850

[Shop now](#)



BR 24.5T HOP24/HUO
Coal Hopper - M -
B334126N

[Shop now](#)

[Shop now](#)



BR 24.5T HOP24/HUO
Coal Hopper - N -
B333786

[Shop now](#)



BR 24.5T HOP24/HUO
Coal Hopper - O -
B333955

[Shop now](#)

Accurascale

60 Windsor Avenue
Dalton House
London
SW19 2RR
United Kingdom

[Unsubscribe](#)

© 2023 Accurascale

Da: Accurascale <support@accurascale.co.uk>
Inviato: martedì 28 novembre 2023 12:03
A: news_in@modellismoferroviario.it
Oggetto: Excited by our Panniers? Then Check Out Our Other Western Models

accurascale

Excited by our Panniers? Then Check Out Our Other Western Models



accurascale

There is quite the buzz around our latest locomotive announcement; the GWR/BR 57xx, 67xx and 8750 Pannier Tank family of locomotives. Indeed, since we announced them last Thursday, pre-orders have been as strong as when we first announced our Class 37 range and allocations are filling up fast!

Of course, the Panniers are not due for just over a year, but if you want to try some Accurascale awesomeness on your Western

themed layout, we do have some nice models in stock for you to sample first.



We have a limited supply of our rather lovely 78xx Manor locomotives in stock. Featuring mostly diecast construction, a wealth of detail and excellent smooth running and haulage capabilities, they are the true bargain of the OO gauge steam world, priced from just £159.99. You'd have to go a long way to find a mostly diecast steam loco for a similar price!

Our gorgeous Siphon G vans are also in stock in a variety of liveries to match your pannier tank (or manor!) retailing at just £54.95 each with 10% off when you buy two or more. Once again, the detail needs to be seen to be believed!

Remember, when you buy direct we do free UK postage and packaging, 10% off when you buy any two wagon packs or coaches (including Siphons!) and 3% cash back off you next order through loyalty points (perfect for the pannier pre-order!)

Browse and shop below!



7808 – 'Cookham Manor'
GWR 7800

Shop now



7810 – 'Draycott Manor'
BR Manor Class

Shop now



7814 – 'Fringford Manor'
BR Manor Class

Shop now



7818 – 'Granville Manor'
GWR 7800

Shop now



7819 – 'Hinton Manor'
GWR 7800

Shop now



7820 – 'Dinmore Manor'
BR Manor Class

Shop now

7824 – 'Iford Manor'
BR Manor Class

Shop now



Siphon G - Dia. O.33 -
GWR Brown: 2789

Shop now

Siphon G - Dia. O.33 -
GWR Brown: 2924

Shop now



Siphon G - Dia. O.59 -
Transitional BR (in GWR
Brown): W2780

Shop now



Siphon G - Dia. O.33 -
BR Carmine Red:
W2938W

Shop now



Siphon G - Dia. O.33 -
BR Maroon: W2942W

Shop now



Siphon G - Dia. O.59 -
BR Maroon: W2982

Shop now



Siphon G - Dia. O.33 -
BR Carmine Red:
W2977W

Shop now

Pre-Order Your Pannier



5700 Class -
5741 - GWR
Green

Shop now



5700 Class -
5754 - Great
Western Green

Shop now

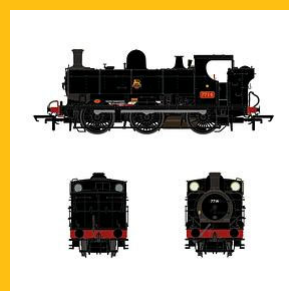

5700 Class -
7714 - Early
Emblem Black

Shop now

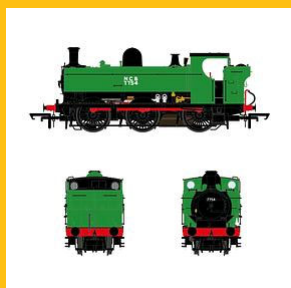

5700 Class -
7754 - NCB
Green

Shop now



5700 Class -
7755 -
Shirtbutton
Green

Shop now



6700 Class -
6743 - Great
Western Green

Shop now



8750 Class -
8763 - Early
Emblem Lined
Black

Shop now



8750 Class -
9681 - Late
Crest Black

Shop now



8750 Class -
9741 - British
Railways Green

Shop now

DCC Sound Fitted



5700 Class -
5741 - GWR
Green - DCC
Sound Fitted

Shop now



5700 Class -
5754 - Great
Western Green
- DCC Sound
Fitted

Shop now

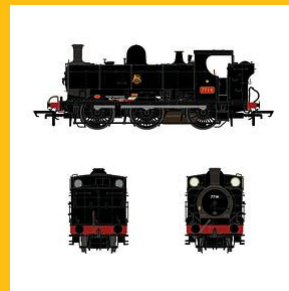

5700 Class -
7714 - Early
Emblem Black -
DCC Sound
Fitted

Shop now

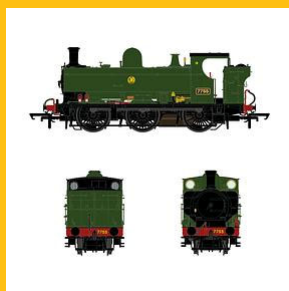
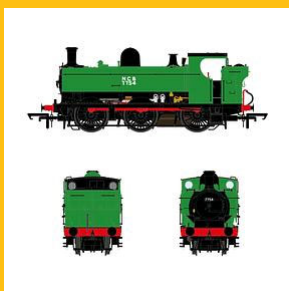

5700 Class -
7754 - NCB
Green - DCC
Sound Fitted

[Shop now](#)



5700 Class -
7755 -
Shirtbutton
Green - DCC
Sound Fitted

[Shop now](#)

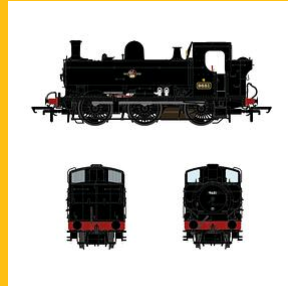

6700 Class -
6743 - Great
Western Green
- DCC Sound
Fitted

[Shop now](#)



8750 Class -
8763 - Early
Emblem Lined
Black - DCC
Sound Fitted

[Shop now](#)

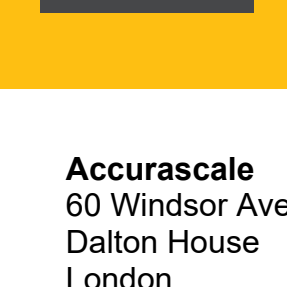

8750 Class -
9681 - Late
Crest Black -
DCC Sound
Fitted

[Shop now](#)



8750 Class -
9741 - British
Railways Green
- DCC Sound
Fitted

[Shop now](#)



Accurascale
60 Windsor Avenue
Dalton House
London
SW19 2RR
United Kingdom

[Unsubscribe](#)

© 2023 Accurascale

Da: Accurascale <support@accurascale.co.uk>
Inviato: mercoledì 29 novembre 2023 12:03
A: news_in@modellismoferroviario.it
Oggetto: Almost Gone - The Last of Our Original Class 37s

accurascale

Almost Gone - The Last of Our Original Class 37s



accurascale

Almost gone as soon as they arrived, we're down to our final stocks of our original 5 Class 37s, with just D6704 and 37001 remaining in very limited numbers.

Don't miss out on the 2023 Locomotive of The Year as voted by the readers of Hornby Magazine! Order yours below for the very

reasonable price of £169.99 DC/DCC ready and £259.99 DCC
Sound Fitted!



37001

Shop now



D6704

Shop now

**We also have a very limited supply of our Class 37/6
locomotives, should you prefer a more modern
era...**



37602

Shop now



37605

Shop now



37607

Shop now

Finescale Your Tractor With Our Drop In Scale Sized Wheelsets



Class 37 - EM / 18.2mm
Gauge Drop-In Wheel
Sets

[Shop now](#)



Class 37 - P4 / 18.83
mm Gauge Drop-In
Wheel Sets

[Shop now](#)

Accurascale
60 Windsor Avenue
Dalton House
London
SW19 2RR
United Kingdom

[Unsubscribe](#)

© 2023 Accurascale

Da: Accurascale <support@accurascale.co.uk>
Inviato: giovedì 30 novembre 2023 12:03
A: news_in@modellismoferroviario.it
Oggetto: Let's Go Bananas - SR Vans Production Complete

accurascale

Let's Go Bananas - SR Vans Production Complete



Great news! The production of our next all-new wagon project, our beautiful Southern Railway/BR Banana vans, is now complete and they have now left the factory!

We expect stock to arrive with us at year end, and following customs, QC checks and packing and Christmas holidays, that the models will begin to arrive with customers in early 2024.



Bringing our award winning approach on modern era wagons to pre-nationalisation prototypes, our Banana Vans are our first Southern Railway subject, and feature a wealth of variations, running numbers, individual markings and running numbers to help you form a prototypical length train.

A huge amount of separately applied parts, as well as brass bearings and a diecast chassis for excellent running characteristics elevate these wagons into the "Museum Quality" bracket and will set a new benchmark for Southern Railway wagons.

How much detail? As you can see from the unpainted sample below; all of it!

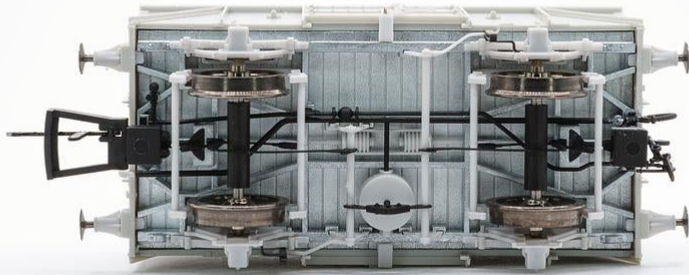

We have a limited supply of stock remaining, including our single pack "Accurascale Exclusive" of our BR Departmental Service Van too.

Each triple pack is priced at £84.95 each and our single pack exclusive is priced at £29.95, with 10% off when you buy any two packs or more, or even mix with our other wagon packs, along with free UK postage and packaging and 3% cash back on every purchase made direct.

Show via your local stockist, or below!

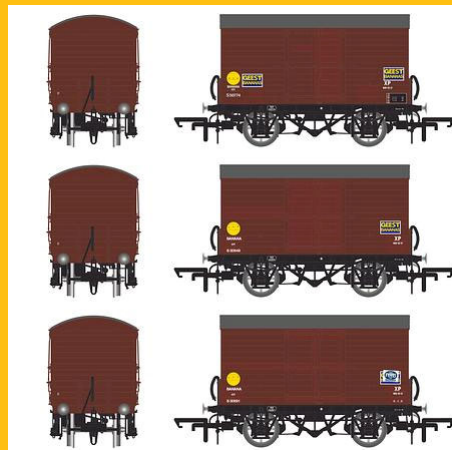

SR D1478 Van - British
Railways (1948-1961) -
Triple Pack

Shop now



SR D1478 Van - British
Railways (1961 onwards)
- Triple Pack

Shop now



SR D1479 Van - British
Railways (1948-1961) -
Triple Pack

Shop now

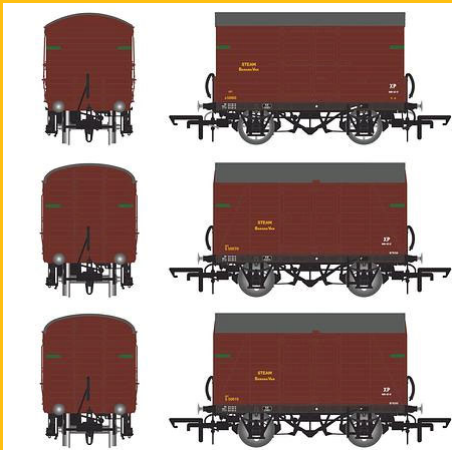

SR D1479 Van - British
Railways (1961 onwards)
- Triple Pack

Shop now



SR Mixed D1478/D1479
Van - Transitional British
Railways (1948-1950) -
Triple Pack

Shop now

SR Service Vehicle ex-
D1478 Van - British
Railways Departmental
Service Van (post-1971)
- Single Pack

Shop now

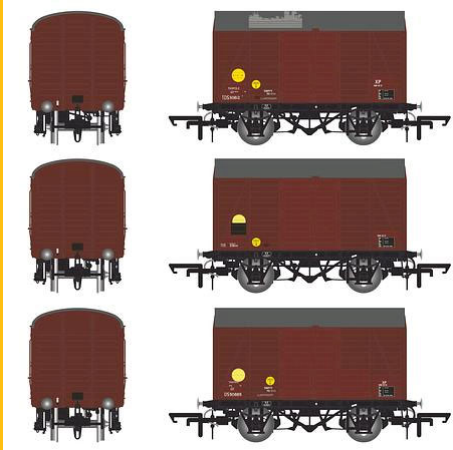

SR Tadpole ex-D1479 Van - British Railways Departmental - Triple Pack

Shop now

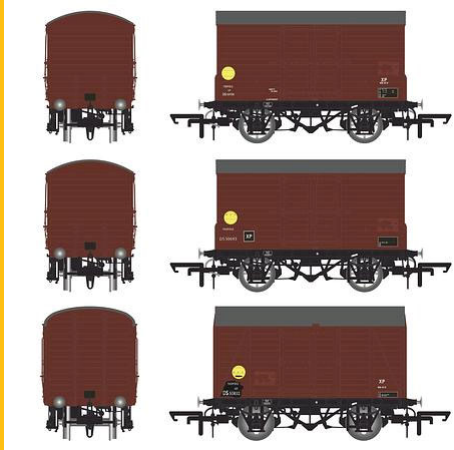

SR Tadpole Mixed ex-1478/1479 Van - British Railways Departmental - Triple Pack

Shop now

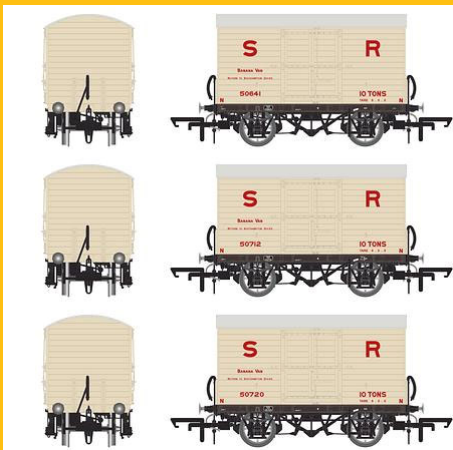

SR D1478 Van - Original SR Livery (pre-1936) - Triple Pack 1

Shop now

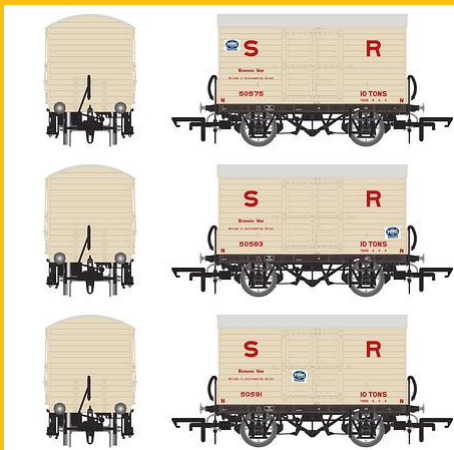

SR D1478 Van - Original SR Livery (pre-1936) - Triple Pack 2

Shop now

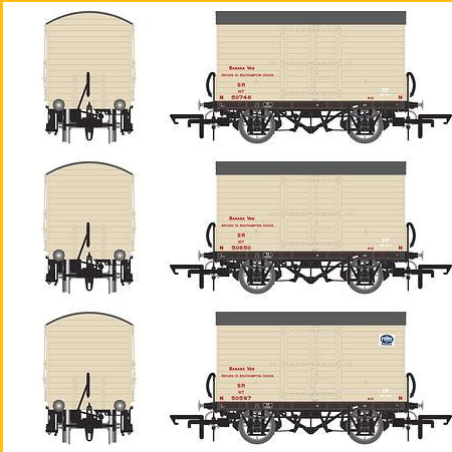

SR D1478 Van -
Modified SR Livery (1936
to March 1941) - Triple
Pack 1

[Shop now](#)

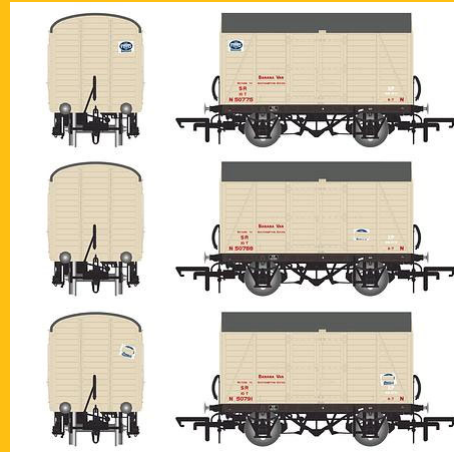

SR D1479 Van -
Modified SR Livery (1936
to March 1941) - Triple
Pack 2

[Shop now](#)

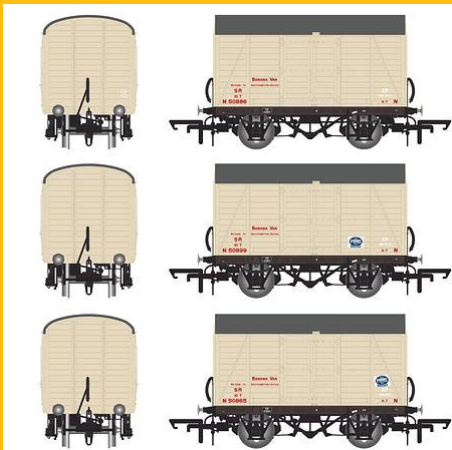

SR D1479 Van -
Modified SR Livery (1936
to March 1941) - Triple
Pack 3

[Shop now](#)

Accurascale
60 Windsor Avenue
Dalton House
London

SW19 2RR
United Kingdom

[Unsubscribe](#)

© 2023 Accurascale